

DISCUSSION PAPER SERIES

IZA DP No. 15450

**Estimating Intergenerational and
Assortative Processes in Extended
Family Data**

M. Dolores Collado
Ignacio Ortuño-Ortín
Jan Stuhler

JULY 2022

DISCUSSION PAPER SERIES

IZA DP No. 15450

Estimating Intergenerational and Assortative Processes in Extended Family Data

M. Dolores Collado

Universidad de Alicante

Ignacio Ortuño-Ortín

Universidad Carlos III de Madrid

Jan Stuhler

Universidad Carlos III de Madrid and IZA

JULY 2022

Any opinions expressed in this paper are those of the author(s) and not those of IZA. Research published in this series may include views on policy, but IZA takes no institutional policy positions. The IZA research network is committed to the IZA Guiding Principles of Research Integrity.

The IZA Institute of Labor Economics is an independent economic research institute that conducts research in labor economics and offers evidence-based policy advice on labor market issues. Supported by the Deutsche Post Foundation, IZA runs the world's largest network of economists, whose research aims to provide answers to the global labor market challenges of our time. Our key objective is to build bridges between academic research, policymakers and society.

IZA Discussion Papers often represent preliminary work and are circulated to encourage discussion. Citation of such a paper should account for its provisional character. A revised version may be available directly from the author.

ISSN: 2365-9793

IZA – Institute of Labor Economics

Schaumburg-Lippe-Straße 5–9
53113 Bonn, Germany

Phone: +49-228-3894-0
Email: publications@iza.org

www.iza.org

ABSTRACT

Estimating Intergenerational and Assortative Processes in Extended Family Data*

We quantify intergenerational and assortative processes by comparing different degrees of kinship within the same generation. This “horizontal” approach yields more, and more distant kinship moments than traditional methods, which allows us to account for the transmission of latent advantages in a detailed intergenerational model. Using Swedish registers, we find strong persistence in the latent determinants of status, and a striking degree of sorting – to explain the similarity of distant kins, assortative matching must be much stronger than previously thought. Latent genetic influences explain little of the variance in educational attainment, and sorting occurs primarily in non-genetic factors.

JEL Classification: J62

Keywords: intergenerational transmission, multigenerational transmission, assortative mating, extended kins

Corresponding author:

Jan Stuhler
Department of Economics
Universidad Carlos III de Madrid
Calle Madrid 126
28903 Getafe
Spain
E-mail: jstuhler@eco.uc3m.es

* Previous drafts of this paper circulated with the title “Kinship Correlations and Intergenerational Mobility”. We are grateful for helpful comments and suggestions from Adrian Adermon, Anders Björklund, Lorenzo Cappellari, Thomas Chaney, Gregory Clark, Alexia Führenkranz, Hans-Martin von Gaudecker, Andreas Gulyas, Marc Goni, Ricard Grèbol, Martin Hällsten, Ines Helm, Paul Hufe, Markus Jäntti, Mikael Lindahl, Matilde Machado, Martin Nybom, Andreas Peichl, Simon Rabaté, David Strömberg, seminar participants at the Université du Québec à Montréal, Nuffield College at Oxford University, the Joint Research Center of the European Union (Ispra), Rotterdam University, Stockholm University, the Selten Institute (Cologne), Cemfi (Madrid), University of Mannheim, CPB Netherlands, Università Cattolica in Milan, and the Institute of Economics, Polish Academy of Sciences in Warsaw. We thank the Swedish Institute for Social Research, Kristian Koerselman and the Instituto Cantabro de Estadística for data access. Financial support from the Ministerio de Ciencia, Innovación y Universidades (ECO2017-87069-P, ECO2017-87908-R and IJCI-2016-30011) and Comunidad de Madrid (EPU3M11 and H2019/HUM-5891) is gratefully acknowledged.

1 Introduction

The extent to which socioeconomic inequality is passed on across generations has gained renewed interest in recent years. Apart from the geographic variation in *parent-child* mobility (e.g. [Chetty et al., 2014](#)) and its relation with income inequality ([Corak, 2013](#)), researchers have begun to study *multigenerational* mobility across several generations. This evidence suggests that mobility is perhaps much lower than previously believed ([Clark 2014](#), [Lindahl et al. 2015](#), [Adermon, Lindahl and Palme 2021](#)), contradicting a common interpretation of conventional parent-child estimates – that the correlation between individuals in one generation and their ancestors decreases geometrically as we go back in time, so that after, say, three or four generations the link is already very weak.¹

Instead, recent studies suggest a high persistence of socioeconomic status. Using historical data from various countries and periods, [Clark \(2014\)](#) and [Clark et al. \(2015\)](#) show that the average status of *surnames* regresses at a rather slow rate. In data from Florence, earnings correlate across generations that are six centuries apart ([Barone and Mocetti, 2020](#)). Other studies link individuals across multiple generations to directly estimate multigenerational persistence ([Lindahl et al., 2015](#)), or to study the role of grandparents in the transmission process ([Engzell, Mood and Jonsson, 2019](#)). These individual-level studies likewise find high persistence, if not as high as studies on the surname level.

One problem with this “*vertical*” approach are the data requirements, as comparable socioeconomic information for more than two generations is difficult to obtain, and formal education or occupational rankings often vary little among older generations. Moreover, distant ancestors are rarely observed, so most studies use surnames as a proxy for actual ancestor links – triggering a lively debate on the informativeness of surname-level evidence. Studies based on direct links avoid this problem but only track the more immediate ancestors and yield few empirical moments, limiting our ability to distinguish between competing models of intergenerational transmission ([Cavalli-Sforza and Feldman, 1981](#)).

We therefore propose a new approach that does not require information on distant ancestors and instead uses “*horizontal*” information about individuals in the same or close generations. The underlying idea is simple. Say that we would like to assess the link

¹Such interpretations are based on the iteration of parent-child estimates, i.e. the assumption that the correlation between grandparent and grandchild outcomes is the square of the parent-child correlation, and thus small. As put by Becker and Tomes (1986), “*Almost all earnings advantages and disadvantages of ancestors are wiped out in three generations. Poverty would not [...] persist for several generations.*”

between grandparents and grandsons, but we do not have data for the former. If instead we have good data for cousins we can infer the strength of grandparents-grandsons links by comparing the cousins' outcomes – within the same data source and at approximately the same age and time. Thus, horizontal information can overcome the lack of comparable data across multiple generations.

Moreover, by chain-linking *affine* kinships we can identify very distant relatives, without recourse to historical sources. As *consanguine* (“blood”) kinships, *affine* (“in-law”) relations are a function of – and therefore informative about – intergenerational and assortative processes. But while the identification of distant consanguine kins requires the observation of distant ancestors (cousins via their shared grandparents, second-degree cousins via their great-grandparents, and so on), affine kins can be chain-linked from spousal and parental links *irrespective* of their degree of separation. In a first step, we identify a person's sibling. In a second step, we identify the sibling's spouse. Implemented once, these steps identify a sibling-in-law. Implemented twice, the sibling-in-law of the sibling-in-law, and so on.

This approach scales particularly well in large administrative data. Using Swedish registers that link multiple generations, we chain-link siblings and spouses up to five degrees of separations, resulting in 141 distinct kinship moments.² The horizontal approach yields therefore more comparable, more distant and *many more* moments than the traditional, vertical approach. That in turn opens the door for fitting a detailed model that allows for both direct and latent transmission mechanisms, for assortative matching in observable and latent advantages, and for asymmetries by gender. Our approach is particularly informative about the overall strength of transmission processes, but it is less informative about other important questions, such as the extent to which these processes vary over time or across groups.

In the first part of the paper, we study the *extent* to which advantages are passed on across generations. Our objective here is to quantify the contribution from intergenerational, sibling, and assortative processes, without trying to isolate any particular causal mechanism. We calibrate our model using educational attainment, but also consider income and height. We find that latent advantages are more strongly transmitted from parents to children than suggested by traditional parent-child correlations. Moreover, conditional on their latent

²To our knowledge, these are the most extensive sets of kinship moments that have been compiled so far. For example, [Behrman and Taubman \(1989\)](#) considered only eight kinship types. Some extended twin-family studies consider up to 80 types of relatives, but most involve some type of twins, have very low sample sizes, and capture similarity in behaviors such as smoking instead of socioeconomic outcomes.

advantages, the education of the parents has only a limited association with the education of their child (consistent with [Holmlund, Lindahl and Plug, 2011](#)).

Particularly striking is the high rate of assortative matching that our data imply. The kinship correlations in educational attainment decay only slowly across siblings-in-law, by around one quarter for each additional spousal link. To explain such slow decay, spouses must share advantages to a far greater extent than indicated by conventional measures of sorting, such as the spousal correlation in years of schooling. Likewise, siblings must be more similar in those factors that determine the socioeconomic success of their descendants than they are in observables: while the sibling correlation in years of schooling is around 0.4, the implied correlation in their latent advantages is nearly twice as large.

These results contribute to different strands of the literature on inequality and intergenerational mobility. First, they provide a new perspective on traditional measures of the importance of family background based on *close* relatives, such as *intergenerational correlations*, *sibling correlations* or measures of *equality of opportunity*. These measures capture different aspects and point to different rates of mobility ([Björklund and Jäntti, 2019](#)). We propose a more comprehensive way of capturing background effects based on the comparison of many kinship types, which integrates intergenerational and sibling correlations and suggests that both understate the importance of family background.

Second, we corroborate recent findings based on *multigenerational* correlations, which suggest that inequality is more persistent than previously thought (e.g., [Clark 2014](#), [Lindahl et al. 2015](#), [Braun and Stuhler 2018](#), [Adermon, Lindahl and Waldenström 2018](#), and [Colagrossi, d’Hombres and Schnepf 2019](#)). Importantly, our approach is very different: it does not require any information on distant ancestors, or the use of name-based estimators, whose validity have been contested.³ High multigenerational persistence is consistent with the similarity between horizontal kins that we document here, although we find less extreme persistence than some name-based studies.⁴

Third, our study provides a novel perspective on the strength of assortative matching, which is an important determinant of intergenerational persistence ([Ermisch, Francesconi and Siedler, 2006](#)) and inequality ([Fernández and Rogerson, 2001](#)). The literature fo-

³See [Chetty et al. \(2014\)](#), [Güell, Rodríguez Mora and Solon \(2018\)](#) and [Solon \(2018\)](#), among others.

⁴It is also consistent with recent studies of relatives in the horizontal dimension. [Hällsten \(2014\)](#) and [Hällsten and Kolk \(2020\)](#) estimate the correlations between distant cousins in Sweden. [Adermon, Lindahl and Palme \(2021\)](#) consider “dynastic human capital” based on a broad set of kinships, including horizontal kins. Such evidence opens the door for the identification of detailed transmission models, as we show here.

cuses on educational sorting, and its potential contribution to rising income inequality in many countries. Our evidence, however, suggest that the extent of sorting in *observable* characteristics such as education greatly understates the sorting in *latent* advantages.

Our approach can be also informative about causal mechanisms, to the extent that different mechanisms have distinct implications for the correlation pattern between kins. Many papers estimate the relative importance of nature and nurture by studying different types of twins or adoptees (Behrman and Taubman 1989, Björklund, Jäntti and Solon 2005). In contrast, our baseline model decomposes the family background into *transferrable* and *non-transferrable* rather than into genetic and environmental components. The obvious disadvantage is that we remain largely agnostic about what mechanisms the latent factor of our model represents. The principal advantage, however, is that it captures inequalities more comprehensively, as it also captures non-genetic advantages.⁵

In the second part of the paper, we consider different genetic models to study whether genetic factors could be one important component of these latent advantages. We first show that the standard genetic model with phenotypic assortment as used in quantitative genetics (Crow and Felsenstein, 1968) or assortment on the genotype (Clark, 2021) cannot fit the kinship correlations in educational attainment. Our data are therefore inconsistent with a purely genetic interpretation. The observability of a wide range of kinship moments is critical for this conclusion, as the genetic model *can* fit a small number of close kins; its inadequacy becomes apparent only when challenged to fit a more extensive set of kinships. We then fit an extended model with both genetic and non-genetic latent components. We find that the genetic pathways of our model explain a much smaller share of the variance in years of schooling than non-genetic advantages, and that genetic and non-genetic advantages are transmitted at a similar rate. The former result is consistent with recent evidence from genome-wide association studies (Okbay and et al. 2016, Lee and et al. 2018, Papageorge and Thom 2018). The latter result suggests that genetic and non-genetic factors are difficult to distinguish based on ancestor correlations alone.⁶ We can distinguish them here because their pattern deviates more strongly for spouses and in-laws in horizontal moments.

⁵We also do not have to deal with the complicated problem of the relationship between genes and environment. By definition, the non-transferable component captures all the effects that siblings share and that are not correlated with the transferable components.

⁶This difficulty has been recognized for a long time in the literature on population genetics. For example, Cavalli-Sforza and Feldman (1981) noticed that "*any variable (other than genotype) that is vertically transmitted and not measured will very frequently be indistinguishable from genotype*" (pp. 287-288).

2 Theory

Our baseline model deviates in three important aspects from the prior literature. First, we allow for *direct* (observable) and *latent* (unobservable) transmission mechanisms. Second, we allow for assortative mating along two distinct dimensions, and account for both parents explicitly. Third, we consider how the strength of the transmission mechanisms vary with the gender of the child and the parent. In Section 5.2 we extend this model further.

2.1 General Model

Suppose that y is a socioeconomic outcome of interest, such as income or education. We henceforth identify y with years of schooling, the baseline outcome in our empirical exercise. We study the link of such variable y between individuals and their ancestors. Specifically, assume that the outcome y for an individual from generation t is given by

$$y_t^k = \beta^k \tilde{y}_{t-1}^k + z_t^k + x_t^k + u_t^k \quad (1)$$

where the superscript k stands for male ($k = m$) and female ($k = f$). The first component \tilde{y}_{t-1}^k is the weighted average socioeconomic status of parents,

$$\tilde{y}_{t-1}^k = \alpha_y^k y_{t-1}^m + (1 - \alpha_y^k) y_{t-1}^f,$$

where $\alpha_y^k \in [0, 1]$. The parameters β^k and α_y^k capture the *direct* transmission of parental on child outcomes, which we allow to be distinct for each parent-child gender combination.

The *latent factor* z_t^k captures the unobservable determinants of child outcomes that are passed from parents to children (see Section 2.2). As the observable determinant, it depends on the weighted average latent status of the parents \tilde{z}_{t-1}^k ,

$$z_t^k = \gamma^k \tilde{z}_{t-1}^k + e_t^k + v_t^k, \quad (2)$$

where

$$\tilde{z}_{t-1}^k = \alpha_z^k z_{t-1}^m + (1 - \alpha_z^k) z_{t-1}^f \quad (3)$$

and $\alpha_z^k \in [0, 1]$. The parameters γ^k and α_z^k capture the strength of indirect transmission channels, i.e. factors that impact observable outcomes but that are not directly observed

themselves. We again allow for distinct pattern across all four parent-child gender combinations. Equations (2) and (3) do not necessarily map into one particular (e.g., genetic or behavioral) mechanism, but may represent a great number of underlying mechanisms. Such “reduced-form” representations have been common in theoretical work (e.g., [Becker and Tomes, 1986](#)), and we discuss its interpretation in Section 2.5.

The model includes four types of shocks: a white-noise error u_t^k , a shared *sibling component* x_t^k (shared by siblings of the same gender, correlated across siblings of different gender, and uncorrelated with the other variables, in particular z_t^k and y_{t-1}^k), a white-noise error term v_t^k in the latent factor, and the latent sibling component e_t^k (shared by same-gender siblings and potentially correlated for mixed genders).⁷ Allowing flexibly for shared influences among siblings that are orthogonal to the parental influences z_{t-1}^k and y_{t-1}^k allows us to extend our analysis in the horizontal dimension (see Section 2.4).⁸

We allow for assortative mating both in the observable and latent socioeconomic status. In particular, we consider the linear projections of z_{t-1}^f and y_{t-1}^f on z_{t-1}^m and y_{t-1}^m ,

$$z_{t-1}^f = r_{zz}^m z_{t-1}^m + r_{zy}^m y_{t-1}^m + w_{t-1}^m \quad (4)$$

$$y_{t-1}^f = r_{yz}^m z_{t-1}^m + r_{yy}^m y_{t-1}^m + \varepsilon_{t-1}^m \quad (5)$$

where w_{t-1}^m and ε_{t-1}^m might be correlated but are uncorrelated with z_{t-1}^m and y_{t-1}^m . In Online Appendix A, we show that the coefficients r_{sd}^m ($s, d = y, z$) are functions of the correlations and standard deviations $\rho_{z^m y^m}, \rho_{z^m z^f}, \rho_{z^m y^f}, \rho_{y^m z^f}, \rho_{y^m y^f}, \sigma_{z^m}, \sigma_{z^f}, \sigma_{y^m}$ and σ_{y^f} . We also provide the corresponding coefficients from the linear projections of z_{t-1}^m and y_{t-1}^m on z_{t-1}^f and y_{t-1}^f , and show that $\rho_{z^m y^m}$ and $\rho_{z^f y^f}$ are functions of the other parameters through two steady-state equations. We then use these linear projections to derive each kinship correlation as a function of the model parameters.⁹

⁷Our structure is therefore less restrictive than other approaches in the literature. For example, we do not assume that sibling differences in education are exogenous, as in twin fixed effect estimates of the effect of parent on child schooling ([Holmlund, Lindahl and Plug, 2011](#)). The outcome difference between siblings A and B in our model equals $y^A - y^B = u^A - u^B + v^A - v^B$ and reflects chance *and* systematic differences in latent characteristics (e.g., in abilities).

⁸Possible sources of the sibling component in the latent factor are random school, peer and neighborhood effects; but they could also reflect direct effects from the parent, over and above of what can be explained by their y and z . For example, the parents may by chance read a parenting book on how to better raise their children (all their children, hence the systematic sibling component).

⁹In Section K of a document titled “Additional Derivations” (available on the authors’ webpages or upon request), we show that it is not generally possible to reduce this two-parent model to a one-parent model without imposing restrictions on either the assortative or the intergenerational process.

2.2 Direct and Latent Transmission Channels

The theoretical literature has long recognized that part of the transmission process from parents to children may be inherently unobservable. The latent variable in our model is close in spirit to [Becker and Tomes \(1979\)](#), who assume that a person’s “*endowment*” represent a great variety of cultural and genetic attributes. The distinction between direct (via observables) and indirect (via latent variables) transmission mechanisms has also been influential in a literature on cultural transmission in population genetics (e.g., [Rice, Cloninger and Reich 1978](#), [Cavalli-Sforza and Feldman 1981](#)).

Such latent pathways have seen renewed interest due to recent work on *multigenerational* transmission, which documents that inequalities appear more persistent than suggested by traditional parent-child correlations. Studies based on historical records indicate that inequalities *between surnames* persist over very long periods ([Clark 2014](#), [Barone and Mocetti 2020](#)). Estimates from direct family links across multiple generations also point to high persistence (e.g., [Lindahl et al. 2015](#), [Dribe and Helgertz 2016](#), [Braun and Stuhler 2018](#), [Long and Ferrie 2018](#), [Neidhöfer and Stockhausen 2019](#), [Colagrossi, d’Hombres and Schnepf 2019](#), [Hällsten and Kolk 2020](#)).

The existence of latent pathways would explain these findings ([Clark 2014](#), [Stuhler 2012](#)). If the latent variable is comparatively persistent across generations ($\gamma^k > \beta^k$), but explains only part of the inequality in socioeconomic outcomes ($\sigma_{z^k}^2 < \sigma_{y^k}^2$), then the parent-child correlation may greatly understate the actual transmission of advantages or its variation across groups, areas, and time. Intuitively, the observable socioeconomic status is only an imperfect proxy for socioeconomic prospects, a type of “measurement error” that attenuates traditional measures of intergenerational transmission.

Such latent mechanisms may not be the only reason why intergenerational correlations understate the transmission of advantages. An alternative hypothesis that might generate similar implications is that the transmission process varies systematically across families.¹⁰

We do not take a strong stance on what is the true transmission model. Instead, our model can be interpreted as a simplified reduced form of an underlying structural model; an important question is whether it fits the data.

¹⁰Indeed, [Bingley and Cappellari \(2019\)](#) and [Colagrossi et al. \(2020\)](#) show that such heterogeneity would affect the relative size of intergenerational and sibling correlations. High multigenerational persistence could also be generated by a multi-skill model, in which different types of skills are transmitted at different rates (“multiplicity”, [Stuhler, 2012](#)) or non-Markovian models that allow for “grandparent effects” ([Mare, 2011](#), [Anderson, Sheppard and Monden 2018](#), [Engzell, Mood and Jonsson 2019](#)).

2.3 Assortative Mating

Most intergenerational studies consider a simplified one-parent family structure, in which the assortative process enters only implicitly. But it is fundamental to understand the recent multigenerational evidence, as high rates of persistence across generations requires strong assortative mating (Clark and Diaz-Vidal 2015, Braun and Stuhler 2018). Spousal correlations in socioeconomic outcomes are typically between 0.4 and 0.6 (e.g., Fernández and Rogerson 2001, Ermisch, Francesconi and Siedler 2006). But as we show below, there needs to be far greater sorting between spouses to explain the similarity between distant kins that we document in this paper. We explain this discrepancy by allowing spouses to be similar not only in observable but also in *unobservable* characteristics. Intuitively, their observed similarity in socioeconomic outcomes (y_{t-1}^k) may not reflect the effective degree of sorting in other characteristics that determine the prospects of their offspring (z_{t-1}^k in our model). The pattern of dependence between distant kins can therefore be informative about formerly unknown aspects of the assortative process.

2.4 Horizontal Kinship

Our model is too complex to be identified from inter- or multigenerational moments alone, which has been the traditional approach. Thus, we make use of “*horizontal*” moments, considering relatives in the same generation. Because siblings share influences over and above parental influence, we allow for shared sibling components in both the observable outcome y and the latent advantage z . By modeling both assortative and sibling processes, we can also include siblings-in-law in our analysis.

Compared to multigenerational studies, we do not require information on distant ancestors, and can measure socioeconomic outcomes at a similar age and time. Most importantly, the horizontal approach yields a much greater set of empirical moments.¹¹ We distinguish several dozen *consanguine* (“blood”) kinships, but extend our analysis also to *affine* (“in-law”) kinships such as siblings-in-law. While they may not descend from a common ancestor, affine kins have similar informational value as consanguine kins – both are a function of, and therefore informative about, intergenerational and assortative processes (see

¹¹The advantage of studying distant relatives within the same generation is also emphasized by Hällsten (2014), Adermon, Lindahl and Palme (2021) [ALP] and Hällsten and Kolk (2020). In comparison to these studies, we chain-link distant *in-laws* and use the empirical moments to identify an explicit transmission model. In Sections 3.2 and 4.3 we compare our methodology and findings to ALP.

Figure 1: The Chain-linking of Siblings-in-law

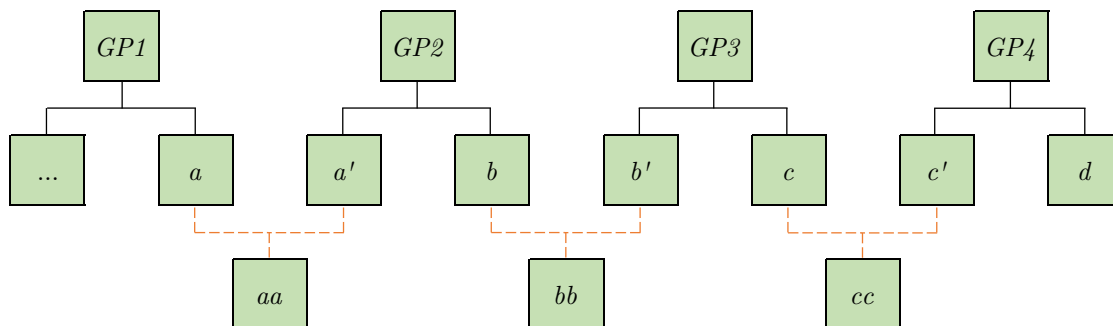

Notes: Hypothetical family trees across child, parent, and grandparent (GP) generation. Consanguine (affine) relationships in black solid lines (orange dashed lines).

Online Appendix A).¹² Moreover, correlations are non-directional, so alternating between vertical and horizontal links is conceptually similar to the linking of distant ancestors – but more feasible.

The key advantage of affine as compared to consanguine relations is that they can be traced over exceptionally long “distances”. Figure 1 illustrates the logic in hypothetical family trees across a child, parent, and grandparent (GP) generation. The identification of distant consanguine kins necessitates the observation of distant ancestors. For example, the identification of cousins (e.g., $aa-bb$) requires the observation of their shared grandparents (GP2), while the identification of second-degree cousins would require observation of their great-grandparents, and so on. As a consequence, distant family links are rarely directly observed, and evidence on mobility in the very long run is instead based on their probabilistic approximation via *surnames* (e.g., Clark 2014, Barone and Mocetti, 2020).

In contrast, affine relationships are defined only via spousal and parental links – irrespective of their degree of separation. In a first step, we identify a person’s spouse (e.g., $a-a'$) via their shared descendant (aa). In a second step, we identify the spouse’s sibling (b) via their parents (GP2). Implemented once, these steps identify a pair of *siblings-in-law* ($a-b$). Implemented twice, we identify the *sibling-in-law of the sibling-in-law* ($a-c$), and so on. In population-wide data one can reiterate these linkages – and therefore the number of empirical moments – ad infinitum. In this study, we consider all possible kinship types and gender combinations up to fifth-order affinity relations – resulting in 141 distinct kinship moments. Chain-linking horizontal kins yields therefore many more, and more distant moments than a vertical perspective.

¹²The informational value of non-genetic relatives has been also exploited in population genetics. For example, it has led to much lower estimates of the heritability of human longevity (Ruby et al., 2018).

2.5 Interpretation

Our model can be interpreted as a reduced-form representation of the causal effect of family background, decomposed into its intergenerational and assortative, observable and latent pathways. Most existing work focuses on simpler descriptive measures, such as intergenerational or sibling correlations, or specific mechanisms, such as the causal effect of parent on child education (see Björklund and Salvanes, 2011). In comparison, our approach has distinct advantages and disadvantages. The obvious disadvantage is that we remain largely agnostic about the precise mechanisms that the pathways of our model represent.¹³ The principal advantage, however, is that it provides a more comprehensive account of intergenerational transmission.¹⁴ For example, our latent factor z_t^k is a more comprehensive object than the “genotype” considered in behavioral genetics, as it also captures non-genetic advantages that affect the next generation. Similar to Ruby et al. (2018), we quantify the “*transferable variance*” of an outcome that includes genetic heritability but also the variance due to inherited socio-cultural factors, as well as the covariance between the two. While our primary objectives are statistical, we can test if specific causal pathways such as geographic (im)mobility (Section 4.9) or genetic transmission (Section 5) could explain our results.

3 Data and Calibration

3.1 Swedish Multigenerational Registers

Our sample is based on a random 35% draw of the Swedish population born between 1932 and 1967, as well as their biological parents, siblings and children (see Björklund, Jäntti and Lindquist 2009, Statistics Sweden 2016). We define kinship based on biological links, with a man and woman considered to be spouses if they have a child together, irrespectively of whether they married or cohabitate.¹⁵ We match individual characteristics from bi-

¹³We also remain agnostic on whether the proxy y_t^k or the latent status z_t^k represent a better measure of an individual’s actual socioeconomic status. A recent strand of the literature provides evidence on this question by aggregating multiple proxies for socioeconomic status, and is complementary to our approach (Vosters and Nybom 2017, Blundell and Risa 2018, Adermon, Lindahl and Palme, 2021).

¹⁴Our approach shares aspects with the literature on siblings correlations, which are a more comprehensive measure of family influences than intergenerational correlations (Jäntti and Jenkins, 2014). However, sibling correlations still capture only advantages that are directly reflected in child outcomes, while our approach captures also advantages that are *not* visible but that affects their prospects.

¹⁵Individuals might feature in more than one family if they have children with different partners. Dropping those observations would have only a negligible effect on our estimates as their share is small (6%).

Table 1: Descriptive Statistics in Swedish Registers

Variable	Generation	Cohorts	Observations	Men		Women	
				Mean	Std. Dev.	Mean	Std. Dev.
Education	Child	1966-76	1,026,084	12.35	2.16	12.81	2.12
	Parent	1920-62	2,502,869	10.70	3.01	10.60	2.88
Income	Child	1958-68	1,062,847	12.30	0.55	11.97	0.50
	Parent	1923-53	1,811,895	12.37	0.52	11.82	0.80
Height	Child	1974-80	269,475	179.73	6.55		
	Parent	1951-66	378,686	178.99	6.37		

Notes: Education is measured as years of education. Income is measured as the logarithm of ten-year average pre-tax incomes at age 30-39 for children and age 45-54 for parents. Height in cm is observed for men only.

decennial censuses (starting from 1960), official registers, and military enlistment tests. Our baseline outcome is *educational attainment*, but we also consider *income* and *body height*. Table 1 shows basic descriptive statistics.

Education. Educational registers were compiled in 1970, 1990, and about every third year thereafter up to 2007. We consider the highest schooling level recorded across these years, and translate it into years of education, with seven years for the old compulsory school being the minimum, and 20 years for a doctoral degree the maximum. As the data are collected from official registers, they are not subject to non-response problems.¹⁶ We measure education up to cohorts born in the mid-1970s, after which the information becomes less reliable at the top of the attainment distribution.

Income. We observe long income series for the years 1968-2007. We consider total (pre-tax) income, which is the sum of an individual’s labor (and labor-related) earnings, early-age pensions, and net income from business and capital realizations, and express all incomes in 2005 prices. To reduce attenuation and life-cycle biases (e.g., [Nyblom and Stuhler, 2017](#)), we measure ten-year average incomes at age 30-39 for children and age 45-54 for parents, considering child cohorts born in 1958-68. To probe the influence of measurement error, we also estimated our model based on shorter income spans.

Height. We observe height from military enlistment data, which was universal for all men at the time. Because we observe height only for cohorts born between 1951 and 1980, we can consider father-child and other vertical correlations only for fathers who were sufficiently young at the birth of their child (we impose a minimum age of 18 years). This

¹⁶In the 1970 Census, we impute 7 years for the (old) primary school, 9 years for (new) compulsory schooling, 9 years for post-primary school (realskola), 11 years for short high school, 12 years for long high school, 14 or 16 years for short or long university programs, and 20 years for a PhD. Schooling levels are recorded in more details in later registers. Educational information in 1970 is missing for those born before 1911 and those who died or emigrated before 1970, but the share of affected observations is small.

sample restriction is less problematic for height than for other outcomes, as the vertical correlations vary less with parental age at birth.

Standardizations. Kins can be born in different cohorts and their outcomes being measured in different years, so we de-mean all outcomes by birth cohort and gender. To reduce the influence of outliers, income averages are censored at the 1st and 99th percentiles (again by birth cohort and gender). These standardizations are performed in the full sample, before selecting specific kinship pairs. In a robustness test we standardized also the variance of each outcome (i.e., z-scores), which had only negligible effects on our results.

Cohort Selection. Multiple sources of selection need to be taken into account, separately for each outcome and kinship type (see Online Appendix F). We first select cohorts for which the *outcome* is reliably observed, as described above. We then assess which *kinship types* can be reliably identified within those cohorts. For example, the identification of siblings requires observation of their parents, while for the identification of cousins we need to observe grandparents, and so on. While the match rates of parents and grandparents are very high, the match rate of great-grandparents is not. We therefore abstain from kinship types that depend on the identification of great-grandparents, and consider only outcomes for the two younger generations. To avoid selectivity with respect to the *age difference* between kins, we use a broad range of cohorts to measure horizontal moments. As an exception the range is narrow for cousins, as they have to be identified via their grandparents. This reduces the age difference and introduces an upward bias in our sample correlations for cousins (Section 4.6 and Online Appendix F.3).

Linearity. As we summarize the similarity between kins using linear correlations, we might be concerned whether these linear measures provide a good approximation of the actual relationship in the data. We thus studied the conditional expectation function between different types of relatives using binned scatter plots and similar diagnostics. The expectation of child schooling conditional on parent schooling is approximately linear, but slightly shallower for low levels of schooling. The conditional expectation is very linear for distant kinship types. We conclude that linear correlations provide a reasonably good summary of the statistical associations observed in the data.

Distant chains and duplicate entries. The chains that link distant in-laws may contain duplicate entries. For example, an individual may be his own second-degree brother-in-law if two families are connected via more than one spousal link. In principle, duplicate entries

are a reflection of the assortative process, and should be retained. For example, inequality might be more persistent if in-law relations “circle” within closed groups defined by geography, ethnicity, or other characteristics. However, as we observe only a random subset of the Swedish population, duplicate entries occur at a higher rate. We therefore drop all chains with duplicate entries, which slightly decreases the more distant correlations.¹⁷

Family size. Given our intergenerational focus, we restrict our sample to individuals who have at least one child. However, we need to decide how to weight large compared to small families, because fertility might vary with socioeconomic status (it varies little in our sample) and kinship correlations might vary with family size (for example, spousal correlations are slightly larger in large families).¹⁸ While this choice arises in all intergenerational studies, it could be more important here as the number of kinship pairs per family varies more strongly for distant than for close kins (e.g., it varies more for cousins than siblings). We therefore considered three different sets of weights, ranging from uniform to proportional to the number of kinship pairs per family (see [Donner, 1986](#)). However, the sample correlations are not very sensitive to this choice.¹⁹ We picked an intermediate scheme, weighting each family by the square root of their number of distinct pairs.

3.2 Estimation and Calibration

Since we can directly estimate σ_{ym} and σ_{yf} from the data, we have 20 unknown parameters,

$$v = \left\{ \beta^m, \gamma^m, \sigma_{zm}, \sigma_{xm}, \beta^f, \gamma^f, \sigma_{zf}, \sigma_{xf}, \rho_{xmxf}, \rho_{zmzf}, \rho_{ymyf}, \rho_{zmyf}, \rho_{ymzf}, \alpha_y^m, \alpha_z^m, \alpha_y^f, \alpha_z^f, \sigma_{em}, \sigma_{ef}, \rho_{emef} \right\},$$

and therefore we need at least 20 correlations between relatives of different kinship.²⁰ We calibrate the parameters by solving the following minimization problem,

$$\text{Min}_{v \in F} \sum_{i \in C} p_i (\rho_i - \bar{\rho}_i)^2, \quad (6)$$

¹⁷For example, it decreases the third degree sibling-in-law correlations by around 5%.

¹⁸A family or “cluster” is defined by the most recent common ancestor for biological kins, or by the linking spouse for in-laws. We do not study heterogeneity by family arrangement (e.g., divorce or cohabitation).

¹⁹The correlation between the set of sample moments estimated under the two most extreme weighting schemes is greater than 0.99.

²⁰In [Online Appendix B.2](#), we provide explicit identification results for a restricted version of our baseline model. The restrictions hold approximately in our application. We have also performed simulation exercises to verify that the parameters of the baseline model can be recovered from the set of kinship correlations used in our empirical application.

where v is the set of parameters, ρ_i are the theoretical correlations (which are a function of v , as derived in the Online Appendix A), \bar{p}_i the empirical correlations, p_i the weight given to each term, F is the set of feasible values for the unknown parameters, and C denotes the set of correlations.²¹ In most cases we give the same weight to all correlations so that $p_i = 1$ for all $i \in C$, but the results are very similar if we weight each moment by the number of families used to calculate the sample correlation.

Our approach relates conceptually to an instrumental variable strategy in which a more distant relative’s outcome is used as an instrument for the parent’s outcome in the parent-child regression. Lindahl et al. (2015), Braun and Stuhler (2018), Neidhöfer and Stockhausen (2019) and Colagrossi, d’Hombres and Schnepf (2019) instrument parent with grandparent outcomes, while Adermon, Lindahl and Palme (2021) instead consider extended family members in the parent generation (such as aunts and uncles, their spouses, or parents’ cousins). This instrumental variable estimator corresponds to the ratio between two kinship moments, one more distant than the other (e.g, the ratio between the grandparent-child and parent-child covariances).

While we also compare close and distant kins, our approach differs in two ways from the instrumental variable approach. First, identification is indirect rather than direct. The parameters of a simple intergenerational model can be directly mapped into the IV estimator, and we show such direct identification for a restricted version of our model in Online Appendix B.2.²² However, this direct mapping between the IV estimator and model parameters breaks down in richer models, and our baseline model cannot be solved analytically. In such more general models, the IV estimator maps into an amalgam of multiple model parameters, and is more difficult to interpret.²³

²¹We cannot estimate the parameters by GMM as in Abowd and Card (1989) because the units of analysis, families, are not well defined. Moreover, most individuals will belong to different families and therefore the sample units will not be independent (see Appendix E). We have used Mathematica 11.3 to solve the minimization problem (code available upon request). We have used the Simulated Annealing algorithm, which is a stochastic function minimizer. We have used a minimum of 10,000 random starting points from the set of feasible values F . In most exercises, and in particular in our benchmark case, we reach the same minimum for most of the starting points, so that we are confident to have found a global minimum. We also tried other algorithms for constrained global optimization (Nelder-Mead, Differential Evolution and Random Search) and never found a different global minimum.

²²For example, in a restricted model with no direct effect ($\beta = 0$) and assortative mating only in the latent factor z , the assortative mating parameter can be identified from the covariance ratio of the spouse of the sibling-in-law to the sibling-in-law (or the ratio of the uncle in law to the uncle), while the intergenerational process can be identified from the covariance ratio of the spouse of the uncle to the sibling-in-law.

²³Adermon, Lindahl and Palme (2021) provide conditions under which the IV estimator can be interpreted as an upper bound of the total influence of members of the extended family. Similarly, we can use our transmission model to derive conditions under which the IV estimator maps into a parameter of interest (see Online Appendix B.2).

Table 2: List of Kinship Types

group	name	class	# moments
$a-a'$	Spouses	consanguine, horizontal	1
$a'-b$	Siblings	consanguine, horizontal	3
$aa-bb$	Cousins	consanguine, horizontal	10
$aa-a$	Parent-child	consanguine, vertical	4
$aa-b$	Uncle/aunt-child	consanguine, horizontal & vertical	8
$a-b$	Siblings-in-law (degree 1)	affine, horizontal	4
$a-b'$	Spouse of sib-in-law (degree 1)	affine, horizontal	3
$a'-c$	Sibling of sib-in-law (degree 1)	affine, horizontal	4
$aa-b'$	Child-sibling in law (degree 1)	affine, horizontal & vertical	8
$a-c$	Siblings-in-law (degree 2)	affine, horizontal	8
...
$a-d$	Siblings-in-law (degree 3)	affine, horizontal	16
...

Notes: The number of distinct moments within each kinship type is determined by the potential set of gender combinations (such as brother-brother, sister-sister, and brother-sister). See Figure 1 for definition of kinship types.

Second, we consider many kinship moments simultaneously (105 moments in our baseline calibration) while the IV approach is based on only two moments. Apart from a gain in efficiency, this allows us to assess the quality of our predictions. While the IV approach can be used to estimate a simple intergenerational model, it is not informative about whether that model provides reasonable predictions that fit the data. In contrast, we will test whether our model replicates the transmission pattern across many different types of kins, including those that have not been used to fit the model. We believe our intergenerational model is the first to fit a wide array of consanguine and affine kinships.

4 Estimation Results

In this section, we report our baseline results, considering years of schooling as our dependent variable. Table 2 provides a partial list of the kinship types, as well as the number of moments within each group. Considering siblings-in-law up to five degrees of separation, we observe 141 distinct moments. The formulas for each of them as a function of the model parameters are presented in Online Appendix A.

4.1 Sample Moments

Table 3 reports the sample correlation in years of schooling for each kinship moment. The moments are sorted by kinship type, from closely related to more distant kins. The first

columns report the number of pairs and sample correlations. The sample correlations in years of schooling span between one-half for close kins, such as spouses or brothers, to only a fraction of that for the most distant kinship types. Owing to the large number of observations, all correlations are precisely estimated.²⁴ As far as they overlap, they appear consistent with estimates from the previous literature.²⁵

4.2 Calibrated Moments

In our baseline calibration, we include siblings-in-law up to three degrees of separation but do not include cousins or higher-order in-laws (see Section 4.6). With these restrictions, our baseline calibration is based on 105 distinct kinships, grouped into fourteen different kinship types. We calibrate the model as described in Section 3, and report the predicted moments and their percentage deviation to the observed moments in the final columns of Table 3. Moments that were not included in the calibration are printed in italics.

Figure 2 illustrates the in-sample fit graphically, by plotting sample moments (orange) and predicted moments from the calibrated model (blue dots). The model explains the data well, for both vertical and horizontal moments, and for both consanguine (“blood”) and affine (“in-law”) kinships. In percentage terms, the out-of-sample fit is worst for cousins and extremely distant in-laws. We return to those issues below. The mean absolute error across all moments used in the calibration (across all moments) is 2.5% (7.2%). These results suggest that it is possible to fit the pattern of inequality across very different kinship types, using a parsimonious model with a limited set of transmission pathways.

4.3 Intergenerational Transmission

Table 4 summarizes our baseline findings. Panel A reports the calibrated parameters for the intergeneration or “vertical” components of our model as well as the implied autocorrelation to parents or paternal ancestors. As motivated in Section 2.2, we distinguish between the *direct* transmission of advantages in our outcome of interest (i.e., educational attainment), and the transmission of *latent* advantages that contribute to the socioeconomic

²⁴For the moment with the smallest number of observations (female cousins) the standard error is 0.0036.

²⁵For example, Björklund, Jäntti and Lindquist (2009) report that the correlation in years of schooling between brothers in Sweden is slightly below 0.5 (cf. 0.43 in our sample). Hällsten (2014) estimates that the corresponding correlation for cousins is about 0.15, which fits our model predictions but is below our own sample correlation. We return to this contrast below.

Table 3: Sample and Predicted Moments in Swedish Registers

Kinship		Data		Calibration		Kinship		Data		Calibration	
group	# name	# pairs	sample ρ	pred. ρ	% error	group	# name	# pairs	sample ρ	pred. ρ	% error
I	1 Spouses	413,062	0.491	0.489	-0.3						
II	2 Brothers	387,028	0.432	0.431	-0.3	XII	72 MF-FM-MF	299,602	0.138	0.135	-2.2
<i>a'-b</i>	3 Sisters	431,698	0.416	0.416	0.2		73 FM-MF-MF	273,809	0.126	0.124	-1.4
	4 Brother-Sister	800,127	0.375	0.376	0.4	XIII	74 M \leftarrow MF-MF-MF	160,726	0.102	0.098	-3.5
III	5 Father-Son	396,304	0.380	0.381	0.2	<i>aa-c'</i>	75 M \leftarrow MF-MF-FM	174,261	0.103	0.106	3.4
<i>aa-a</i>	6 Father-Daughter	376,255	0.321	0.321	0.1		76 M \leftarrow MF-FM-MF	158,401	0.107	0.109	1.9
	7 Mother-Son	422,374	0.366	0.367	0.2		77 M \leftarrow MF-FM-FM	160,105	0.106	0.106	0.3
	8 Mother-Daughter	400,337	0.347	0.349	0.5		78 M \leftarrow FM-MF-MF	147,949	0.102	0.103	0.9
IV	9 Brothers in-law (MF-M)	602,262	0.302	0.296	-2.1		79 M \leftarrow FM-MF-FM	156,876	0.103	0.111	7.9
<i>a-b</i>	10 Brother-Sister in-law (FM-M)	578,269	0.296	0.304	2.7		80 M \leftarrow FM-FM-MF	133,588	0.104	0.103	-1.0
	11 Brother-Sister in-law (MF-F)	650,127	0.298	0.307	3.0		81 M \leftarrow FM-FM-FM	131,756	0.101	0.101	-0.5
	12 Sisters in-law (FM-F)	596,540	0.278	0.277	-0.2		82 F \leftarrow MF-MF-MF	152,751	0.087	0.086	-0.1
V	13 Nephew-Uncle (BF)	280,067	0.254	0.249	-1.7		83 F \leftarrow MF-MF-FM	165,828	0.091	0.093	3.1
<i>aa-b</i>	14 Niece-Uncle (BF)	266,289	0.218	0.220	1.2		84 F \leftarrow MF-FM-MF	151,100	0.094	0.095	1.7
	15 Nephew-Uncle (BM)	312,019	0.241	0.238	-1.2		85 F \leftarrow MF-FM-FM	153,065	0.089	0.093	4.9
	16 Niece-Uncle (BM)	295,580	0.209	0.210	0.5		86 F \leftarrow FM-MF-MF	140,585	0.093	0.092	-1.1
	17 Nephew-Aunt (SF)	285,618	0.234	0.229	-2.1		87 F \leftarrow FM-MF-FM	150,162	0.097	0.099	2.9
	18 Niece-Aunt (SF)	270,325	0.217	0.203	-6.7		88 F \leftarrow FM-FM-MF	126,129	0.093	0.092	-1.2
	19 Nephew-Aunt (SM)	333,141	0.251	0.245	-2.3		89 F \leftarrow FM-FM-FM	124,968	0.085	0.090	5.3
	20 Niece-Aunt (SM)	316,625	0.234	0.218	-7.0	XIV	90 M \leftarrow MF-MF-MF \rightarrow M	<i>84,025</i>	<i>0.094</i>	<i>0.082</i>	<i>-13.4</i>
VI	21 Spouse of Sib-in-law (MF-FM)	252,232	0.252	0.246	-2.2	<i>aa-cc</i>	91 M \leftarrow MF-MF-FM \rightarrow M	<i>100,261</i>	<i>0.101</i>	<i>0.086</i>	<i>-15.2</i>
<i>a-b'</i>	22 Spouse of Sib-in-law (FM-MF)	226,795	0.229	0.232	1.1		92 M \leftarrow MF-FM-MF \rightarrow M	<i>93,237</i>	<i>0.105</i>	<i>0.090</i>	<i>-13.9</i>
	23 Spouse of Sib-in-law (MF-MF)	464,081	0.222	0.227	1.9		93 M \leftarrow FM-MF-MF \rightarrow M	<i>80,486</i>	<i>0.097</i>	<i>0.085</i>	<i>-12.0</i>
VII	24 Nephew-Aunt in-law (BF)	231,767	0.192	0.192	-0.3		94 M \leftarrow MF-MF-MF \rightarrow F	<i>79,690</i>	<i>0.087</i>	<i>0.073</i>	<i>-16.7</i>
<i>aa-b'</i>	25 Niece-Aunt in-law (BF)	221,287	0.172	0.171	-0.8		95 M \leftarrow MF-MF-FM \rightarrow F	<i>95,733</i>	<i>0.094</i>	<i>0.076</i>	<i>-19.9</i>
	26 Nephew-Aunt in-law (BM)	254,534	0.187	0.183	-2.2		96 M \leftarrow MF-FM-MF \rightarrow F	<i>89,364</i>	<i>0.093</i>	<i>0.080</i>	<i>-13.6</i>
	27 Niece-Aunt in-law (BM)	241,873	0.164	0.161	-2.0		97 M \leftarrow MF-FM-FM \rightarrow F	<i>95,020</i>	<i>0.095</i>	<i>0.075</i>	<i>-20.4</i>
	28 Nephew-Uncle in-law (SF)	227,403	0.190	0.188	-1.5		98 M \leftarrow FM-MF-MF \rightarrow F	<i>76,514</i>	<i>0.095</i>	<i>0.076</i>	<i>-20.0</i>
	29 Niece-Uncle in-law (SF)	215,068	0.163	0.167	2.2		99 M \leftarrow FM-FM-FM \rightarrow F	<i>89,054</i>	<i>0.088</i>	<i>0.079</i>	<i>-9.8</i>
	30 Nephew-Uncle in-law (SM)	264,524	0.197	0.198	0.8		100 M \leftarrow FM-FM-MF \rightarrow F	<i>77,332</i>	<i>0.094</i>	<i>0.076</i>	<i>-19.0</i>
	31 Niece-Uncle in-law (SM)	251,782	0.171	0.175	2.1		101 M \leftarrow FM-FM-FM \rightarrow F	<i>80,067</i>	<i>0.082</i>	<i>0.072</i>	<i>-12.9</i>
VIII	32 <i>Male Cousins (BF)</i>	<i>70,137</i>	<i>0.208</i>	<i>0.159</i>	<i>-23.8</i>		102 F \leftarrow MF-MF-MF \rightarrow F	<i>76,344</i>	<i>0.080</i>	<i>0.064</i>	<i>-20.3</i>
<i>aa-bb</i>	33 <i>Male Cousins (SM)</i>	<i>82,049</i>	<i>0.215</i>	<i>0.160</i>	<i>-25.4</i>		103 F \leftarrow MF-MF-FM \rightarrow F	<i>91,080</i>	<i>0.090</i>	<i>0.066</i>	<i>-26.6</i>
	34 <i>Male Cousins (SF)</i>	<i>156,747</i>	<i>0.202</i>	<i>0.152</i>	<i>-24.8</i>		104 F \leftarrow MF-FM-MF \rightarrow F	<i>84,736</i>	<i>0.092</i>	<i>0.070</i>	<i>-23.4</i>
	35 <i>Female Cousins (BF)</i>	<i>63,032</i>	<i>0.169</i>	<i>0.126</i>	<i>-25.5</i>		105 F \leftarrow FM-MF-MF \rightarrow F	<i>72,410</i>	<i>0.082</i>	<i>0.068</i>	<i>-17.4</i>
	36 <i>Female Cousins (SM)</i>	<i>73,649</i>	<i>0.197</i>	<i>0.124</i>	<i>-37.0</i>	XV	106 F-MF-MF-M	288,374	0.103	0.103	-0.2
	37 <i>Female Cousins (SF)</i>	<i>140,522</i>	<i>0.177</i>	<i>0.118</i>	<i>-33.2</i>	<i>a'-d</i>	107 F-MF-MF-F	312,703	0.102	0.105	3.5
	38 <i>Male-Female Cousins (BF)</i>	<i>144,100</i>	<i>0.179</i>	<i>0.141</i>	<i>-20.9</i>		108 F-MF-FM-M	311,795	0.111	0.113	1.4
	39 <i>Male-Female Cousins (SM)</i>	<i>170,577</i>	<i>0.196</i>	<i>0.141</i>	<i>-28.2</i>		109 F-MF-FM-F	162,928	0.099	0.104	5.4
	40 <i>Male-Female Cousins (BM)</i>	<i>148,691</i>	<i>0.179</i>	<i>0.133</i>	<i>-25.5</i>		110 F-FM-MF-M	308,163	0.116	0.115	-1.5
	41 <i>Male-Female Cousins (SF)</i>	<i>148,631</i>	<i>0.184</i>	<i>0.135</i>	<i>-26.5</i>		111 F-FM-MF-F	166,250	0.121	0.117	-2.6
IX	42 F-MF-M	461,883	0.185	0.191	3.5		112 F-FM-FM-M	304,684	0.114	0.114	0.3
<i>a'-c</i>	43 F-MF-F	500,448	0.192	0.196	1.8		113 M-MF-MF-M	278,416	0.117	0.111	-4.9
	44 F-FM-M	481,006	0.207	0.212	2.6		114 M-MF-FM-M	149,478	0.131	0.122	-7.0
	45 M-MF-M	447,263	0.208	0.207	-0.6		115 M-FM-MF-M	143,733	0.115	0.112	-2.2
X	46 MF-MF-M	362,409	0.156	0.157	0.8	XVI	116 MF-MF-MF-M	230,313	0.087	0.085	-2.5
<i>a-c</i>	47 MF-MF-F	393,579	0.156	0.161	3.4	<i>a-d</i>	117 MF-MF-MF-F	251,223	0.087	0.087	0.2
	48 MF-FM-M	375,442	0.179	0.173	-3.4		118 MF-MF-FM-M	248,811	0.097	0.093	-4.0
	49 MF-FM-F	391,389	0.158	0.160	1.2		119 MF-MF-FM-F	259,925	0.083	0.086	3.0
	50 FM-MF-M	353,470	0.160	0.161	0.8		120 MF-FM-MF-M	245,814	0.104	0.094	-9.7
	51 FM-MF-F	378,720	0.164	0.165	0.5		121 MF-FM-MF-F	265,220	0.101	0.096	-4.5
	52 FM-FM-M	341,316	0.157	0.160	2.1		122 MF-FM-FM-M	241,998	0.099	0.093	-6.0
	53 FM-FM-F	351,350	0.148	0.148	0.0		123 MF-FM-FM-F	248,449	0.084	0.086	1.7
XI	54 M \leftarrow MF-MF-M	202,632	0.119	0.127	6.7		124 FM-MF-MF-M	224,873	0.091	0.087	-5.1
<i>aa-c</i>	55 M \leftarrow MF-MF-F	219,007	0.129	0.130	1.1		125 FM-MF-MF-F	246,186	0.092	0.089	-3.9
	56 M \leftarrow MF-FM-M	192,819	0.134	0.140	4.6		126 FM-MF-FM-M	237,791	0.100	0.095	-5.1
	57 M \leftarrow MF-FM-F	199,811	0.129	0.129	-0.3		127 FM-MF-FM-F	247,495	0.088	0.088	0.0
	58 M \leftarrow FM-MF-M	183,670	0.125	0.133	6.2		128 FM-FM-MF-M	223,661	0.086	0.087	0.3
	59 M \leftarrow FM-MF-F	196,631	0.132	0.136	3.6		129 FM-FM-MF-F	240,328	0.094	0.089	-5.8
	60 M \leftarrow FM-FM-M	160,857	0.132	0.132	0.6		130 FM-FM-FM-M	213,155	0.091	0.086	-5.5
	61 M \leftarrow FM-FM-F	164,528	0.122	0.122	-0.2		131 FM-FM-FM-F	220,553	0.084	0.079	-4.9
	62 F \leftarrow MF-MF-M	192,818	0.104	0.112	7.1	XVII	132 MF-MF-MF-MF	<i>176,790</i>	<i>0.071</i>	<i>0.066</i>	<i>-8.3</i>
	63 F \leftarrow MF-MF-F	208,008	0.114	0.114	0.2	<i>a-d'</i>	133 MF-MF-MF-FM	<i>199,041</i>	<i>0.075</i>	<i>0.071</i>	<i>-6.0</i>
	64 F \leftarrow MF-FM-M	183,929	0.116	0.123	6.1	XVIII	134 MF-MF-MF-MF-M	<i>153,057</i>	<i>0.047</i>	<i>0.046</i>	<i>-3.3</i>
	65 F \leftarrow MF-FM-F	191,177	0.112	0.113	1.2	<i>a-e</i>	135 FM-FM-FM-FM-F	<i>144,976</i>	<i>0.054</i>	<i>0.043</i>	<i>-20.1</i>
	66 F \leftarrow FM-MF-M	175,507	0.110	0.119	8.0	XIX	136 MF-MF-MF-MF-MF	<i>117,473</i>	<i>0.047</i>	<i>0.035</i>	<i>-25.5</i>
	67 F \leftarrow FM-MF-F	187,178	0.121	0.122	0.5	<i>a-e'</i>	137 MF-MF-MF-MF-FM	<i>135,096</i>	<i>0.042</i>	<i>0.038</i>	<i>-9.9</i>
	68 F \leftarrow FM-FM-M	151,606	0.112	0.118	5.5	XX	138 MF-MF-MF-MF-MF-M	<i>106,844</i>	<i>0.031</i>	<i>0.025</i>	<i>-21.9</i>
	69 F \leftarrow FM-FM-F	155,658	0.113	0.109	-3.7	<i>a-f</i>	139 FM-FM-FM-FM-FM-F	<i>100,871</i>	<i>0.043</i>	<i>0.023</i>	<i>-46.5</i>
XII	70 MF-MF-MF	278,938	0.122	0.122	-0.5	XXI	140 MF-MF-MF-MF-MF-MF	<i>82,523</i>	<i>0.032</i>	<i>0.019</i>	<i>-40.0</i>
<i>a-c'</i>	71 MF-MF-FM	310,160	0.132	0.132	-0.6	<i>a-f'</i>	141 MF-MF-MF-MF-MF-FM	<i>96,840</i>	<i>0.027</i>	<i>0.021</i>	<i>-24.4</i>

Notes: M/F indicate gender, MF or FM are spouses, - indicates a sibling link and \rightarrow indicates a parent-child link. Other abbreviations are BF=Brother of the father, BM=Brother of the mother, SF=Sister of the father and SM=Sister of the mother. Moments printed in italics were not used in the calibration. The sample correlations for cousins are subject to limitations discussed in Section 4.6.

Figure 2: Baseline Fit in Swedish Registers

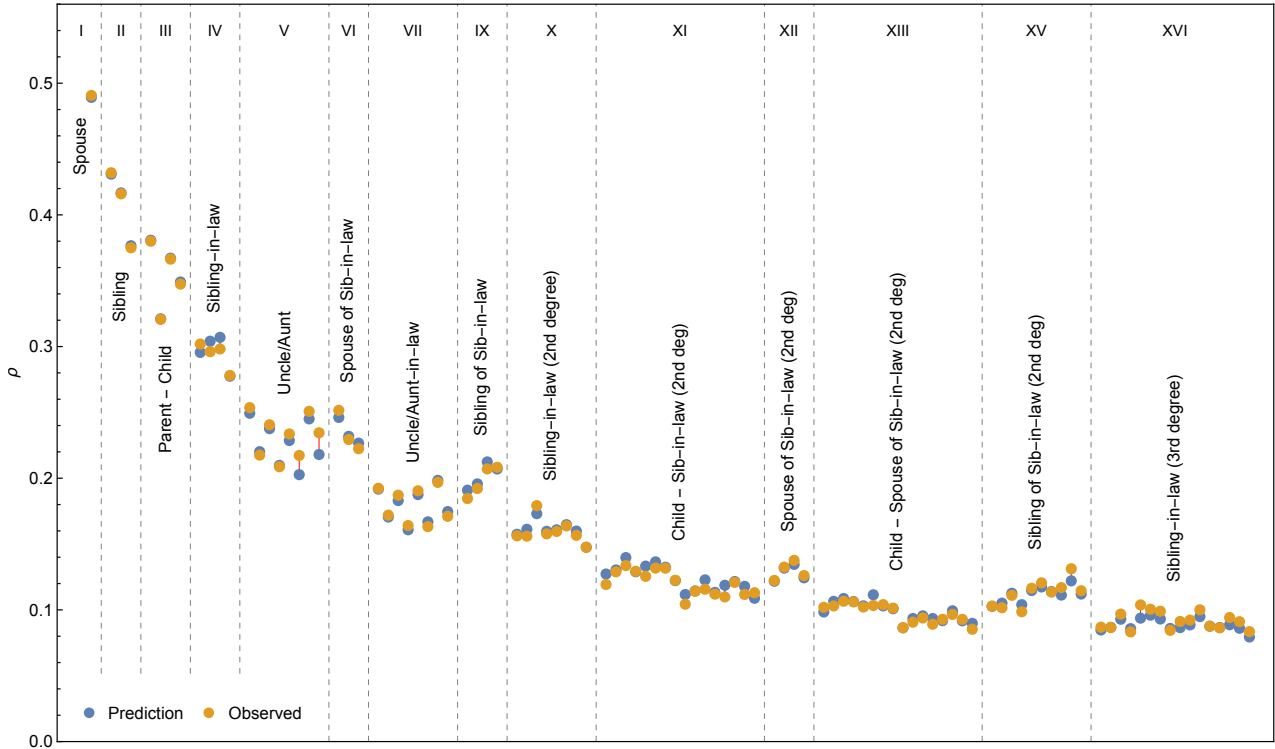

Notes: See Table 3 for the corresponding list of kinship moments.

success of future descendants. With $\hat{\beta}^m = 0.14$ and $\hat{\beta}^f = 0.13$, the direct transmission channel contributes very little to the overall transmission of status from one generation to the next. Accordingly, only 1-2% of the variation in offspring education is explained by parental education (see Panel D).²⁶

Instead, the transmission of advantages occurs predominantly via the latent factor, as measured by the parameters γ^k . We find $\hat{\gamma}^m = 0.66$ and $\hat{\gamma}^f = 0.57$, implying that the set of unobserved advantages that this factor represents are much more strongly transmitted from parents to their children than educational attainment itself.²⁷ Moreover, this latent factor explains up to 45% of the variance in child education (cf. $\sigma_{z^k}^2/\sigma_{y^k}^2$).

Our results here are broadly consistent with findings from alternative methods. First, they are consistent with recent multigenerational studies, which find that kinship correlations decline more slowly across generations than a simple iteration of the parent-child correlation would suggest (Lindahl et al. 2015, Braun and Stuhler 2018). For example,

²⁶Accordingly, the relative weights of mothers and fathers α_y^m and α_y^f are not consequential.

²⁷The parameter γ captures the influence of both parents. As also reported in Panel A, the implied correlations between the latent factors of the child and the father *or* mother are slightly lower because of imperfect assortative mating between spouses ($\rho_{z^m z^f} < 1$).

Table 4: Calibrated Parameters in Swedish Registers (Years of Schooling)

<i>Panel A: Intergenerational Processes</i>							
β^m	β^f	γ^m	γ^f	σ_{ym}^2	σ_{yf}^2	σ_{zm}^2	σ_{zf}^2
0.144	0.129	0.664	0.566	4.648	4.465	2.072	1.559
a_{ym}	a_{yf}	a_{zm}	a_{zf}	σ_{um}^2	σ_{uf}^2		
0.389	0.018	0.660	0.775	1.975	2.333		
<i>Ancestor correlations in y and z:</i>							
	Father-Son	Fr.-Daughter	Mother-Son	Mother-Daughter			
<i>in z</i>	0.586	0.601	0.526	0.508			
	Father-Son	Grandfr.-Son	GGrandfr.-Son	GGrandfr.-Son			
<i>in y</i>	0.381	0.209	0.121	0.071			
<i>in z</i>	0.586	0.344	0.201	0.118			
<i>Panel B: Sibling Processes</i>							
	σ_{xm}^2	σ_{xf}^2	σ_{xmf}	σ_{em}^2	σ_{ef}^2	σ_{emef}	
	0.180	0.244	0.068	0.657	0.712	0.625	
<i>Sibling correlations in y and z:</i>							
	Brothers	Sisters	Mixed		Brothers	Sisters	Mixed
<i>in y</i>	0.431	0.416	0.376	<i>in z</i>	0.677	0.825	0.711
<i>Panel C: Assortative Processes</i>							
r_{zz}^m	r_{zy}^m	r_{yz}^m	r_{yy}^m	r_{zz}^f	r_{zy}^f	r_{yz}^f	r_{yy}^f
0.662	-0.008	0.696	0.143	0.747	0.113	0.661	0.249
<i>Spousal correlations in y and z:</i>							
ρ_{ymyf}	ρ_{zmzf}	ρ_{ymzf}	ρ_{zmzf}				
0.489	0.754	0.539	0.580				
<i>Panel D: Variance Decomposition of y</i>							
	\tilde{y}_{t-1}	\tilde{z}_{t-1}	$\sigma_{\tilde{y}\tilde{z}}$	$\Sigma_{\tilde{y},\tilde{z}}$	x_t	e_t	$\Sigma_{\tilde{y},\tilde{z},x,e}$
<i>male</i>	1.5%	16.1%	7.5%	25.1%	3.9%	14.1%	43.1%
<i>female</i>	1.6%	12.9%	5.7%	20.2%	5.5%	15.9%	41.6%

Notes: Panels A and B report parameter estimates and implied ancestor and sibling correlations in educational attainment y and latent advantages z . The parameters β and σ_y^2 capture the direct transmission and variance of y ; γ and σ_z^2 the transmission and variance of z ; and σ_x^2 and σ_e^2 shared sibling influences in y and z ; see equations (1)-(3) for details. Panel C reports the coefficients from the linear projections (4) and (5) of z^k and y^k for $k = f, m$ on their spouse's z and y and the implied spousal correlations. Panel D decomposes σ_y^2 into the components explained by the parents' y (\tilde{y}_{t-1}) and z (\tilde{z}_{t-1}) and their covariance ($\sigma_{\tilde{y}\tilde{z}}$), and the sibling components in y (x_t) and z (e_t); $\Sigma_{\tilde{y}\tilde{z}}$ and $\Sigma_{\tilde{y},\tilde{z},x,e}$ are the total percentages explained by the parents and the close family (parental and shared sibling influences), respectively. Based on the kinship correlations reported in Table 3.

the great-grandfather and grandfather-son correlations as predicted by our baseline model (0.121 and 0.209, Panel A of Table 4) are similar to direct estimates from a Swedish data set by Lindahl et al. (0.113 and 0.226, their Table A3). The predictions deviate more for grandparent-daughter pairs, but are still within the confidence intervals of the direct estimates. This similarity is notable, as higher-order autocorrelations across three or more generations were not targeted by our calibration.

Second, our findings are in line with recent name-based evidence, which suggests that the average status of surnames regresses more slowly to the mean than individual status

(Clark, 2014). Within our model, this pattern is explained by the fact that relatives are more similar in their latent endowments z than they are in their observable status y , such that averaging across distant relatives distills a more concentrated measure of those latent endowments. While our data do not contain surnames, we can illustrate this implication using direct family links. As shown in Online Appendix G.1, we find a much higher intergenerational correlation in family average as compared to individual outcomes.

Finally, we compare our results to estimates by Adermon, Lindahl and Palme (2021) [ALP], who use a similar “horizontal” data structure but a different methodology, directly regressing child human capital (years of schooling or grade point average) on observable characteristics in the extended family. Their baseline estimates suggest that 17.2% of the variation in child education can be explained by educational outcomes in the extended family, increasing to 20.2% when incorporating information on income and social stratification.²⁸ In comparison, our estimates imply that parental background determines 20.2% (females) or 25.1% (males) of the variation in educational attainment (see $\Sigma_{\tilde{y}, \tilde{z}}$ in Panel D in Table 4).²⁹ Our estimates are therefore slightly larger than the baseline estimates in ALP, in line with their argument that those baseline estimates represent a lower bound, as human capital can only be imperfectly measured in the data (see Section 2 in ALP).

Our approach abstracts from this measurement issue by quantifying the importance of family background indirectly, and therefore yields larger estimates. It shares similarities with an instrumental variable (IV) approach, in which a distant kin is used to instrument for the parent’s outcome in a parent-child regression (see Section 3.2). ALP complement their baseline estimates by using horizontal kins in the parent generation as instruments (Section 5 in ALP). In a simplified version of our model, their IV approach identifies the effect of family background on *latent* advantages z (rather than its effect on education y , see Online Appendix B.2). While explaining up to 25.1% of the variation in y , we find that parental background explains more than 36% of the variation in z .³⁰

²⁸See Table 1 in ALP. Rather than the R^2 , ALP focus on the sum of regression coefficients as their preferred estimator. This sum of coefficients represents the effect of raising the schooling of *all* extended kins by one standard deviation. In contrast to the R^2 , it abstracts from the actual covariance between kins (see Appendix A.3 in ALP). It therefore represents the effect of a particular change in family background, irrespectively of how likely that change is given the observed covariance between kins (e.g., it might be unlikely that all kins have high schooling if that covariance is low). Because our estimates are based on fitting that covariance they relate to the R^2 rather than the sum of coefficients.

²⁹These estimates do not yet account for shared sibling influences that are orthogonal to parental advantages encapsulated in \tilde{y}_{t-1} and \tilde{z}_{t-1} (see next Section).

³⁰The variance share of z_t^k explained by \tilde{z}_{t-1} equals $(\gamma^k)^2 \frac{\text{Var}(\alpha_z^k z_{t-1}^m + (1-\alpha_z^k) z_{t-1}^f)}{\text{Var}(z_t^k)}$, estimated to be 36.0% for men and 36.8% for women. We therefore find that parental background has a similar effect on the

The key advantage of our findings here compared to previous studies is that they are based on an explicit intergenerational and assortative model. We can therefore derive specific predictions for all kinship moments from our model (as in Table 3) and test whether those predictions fit the data. We provide additional evidence on model fit below. Moreover, we can quantify not only the overall importance of family background, but also decompose this overall effect into intergenerational, sibling and assortative processes. Such decompositions are necessary to understand certain aspects of intergenerational transmission, such as the degree to which status differences persist between families.³¹

4.4 Siblings and Horizontal Transmission

Our model allows for common shocks among siblings, over and above their shared exposure to parental advantages y_{t-1}^k and z_{t-1}^k . We find that siblings share both observable and latent advantages, as summarized in Panels B and D of Table 4. The shared sibling component in the observable outcome x_t^k explains about 5% and the shared component in the latent factor e_t^k about 15% of the variation in years of schooling (see Panel D). Moreover, e_t^k explains between 30 and 45% of the variation in the latent factor itself.

Siblings share, therefore, important influences over and above what can be accounted for by parental characteristics. This finding is consistent with the literature on sibling correlations, which has shown that siblings share many additional influences that are orthogonal to the observed socioeconomic status of parents (see Jäntti and Jenkins 2014, and Section 2.4). However, our results provide a richer characterization of this process. In particular, they suggest that most of the advantages that siblings share are *not* reflected in observables such as education or income.

Intuitively, while the correlation in their observables is fairly high, siblings must be substantially more similar to explain why kinship correlations decay so slowly across siblings-in-law. Depending on gender, the implied correlation between the latent status of siblings ranges between 0.68 and 0.82, which is more than 50% higher than the sibling correlation in years of education (Panel B of Table 4).³² These correlations correspond to variance

latent advantages of male and female children, but a larger effect on the education of male children.

³¹To see that this is the case, note that if sorting is random (i.e., $\rho_{z^m z^f} = 0$) then status differences are not very persistent even if child outcomes are *perfectly* determined by family background (e.g., $\gamma = 1$ and $\sigma_y^2 = \sigma_z^2$). Estimates of the overall importance of family background in itself are therefore not fully informative about the persistence of status differences across generations.

³²The correlation between the *latent* status of siblings appears therefore as high as the correlation

shares, so shared environmental and family influences explain between 41.6% and 43.1% of the variation in education y (see $\Sigma_{\bar{y},\bar{z},x,e}$ in Panel D), but between 67.7% and 82.5% of the variation in latent advantages z that determine the prospects of the next generation. Our findings therefore imply that sibling correlations – traditionally viewed as a particularly comprehensive measure (Jäntti and Jenkins, 2014) – still understate the importance of family influences. They also support the view that empirical studies have understated *inequality of opportunity*, as many childhood circumstances are not directly observed in the data (Roemer and Trannoy, 2016; Hufe et al., 2017).

4.5 Assortative Mating

The spousal correlation in years of schooling is one-half in our data (see Table 3), in line with prior evidence from Sweden and other countries (Raaum et al., 2007). But while the similarity of spouses in *observable* characteristics is well quantified, our model also accounts for assortative mating in unobservable determinants of child outcomes. The results are reported in Panel C of Table 4. In the projection of z_{t-1}^f and y_{t-1}^f on z_{t-1}^m and y_{t-1}^m , the latent status of the female z_{t-1}^f is predominantly explained by the latent status of the spouse (r_{zz}^m), while his education has no additional predictive power (r_{zy}^m). However, his education does have some predictive power for her educational attainment (r_{yy}^m), over and above what can be explained by his latent factor (r_{yz}^m). The corresponding projection coefficients for males are similar. These results suggest that the spousal correlation in schooling is predominantly a by-product of sorting in latent characteristics.

A key parameter for understanding the transmission of socioeconomic inequalities across generations is thus the degree of assortative mating in latent advantages. By comparing the correlations between close and more distant kins, our approach offers an estimate of that parameter. The spousal correlations implied by the parametrization of our model are reported in the last block in Panel C of Table 4. The first entry is the calibrated spousal correlation in education, which at $\rho_{y^m y^f} = 0.49$ is very similar to its sample counterpart. At $\rho_{z^m z^f} = 0.75$, the implied spousal correlation in z is substantially higher. Intuitively, while the spousal correlation in educational attainment is high, it is far too low to explain the slow decay of kinship correlations between distant relatives observed in our data.

between the *educational attainment* of “identical” (monozygotic) twins. This observation suggests that non-genetic latent advantages are an important determinant of educational attainment. We decompose latent into genetic and non-genetic advantages in Section 5.

Spouses must therefore be much more similar in those factors that determine the prospects of their children than they are in educational or other observable characteristics. The observation that the implied correlation in latent advantages is as high for spouses as for siblings may further suggest that those advantages primarily reflect non-genetic rather than genetic advantages, a hypothesis that we study further in Section 5.

4.6 Fit and Robustness

We can use the comparatively large set of empirical moments to study the robustness of our model fit. In a first robustness exercise, we drop two thirds of our baseline moments (kinship groups X and higher), reducing the set from 105 to 35 moments. Because we drop all distant kins, this exercise also tests our model’s capability to extrapolate distant kinship correlations from closer kins. Our parameter estimates remain quite stable. Figure 3 plots the out-of-sample fit for the 70 excluded correlations. The calibrated model predicts a diverse set of moments not included in the calibration, including vertical, horizontal and distant kinships. Our baseline results are therefore robust to the choice of moments, as well as to various issues related to the measurement of those moments.³³

However, our model does not provide a good fit for two kinship types, *cousins* and *very distant* in-laws. Our baseline calibration understates the correlation between cousins by around 25%, and the correlations for in-laws of four or more degrees of separation by an even larger amount (although the deviations are small in absolute value). These gaps close only partially if we directly target those moments in the calibration. Further examination suggests that the gap for cousins reflects primarily a measurement problem, while the gap for distant kinship correlations appears to reflect a limitation of our model.

Because they are identified via their shared grandparents, we draw cousins from a narrower and more recent range of cohorts (to avoid selection issues with respect to the parent or grandparent age; see Section F in the Online Appendix). This causes two issues. The

³³Sampling variation is negligible and not a major concern. Measurement error in the outcome variable would have only limited effects as well. Classical measurement error would decrease all kinship correlations by the same proportion, which would have no effect on the parameter estimates if $\beta = 0$ (as the parameter are then identified as ratios of correlations) and only small effects on our baseline results with $\beta \neq 0$ (see Appendix J.4). Instead, we are concerned about a conceptual mismatch between the population that we sample from and its theoretical counterpart (e.g., due to variation in kinship correlations over time). We perform three different tests (see Online Appendix E), studying the behavior of the objective function around the minimum, and showing that our results and predictions are robust to small perturbations in the parameter estimates or empirical correlations.

Figure 3: Out-of-Sample Fit in Swedish Registers

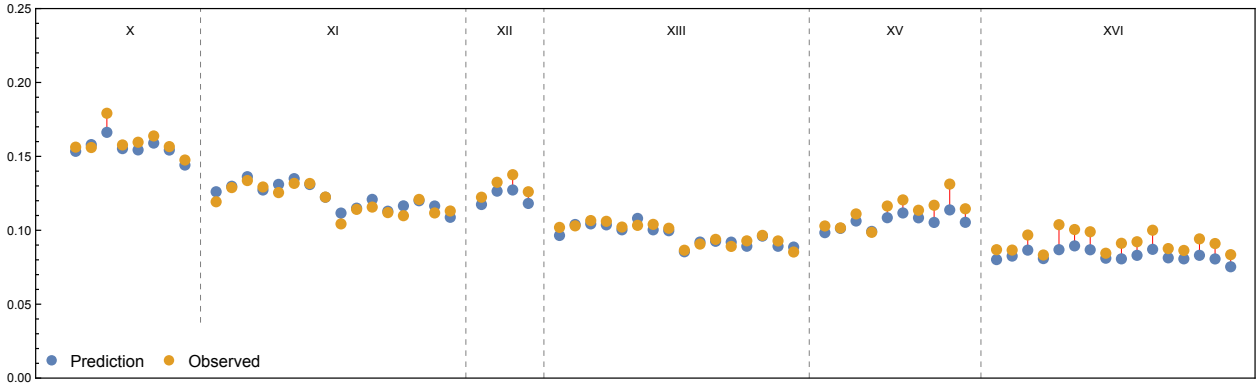

first is that the moments that we wish to explain may vary over time (see [Atkinson and Jenkins, 1984](#)). Indeed, the cousin correlations for earlier cohorts are lower and more similar to estimates reported by [Hällsten \(2014\)](#).³⁴ Second, kinship correlations decrease with the age gap between kins, suggesting that the cousin correlation is upward biased in our sample (as the underlying cohort range is narrower than for other moments). As shown in [Online Appendix F.3](#), this upward bias explains half of the gap between the theoretical and sample correlations for cousins. While we do not include cousins in our calibration, including them has only negligible effects on our parameter estimates.

In contrast, our model’s tendency to understate the most distant kinship correlations (cf. in-laws of 4th or 5th degrees of separation in [Table 4](#)) cannot be due to their variability over time. The time trends for siblings-in-law – which can be estimated for a wide range of cohorts – appear quite stable. Instead, we might understate the similarity of very distant kins because our model accounts for only a *single* latent factor. Typically, the latent factor is thought to summarize the influence of many transmission channels, such as cultural, genetic, or social determinants ([Becker and Tomes 1986](#)). However, some determinants may have higher rates of persistence than others, and those with the strongest persistence will explain a greater share of the most distant kinship correlations.³⁵ A model with a single latent factor may therefore still understate the similarity of *very* distant kins.

³⁴We estimated the time trends in the kinship correlations using a two-step procedure, see [Section F](#) in the [Online Appendix](#). [Hällsten \(2014\)](#) estimates a cousin correlation of 0.15, which is similar to the *predicted* cousin correlations from our calibrated model.

³⁵[Stuhler \(2012\)](#) argues that this “multiplicity” of transmission mechanisms is one explanation why multigenerational correlations do not decay as quickly as a model with a single factor would suggest. Models with persistent group membership can be seen as the extreme case of this argument. For example, [Becker and Tomes \(1986\)](#) include group dummies to account for the persistence of racial gaps.

4.7 Restricted Models

One may ask whether our model could be simplified without significantly reducing its ability to explain the transmission of socioeconomic inequality. Figure 4 provides evidence on this question. We first consider a restricted model without “direct” sorting and transmission of educational attainment (i.e., imposing $\beta^m = \beta^f = 0$ and setting the coefficients of y_{t-1}^m in the linear projections (4) and (5) to zero), for which we show identification in Online Appendix B.2.³⁶ This restricted model explains the data nearly as well (see Figure 4a), consistent with the observation that the direct transmission channels are not important in our benchmark (explaining less than 2% of the variation in y). However, it understates the spousal correlation in educational attainment.

In contrast, it is crucial to allow for the transmission of latent advantages, as the restriction $\gamma^m = \gamma^f = 0$ results in a very poor fit (see Figure 4b). With this restriction, the intergenerational transmission has to be captured by direct mechanisms instead (we find $\beta^m = 0.61$ and $\beta^f = 0.54$). While some kinship correlations are understated (such as the spousal correlation, moment group I), others are greatly overstated. It is also important to account for shared influences among siblings. The fit of a restricted model in which all sibling components have zero variance ($\sigma_{x^m}^2 = \sigma_{x^f}^2 = \sigma_{e^m}^2 = \sigma_{e^f}^2 = 0$) is much worse than the fit of the benchmark model (see Figure 4c). The sibling correlations (group II) are heavily understated, as siblings share distinct influences over and above the average intergenerational transmission. The correlations for distant siblings-in-law are also understated, as they depend on the similarity of siblings.

Finally, we assume that assortative mating occurs exclusively in the observed outcome, as has been the standard choice in the literature. Specifically, this means that the coefficients of z_{t-1}^m in the linear projections (4) and (5) are restricted to zero. With this more restrictive assortative process, the model does not explain the data well (see Figure 4d). The spousal correlation is overstated by 45% (0.71, outside of the plot area). The sibling (group II) and sibling-in-law (group IV) correlations are substantially understated, while the distant in-law correlations are overstated. The assortative mating in latent advantages is therefore crucial to understand the pattern of socioeconomic inequality across kins.

In sum, these results suggest that all components of our model matter, except of the

³⁶The key parameter estimates of this restricted model are $\gamma^m = 0.719$, $\gamma^f = 0.628$, $\sigma_{z^m}^2 = 2.742$, $\sigma_{z^f}^2 = 2.509$ and $\rho_{z^m z^f} = 0.802$. The implied ancestor correlations in y and z are slightly higher than in our baseline calibration.

Figure 4: Restricted Models

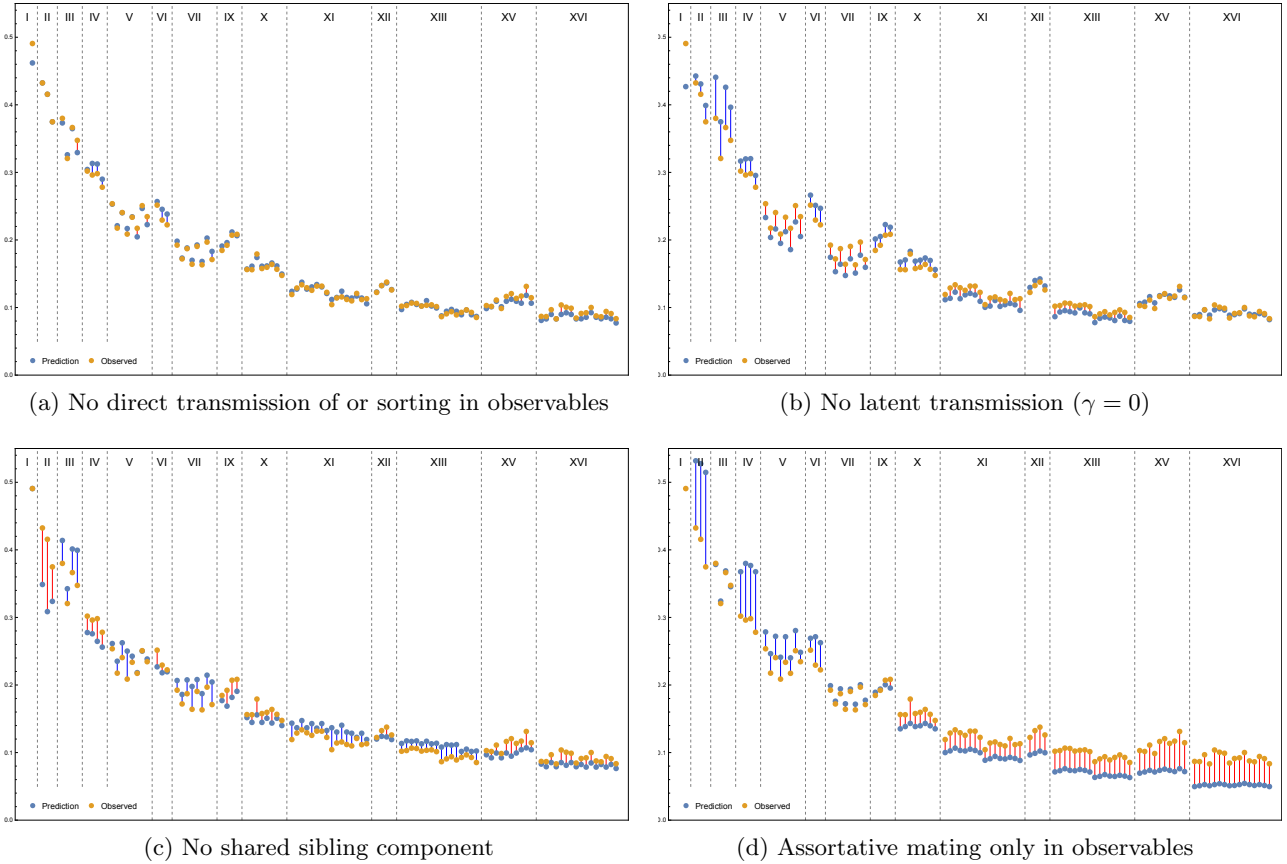

direct transmission and sorting in y . We nevertheless retain these pathways in our model because they are considered in other work, and might matter more for other outcomes (as we test below). The latent pathways are key components of the model. Based on our results, it seems doubtful that models that do not account for latent intergenerational and assortative processes (or similar forms of unobserved heterogeneity) could fit the pattern of socioeconomic inequality across kins. This finding is based on the observation of many kinship moments. As we show below, it is much harder to discriminate between different models based on the narrow set of moments typically used in the literature.

4.8 Other Outcomes and Other Samples

Income. Education is the key mediator for socioeconomic status in standard models in economics and sociology (see Goldthorpe 2014). Still, its transmission may follow distinct patterns that may not generalize to other measures. To study this question, we calibrate our model using *income* as a more direct measure of economic advantages. Our primary

measure is the logarithm of *ten-year* averages of annual total pre-tax income, centered around age 35 for children and age 45 for parents (see Section 3.1). We use the same 105 moments as in our baseline calibration for education. As shown in Online Appendix G, the calibrated model explains the data well, providing a close fit to both vertical and horizontal moments, and both consanguine and affine relationships.³⁷ The results have to be interpreted with caution, because women’s labor force participation is lower and their income therefore a noisier measure of “potential income” compared to men. If this was just due to pure noise, our model could account for it, and we would just obtain that the latent factor explains a lower share of the variance of income for females than for males (as our results suggest). However, the relation between women’s potential and actual income is likely more complicated, as labor supply decisions may interact within households.

Our approach delivers some interesting results. First, the latent determinants of income are more strongly transmitted than income itself across all three dimensions (intergenerational, sibling and assortative), for men and women. Second, we find a very large assortment in the latent factor ($\hat{\rho}_{zmf} = 0.80$) compared to the assortment in observables ($\hat{\rho}_{ymyf} = 0.12$): even though spousal correlations in income are very small, the determinants of income must be very strongly correlated to explain that the sibling-in-law correlations are not much smaller than the sibling correlations. Third, the implied father-son correlation in the latent factor is lower for income than for education, suggesting that those factors that determine educational attainment are more strongly transmitted between generations than those that determine income.³⁸ Fourth, we find strong gender symmetry in the transmission of those latent determinants of income, even though the observed correlations in income involving mothers or daughters are very small compared to those involving fathers and males.³⁹

Spanish data. To illustrate its feasibility in settings with scarcer data, we also apply our approach to a sample from the 2001 Spanish Census (INE, 2001). In contrast to the Swedish registers, our Spanish sample is limited to a single region (*Cantabria*) and lacks family links. To recover kinships, we exploit that children in Spain inherit surnames from both their parents, allowing us to track both maternal and paternal lines with a

³⁷Alternative income definitions yield similar results, but the variance shares explained by the latent factor z and the sibling component x increase in the quality of the income measure (i.e., are about twice as large when using 10-year averages instead of annual incomes).

³⁸Our finding of a small direct effect of parental income (β^k) is consistent with evidence that the causal effect of parental income is not large, except for low-income families (Loeken, Mogstad and Wiswall, 2012).

³⁹This result follows from the observed symmetry across extended kins. For example, uncles and nephews show very similar correlations irrespectively of whether the uncle is the brother of the mother or the father.

Figure 5: Actual vs. Placebo Kins

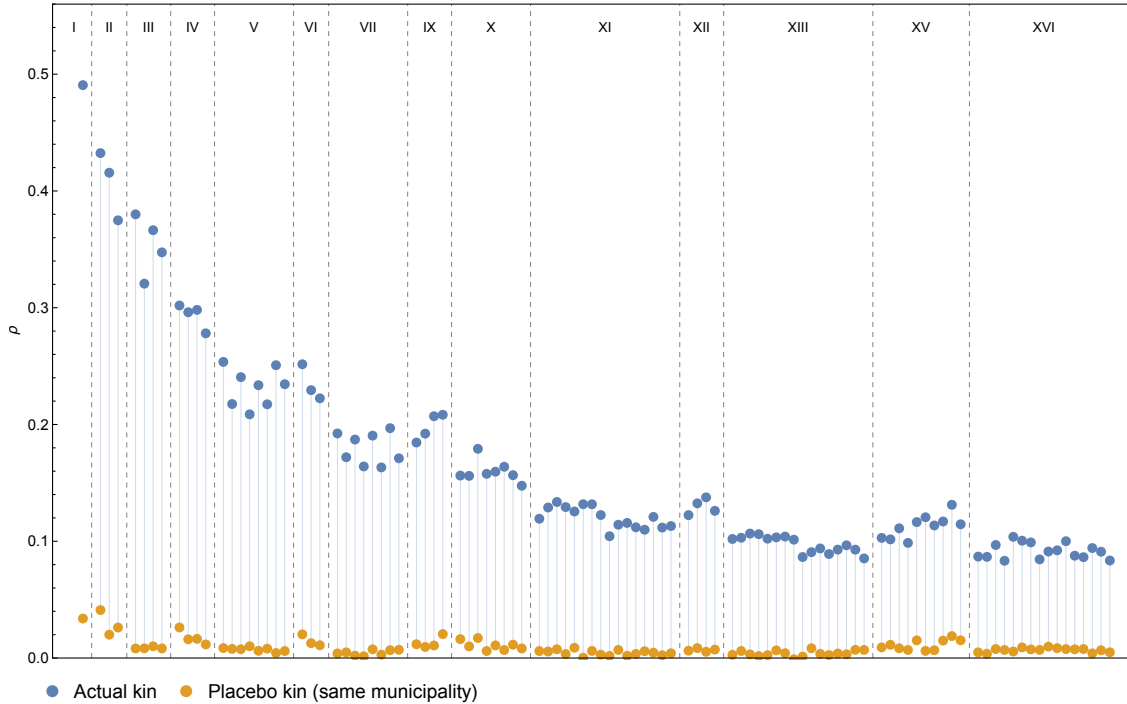

comparatively high match rate of around 36%. We find that the pattern of inequality transmission in Spain is qualitatively similar (see Online Appendix H), but at around 0.9 the implied spousal correlation in the latent factor is even higher than in Sweden.

4.9 Causal Pathways: Geography

The latent variable z in our model may represent a great variety of causal pathways. One hypothesis is that the similarity in socioeconomic status of distant kins can be partially explained by their *location*. To quantify the contribution of geography, we reestimate each of our 141 kinship moments but replace the actual kin with another person from the same municipality (and birth year).⁴⁰ These “placebo kins” capture to what extent location could explain the correlation patterns between kins. Figure 5 compares the sample correlations for actual kins (blue dots) with the corresponding correlations for placebo kins (orange dots). The placebo correlations are always positive, suggesting that geography does matter. However, geography explains only a small fraction of the correlations between kins (on average, less than 5%). While location is one plausible component of the latent factor, it is not an important one.

⁴⁰We observe the municipality of residence in 5-year intervals, and define an individual’s location based on the observation that falls into the age range 15-19.

5 Modeling Genetic and Non-Genetic Pathways

Our objective so far was to quantify how strongly advantages are transmitted from one generation to the next, while remaining agnostic about the specific causal mechanisms that the intergenerational and assortative components of our model represent. However, our approach can be used to distinguish between different mechanisms, to the extent that they have specific statistical implications about the correlation pattern across kins. For instance, although we do not observe genes, we can study whether genetic transmission mechanisms could contribute to the high persistence in latent advantages that we observed. We first illustrate that our model nests the standard model of genetic transmission with assortative mating, and test if this genetic model can explain the kinship pattern in educational attainment (Section 5.1). We then generalize our baseline model to separate the contribution from *genetic* and *non-genetic* latent pathways (Section 5.2).

5.1 A Standard Model from Quantitative Genetics

In the standard model in quantitative genetics, the observed outcome or “*phenotype*” is determined by genetic and environmental factors. The role of genes in vertical transmission is clear: each individual receives half of its genetic contribution from the father and the other half from the mother. In the simplest form, the model assumes that genetic and environmental factors contribute additively to the phenotype, i.e., do not interact and are uncorrelated. The role of genes in the horizontal dimension is less obvious, but the standard assumption is that assortative mating is based on similarity in the phenotype.⁴¹

This genetic model is nested in our general model by imposing three sets of restrictions. First, the parental outcome (phenotype) does not have any direct association with the child outcome (imposing the restrictions $\beta^k = 0$, $k = f, m$). Second, because the latent factor represents genes, it is transmitted from parents to children as

$$z_t^k = \frac{z_{t-1}^m + z_{t-1}^f}{2} + v_t^k \quad (7)$$

where v_t^k is uncorrelated across relatives and to z_{t-1}^m and z_{t-1}^f (imposing $\gamma^k = 1$, $\alpha_z^k = 0.5$, and $\sigma_{e_k}^2 = 0$, $k = f, m$). Finally, assortative mating occurs only in the outcome

⁴¹In Online Appendix C we obtain formulas for the correlations between relatives that coincide with the ones in, for example, Crow and Felsenstein (1968).

Figure 6: Model Fit (Standard Genetic Model, Education)

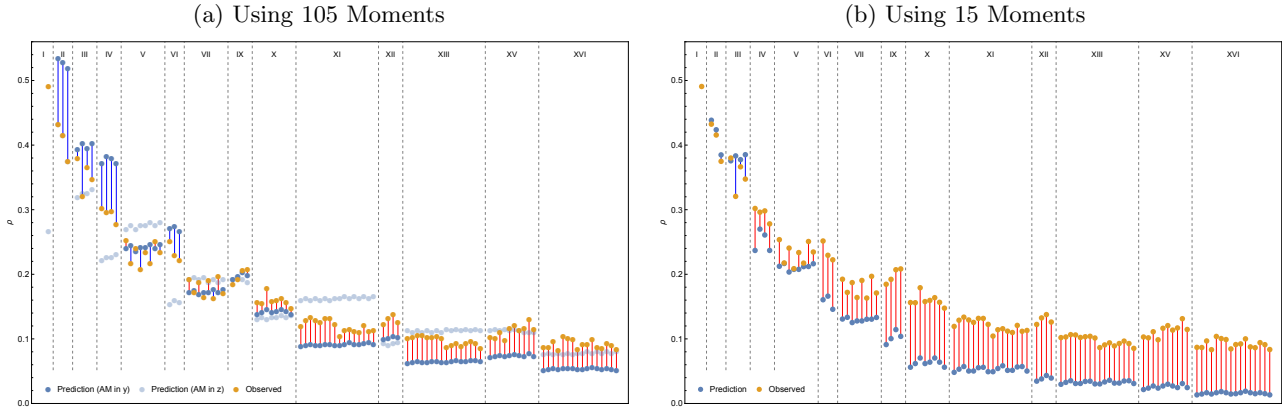

Notes: See Table 3 for the corresponding list of sample moments.

(phenotype) y , such that the coefficients of z^m in the linear projections of y^f and z^f on the spousal y^m and z^m are zero. As a consequence, $\rho_{z^m y^f}$, $\rho_{y^m z^f}$ and $\rho_{z^m z^f}$ are functions of $\rho_{y^m y^f}$ and some of the other parameters of the model. This genetic model has only five parameters, which account for the share of variance in the phenotype explained by the genotype (i.e. *heritability*, $\sigma_{z^m}^2 = \sigma_{z^f}^2 = \sigma_z^2$), the environmental effects shared by siblings ($\sigma_{x^m}^2$, $\sigma_{x^f}^2$ and $\sigma_{x^m x^f}$), and the assortative mating in the phenotype ($\rho_{y^m y^f}$).

While the assumption of phenotypic assortment has been standard in quantitative genetics, recent work implies that the similarity between spouses' genetic propensity for education is greater than would be implied by phenotypic assortment (Robinson et al. 2017). Clark (2021) proposes a variant in which assortative mating occurs in the genotype z rather than the phenotype y , demonstrating the fit of this model in data from England from the mid-eighteenth century. We also consider this alternative genetic model below.

The Standard Genetic Model and *Education*. We calibrate the model for *years of schooling*, using the same 105 kinships as used for calibration of our baseline model. Figure 6a illustrates the in-sample fit, to be compared against the fit of our baseline model (Figure 2). The standard genetic model with assortative mating in the phenotype y (dark blue dots) fits substantially worse, overstating kinship correlations within the nuclear family while understating those for more distant relatives. Its in-sample mean prediction error is 24.3%, compared to 2.5% for our baseline model. The fit of the genetic model with assortative mating in the genotype z (light blue dots) is only slightly better.

Our findings are therefore inconsistent with a purely genetic interpretation. We base this

rejection on a simple statistical observation – the genetic model is not able to provide a close in-sample fit to the distribution of educational advantages across kins. However, this observation is not necessarily inconsistent with the view that genes are one of the decisive factors in the transmission from parents to their children. Instead, we reject the *standard* genetic model from quantitative genetics, in particular the assumption that assortative mating occurs only on the phenotype. Spouses must be far more similar in the determinants of socioeconomic success than is reflected in their educational attainment.

This finding is based on the observation of distant siblings-in-law – intuitively, the failure of assortative assumptions becomes more evident in distant kinship correlations that are a function of multiple assortative matches. In contrast, the genetic model *appears* to perform well when fitting a restricted set of correlations that includes only close kins. To illustrate this point, we recalibrate the standard genetic model with phenotype mating using only sibling correlations (group II in Table 3), parent-child correlations (group III), and nephew/niece/uncle/aunt correlations (group V). As shown in Figure 6b, the genetic model provides an excellent in-sample fit for those 15 close kinships. However, it provides an extremely bad fit to all other moments. To evaluate transmission models based on their fit, researchers need to observe a wide range of sufficiently distant kinship correlations.⁴²

The Standard Genetic Model and *Height*. That the standard genetic model cannot fit the kinship pattern in educational advantages is not a mechanical consequence of the model having comparatively few parameters. To demonstrate this, we also calibrate the genetic model for *body height*. Because genes are known to be the primary source of variation in height, a genetic model should provide a reasonably good fit. We show in Section G.4 in the Online Appendix that this is the case, although a genetic model with phenotypic assortment cannot explain why the kinship correlations in height remain non-negligible for distant siblings-in-law.

5.2 Extended Model with Two Latent Factors

Although the objective of our study is not to decipher the elements that make up the latent variable z , it may be useful to try to quantify which part is composed of genetic

⁴²Most research to date has been based on even narrower set of kinship correlations than the 15 moments used in this example. Prior work may therefore not have had enough “power” to distinguish different transmission models based on their statistical properties. Ruby et al. (2018) make a similar point with respect to estimation of the heritability of human longevity.

factors and which is based on cultural or environmental factors. Thus, we now decompose the latent factor z_t^k into a genetic factor $z_t^{G,k}$, and a socio-cultural or “cultural” factor $z_t^{C,k}$, which captures all cultural and environmental factors that are transmitted but which are not genetic. The outcome y for an individual from generation t and gender k is given by

$$y_t^k = \beta^k \tilde{y}_{t-1}^k + z_t^{G,k} + z_t^{C,k} + x_t^k + u_t^k \quad (8)$$

We model the genetic factor following the standard model of genetic inheritance with assortative mating used in Quantitative Genetics (Crow and Felsenstein, 1968). The genetic factor of the child, $z_t^{G,k}$, depends on the father $z_{t-1}^{G,m}$ as well as on the mother $z_{t-1}^{G,f}$, as in equation (7). We do not need to impose the condition that is often assumed in quantitative genetics that the “environments” of parents and offspring are independent, since the latent variable $z_t^{C,k}$ captures such shared environment.⁴³ The cultural factor, $z_t^{C,k}$, depends on the father’s $z_{t-1}^{C,m}$ and the mother’s $z_{t-1}^{C,f}$, as z_t^k in our baseline model. The remaining elements are also defined analogously.

We assume assortative mating occurs in both schooling and the cultural factor, but there is no *direct* sorting in the genetic factor (i.e., the coefficients of $z_{t-1}^{G,m}$ in the linear projections of $z_{t-1}^{G,f}$, $z_{t-1}^{C,f}$ and y_{t-1}^f on $z_{t-1}^{G,m}$, $z_{t-1}^{C,m}$ and y_{t-1}^m are zero).⁴⁴ However, the spousal correlation in the genetic factor is not restricted to be zero. While our assumed structure of sorting is not the same, it shares similarities with recent work in genetics allowing for “secondary assortment” (Robinson et al., 2017), as we allow for matching in a non-genetic latent factor that is distinct from the genotype or phenotype.

While the model initially depends on the 15 correlations between the elements of the

⁴³We also allow for a possible correlation between the environments of siblings. In quantitative genetics it is common to assume that the covariance of the genetic contribution and the environment is zero. In our case, if we see $z_t^{C,k}$ as part of the environment, such covariance does not need to be zero; however, in our calibration, it turns out to be basically zero. Another difference is that we only consider an “additive” genetic component and leave out the “dominance” contribution. Thus, we estimate the so-called *weak heritability*. The dominance contribution, which is shared by siblings, would be picked up by our variable x (if of positive magnitude). The model does not allow for non-additive gene-environment interactions, a restriction shared by most classical heritability statistics (see Feldman and Ramachandran, 2018).

⁴⁴Rice, Cloninger and Reich (1978) and Cloninger, Rice and Reich (1979) used Wright’s work (Wright, 1921) on path analysis to develop a series of theoretical model very much related to our model here. In particular, they allow for assortative mating, gender differences and genetic and cultural transmission. As in our model, these authors assume that assortative mating does not occur directly in genes. Truett et al. (1994) and Eaves et al. (1999) apply those models on extended twin-family data. The main differences with our model are that they do not consider both types of assortative mating, do not allow for a direct effect of parent status on the child status, and most of the correlations involved some type of twin. Moreover, they study personality and social attitudes instead of socioeconomic outcomes, based on samples that are much smaller than the ones we consider here.

Table 5: Calibrated Parameters in Swedish Registers (Education, Two Factor Model)

<i>Panel A: Intergenerational Processes</i>								
β^m	β^f	γ^m	γ^f	σ_{ym}^2	σ_{yf}^2	σ_{zcm}^2	σ_{zcf}^2	σ_{zg}^2
0.116	0.100	0.690	0.587	4.648	4.465	1.753	1.347	0.316
α_{ym}	α_{yf}	α_{zm}	α_{zf}	σ_{um}^2	σ_{uf}^2			
0.448	0.003	0.577	0.659	2.058	2.319			
<i>Within-person correlations in y and z:</i>								
	ρ_{yzc}	ρ_{ygz}	ρ_{zczg}					
<i>male</i>	0.667	0.304	0.034					
<i>female</i>	0.594	0.304	0.034					
<i>Ancestor correlations in y and z:</i>								
	Father-Son	Fr.-Daughter	Mother-Son	Mother-Daughter				
<i>in zc</i>	0.576	0.580	0.533	0.507				
<i>in zg</i>	0.513	0.513	0.513	0.513				
<i>in zc+zg</i>	0.582	0.585	0.546	0.527				
	Father-Son	Grandfr.-Son	GGrandfr.-Son	GGrandfr.-Son				
<i>in y</i>	0.379	0.209	0.121	0.071				
<i>in zc+zg</i>	0.582	0.340	0.199	0.116				
<i>Panel B: Sibling Processes</i>								
	σ_{xm}^2	σ_{xf}^2	σ_{xmf}	σ_{em}^2	σ_{ef}^2	σ_{emef}		
	0.120	0.173	0.000	0.681	0.729	0.652		
<i>Sibling correlations in zc and zg:</i>								
	Brothers	Sisters	Mixed		Brothers	Sisters	Mixed	
<i>in zc</i>	0.754	0.898	0.785	<i>in zg</i>	0.513	0.513	0.513	
<i>Panel C: Assortative Processes</i>								
ρ_{ymyf}	ρ_{ymzf}	ρ_{ymzgf}	$\rho_{zcm yf}$	$\rho_{zcm zcf}$	$\rho_{zcm zgf}$	$\rho_{zgm yf}$	$\rho_{zgm zcf}$	$\rho_{zgm zgf}$
0.491	0.514	0.099	0.546	0.695	0.082	0.083	0.049	0.025
<i>Panel D: Variance Decomposition of y</i>								
	\tilde{y}_{t-1}	\tilde{z}_{t-1}^C	\tilde{z}_{t-1}^G	$\sigma_{\tilde{y}\tilde{z}}$	$\Sigma_{\tilde{y},\tilde{z}}$	x_t	e_t	$\Sigma_{\tilde{y},\tilde{z},x,e}$
<i>male</i>	1.0%	13.8%	3.5%	7.6%	25.9%	2.6%	14.6%	43.1%
<i>female</i>	1.0%	10.8%	3.6%	6.0%	21.4%	3.9%	16.3%	41.5%

Notes: Panels A and B report parameter estimates and implied ancestor and sibling correlations from calibration of the extended model with genetic and non-genetic latent factors (z^G and z^C). The parameters β and σ_y^2 capture the direct transmission and variance of y ; γ and σ_{zc}^2 the transmission and variance of z^C ; σ_{zg}^2 the variance of z^G ; and σ_x^2 and σ_e^2 shared sibling influences in y and z^C ; see equations (2)-(3) and (7)-(8) for details. Panel C reports the coefficients from the linear projections (4) and (5) of z^k and y^k for $k = f, m$ on their spouse's z and y and the implied spousal correlations. Panel D decomposes σ_y^2 into the components explained by the parents' y (\tilde{y}_{t-1}), z^C (\tilde{z}_{t-1}^C), z^G (\tilde{z}_{t-1}^G) and their covariances ($\sigma_{\tilde{y}\tilde{z}}$), and the sibling components in y (x_t) and z (e_t); $\Sigma_{\tilde{y},\tilde{z}}$ and $\Sigma_{\tilde{y},\tilde{z},x,e}$ are the total percentages explained by the parents and the close family (parental and shared sibling influences), respectively. Based on the kinship correlations reported in Table 3.

set $(z_{t-1}^{G,m}, z_{t-1}^{C,m}, y_{t-1}^m, z_{t-1}^{G,f}, z_{t-1}^{C,f}, y_{t-1}^f)$, we show in Online Appendix D that in steady state, there are only four free correlations, $\rho_{z^C,m,z^C,f}$, ρ_{z^C,m,y^f} , $\rho_{y^m,z^C,f}$ and ρ_{y^m,y^f} , as the remaining ones are functions of these four and the other parameters of the model. Then, the two-factor model has only one more parameter than the benchmark, the variance of the genetic factor $\sigma_{z^G}^2$, which is equal for both genders.

We calibrate this extended model using the 105 correlations of our baseline specification.⁴⁵

⁴⁵The fit is very good, which is not surprising, since the fit was already very good for our benchmark

The estimated parameters are presented in Table 5. The general picture is similar to the benchmark specification. Indirect transmission through the cultural factor is much more important than the direct transmission channel. The sibling correlation in the cultural factor is much bigger than in the observed outcome. Assortative mating takes place mainly in the cultural factor. Educational attainment is correlated between spouses because it is correlated with their respective “cultural” latent factor.

The interesting part of this exercise is to assess the relative contribution of the genetic and non-genetic factors to the variance in years of schooling.⁴⁶ We find that the cultural factor explains 38% of the variance of the observed outcome for males and 30% for females ($\sigma_{zck}^2/\sigma_{yk}^2$ for $k = m, f$), whereas the “heritability”, i.e. the share of the variance explained by genetic factors, is only 7% ($\sigma_{zg}^2/\sigma_{yk}^2$). This estimated heritability is slightly below recent evidence from genome-wide association studies (GWAS) based on direct genetic information. For instance, Lee and et al. (2018), using a sample of more than a million individuals, find that *polygenic scores* explain between 11 – 13% of the variance in years of schooling.⁴⁷ To address a potential upward bias from the correlation of polygenic scores with environmental factors, researchers use within-family designs that exploit random variation of actual around the expected genetic relatedness.⁴⁸ These estimates tend to be smaller, but much of the relationship between polygenic scores and educational attainment remains (Papageorge and Thom, 2018).

Estimates from GWA studies are much lower than those found in the behavioral genetics literature comparing different types of twins or adoptees (Björklund, Lindahl and Plug, 2006), which estimates that genes explain between 30 and 40% of the variance in years of schooling (Branigan, McCallum and Freese, 2013). This difference between the traditional twin-based estimates and the more direct evidence from GWA studies is sometimes called “*missing heritability*” (see Golan, Lander and Rosset, 2014). Some authors consider that

model. As in the benchmark case, the out-of-sample predictions are also good.

⁴⁶We measure the outcomes for biological parents, irrespectively of divorce or other changes in family structure. Our estimates therefore quantify the genetic and non-genetic influences of biological parents and might miss additional non-genetic contribution of non-biological parents.

⁴⁷Applied to the Health and Retirement Study, the same polygenic score explains between 4.5 – 9.7% of the variance in schooling (Papageorge and Thom, 2018). The predictive power of PGS increases with sample size, but Cesarini and Visscher (2017) argue that recent studies based on millions of observations (such as Lee and et al., 2018) come close to the theoretical upper bound of the approach.

⁴⁸Estimates from GWA studies capture only additive effects of certain single-nucleotide polymorphisms, and might therefore represent a lower bound of the genetic contribution (Selzam et al. 2017). On the other hand, they may be biased upward by the correlation of polygenic scores with environmental factors (Domingue et al., 2018). The distinction between environmental and genetic factors may not be sharp. For example, environmental factors may itself be partly determined by the genetic endowments of the parents (“*genetic nurture*”, Kong et al. 2018).

those high values are a consequence of the variance analysis used and the lack of a correct recognition of a non-genetic transmission of many cultural traits in twin studies.⁴⁹ Thus, [Feldman and Ramachandran \(2018\)](#) claim that the results obtained from twins studies are not the standards relative to which other variance analyses should be compared.

In particular, the twin approach is sensitive to assumptions on the degree of assortative mating, which cannot be well estimated in traditional data with only close kins. [Ruby et al. \(2018\)](#) illustrate this point by using large-scale ancestry information from the *Ancestry.com* repository to estimate the heritability of human longevity. While their estimates based on close genetic relatives agree with the prior literature, estimates based on more distant relatives suggest that assortative mating in longevity is much stronger, and its heritability therefore much weaker. By linking distant kins in administrative data, we can gain similar insights for socioeconomic outcomes that are of more direct interest in the social sciences. It is also interesting that we find a close to zero correlation between the latent genetic and cultural factors ($\rho_{z^C z^G} = 0.03$). If we see the cultural factor as part of the socioeconomic environment provided by parents, our findings are in accordance with [Papageorge and Thom \(2018\)](#), who show that the relationship between polygenic scores and the socioeconomic status of the family is also very small. Another interesting result is the low degree of assortative mating in the genetic factor that we find, $\rho_{z^G, m_{z^G, f}} = 0.025$, which is also consistent with estimates from recent GWA studies, like [Robinson et al. \(2017\)](#) who find a degree of genetic assortment between 0% and 6% or [Domingue et al. \(2014\)](#) whose estimates vary between 2% and 4.5%.

Splitting the unobservable factor into genetic and non-genetic components has no consequences for the implied long-run correlations. The correlations with grandparents, great-grand-parents and great-great-grandparents in education or the total latent factor ($z_t^k = z_t^{G, k} + z_t^{C, k}$) are nearly identical to those obtained from the benchmark model. This observation relates to the argument that distant vertical correlations are not informative about the relative contribution of genetic and non-genetic pathways to status persistence – their transmission patterns are statistically too similar to be distinguishable from a vertical perspective alone. Instead, they are very distinct in the horizontal dimension.

⁴⁹Twin studies are subject to a number of conceptual issues, including that (i) gene-environment interactions are not captured by the linear model used, (ii) the overall effect of genes may not add up linearly (e.g., dominance of alleles or epistasis, dominance of genes), (iii) the environment may be different for twins or adoptees than for other sibling types ([Goldberger, 1979](#)), and (iv) there might be less variability in the phenotype among families with twins or adoptees.

6 Conclusions

We have proposed a new approach to estimate intergenerational mobility and assortative mating. While sharing conceptual similarities with prior work on the *correlation between relatives* in quantitative genetics and economics (e.g., [Behrman and Taubman, 1989](#)), it deviates in two key aspects. First, our primary interest is in the overall extent to which advantages are transmitted from one generation to the next, less in the nature-nurture debate at the heart of prior work. We thus do not need to deal with the complicated relation between genes and environment ([Goldberger, 1979](#)), and instead capture both. Second, we exploit administrative registers to chain-link “horizontal” relatives, such as distant siblings-in-law. This horizontal approach has many advantages compared to the conventional “vertical” approach. It does not require the observation of distant ancestors, and socioeconomic outcomes can be measured within a single data source, at approximately the same age and time. Most importantly, the horizontal yields many more kinship moments than the vertical approach.

Consequently, we can characterize the transmission of socioeconomic inequalities in more detail than what has been possible previously. In particular, we account for latent pathways in each of the intergenerational, sibling and assortative components of the transmission process, motivated by recent multigenerational studies (e.g., [Clark 2014](#), [Lindahl et al. 2015](#)). We find strong persistence not only in the intergenerational, but also in the sibling and assortative processes. Conventional measures based on observable characteristics greatly understate the extent to which latent advantages correlate between kins. For example, sibling correlations (known to be a comparatively comprehensive measure of family background; [Jäntti and Jenkins, 2014](#)), still understate – by about 50% – the similarity of siblings in latent advantages that determine the socioeconomic prospects of their descendants.

Most striking is the degree of assortative matching that our data imply. Combined with large-scale administrative data, our approach allows us to track distant siblings-in-law. Because they are separated by many spousal links, it becomes quite apparent if a model cannot fit the assortative process in latent or observable characteristics. Our data suggests an extremely high degree of assortative matching, even in a country as egalitarian as Sweden, with the spousal correlation in latent advantages estimated to be around 0.75 – implying far greater sorting between spouses than indicated by previous studies.

The observation of both consanguine (“blood”) and distant affine (“in-law”) relatives allowed us to also contribute to the nature vs. nurture debate, distinguishing the role of genetic and non-genetic mechanisms in the second part of our paper. We show that a standard genetic model cannot fit the kinship pattern in educational advantages. The observation of a large set of kinship moments is key for this conclusion. The genetic model *appears* to explain the transmission process well when considering a small set of vertical moments, but fails to explain the remarkable similarity of distant siblings-in-law.

Genetic and non-genetic pathways are difficult to distinguish because they can generate a similar statistical pattern in the intergenerational dimension. In contrast, their assortative pattern turns out to be very distinct. The horizontal approach can, therefore, be used to decompose genetic from non-genetic mechanisms. Calibrating an extended two-factor model, we show that genetic and non-genetic latent factors are transmitted at a similar rate, with about 7% of the variation in years of schooling being explained by variation in latent genetic factors. However, the similarity of spouses is nearly exclusively due to non-genetic factors. Remarkably, our estimates of the heritability of education are in line with recent findings from behavioral genetics, even though our approach is very different.

Our study illustrates the potential of linking horizontal kins in administrative registers. However, our implementation is subject to some limitations. One problem for the estimation of distributional models is that the moments may not be in a steady-state equilibrium (Atkinson and Jenkins 1984). Because horizontal kins can be observed at a similar time, our approach is arguably less sensitive to this issue than a vertical approach based on distant ancestors. Still, consideration of the off-steady state dynamics would be useful. Another limitation is that we do not model fertility. Again this is standard in the literature, but it might be a concern here because the existence of a sibling-in-law depends on the existence of a sibling – skewing the sample towards larger families with lower socioeconomic status. This bias appears small in our setting, but an explicit consideration of fertility could be fruitful for future work. Finally, one might ask whether non-linearities in the transmission process, such as heterogeneity across families (Bingley and Cappellari, 2019), might contribute to the correlation pattern between distant kins.

The aggregate statistics and program codes underlying this article are available in Zenodo, at <https://doi.org/10.5281/zenodo.6840611>.

References

- Abowd, John M., and David Card.** 1989. "On the Covariance Structure of Earnings and Hours Changes." *Econometrica*, 57(2): 411–445.
- Adermon, Adrian, Mikael Lindahl, and Daniel Waldenström.** 2018. "Intergenerational Wealth Mobility and the Role of Inheritance: Evidence from Multiple Generations." *The Economic Journal*, 128(612): F482–F513.
- Adermon, Adrian, Mikael Lindahl, and Mårten Palme.** 2021. "Dynastic Human Capital, Inequality, and Intergenerational Mobility." *American Economic Review*, 111(5): 1523–48.
- Anderson, Lewis R., Paula Sheppard, and Christiaan W. S. Monden.** 2018. "Grandparent Effects on Educational Outcomes: A Systematic Review." *Sociological Science*.
- Atkinson, Anthony B., and Stephen P. Jenkins.** 1984. "The Steady-State Assumption and the Estimation of Distributional and Related Models." *Journal of Human Resources*, 19(3): 358–376.
- Barone, Guglielmo, and Sauro Mocetti.** 2020. "Intergenerational Mobility in the Very Long Run: Florence 1427-2011." *Review of Economic Studies*.
- Becker, Gary S., and Nigel Tomes.** 1979. "An Equilibrium Theory of the Distribution of Income and Intergenerational Mobility." *Journal of Political Economy*, 87(6): 1153–1189.
- Becker, Gary S., and Nigel Tomes.** 1986. "Human Capital and the Rise and Fall of Families." *Journal of Labor Economics*, 4(3): 1–39.
- Behrman, Jere R., and Paul Taubman.** 1989. "Is Schooling "Mostly in the Genes"? Nature-Nurture Decomposition Using Data on Relatives." *Journal of Political Economy*, 97(6): 1425–1446.
- Bingley, Paul, and Lorenzo Cappellari.** 2019. "Correlation of Brothers' Earnings and Intergenerational Transmission." *Review of Economics and Statistics*, 101(2): 370–383.
- Björklund, Anders, and Kjell G. Salvanes.** 2011. "Education and Family Background: Mechanisms and Policies." In *Handbook of the Economics of Education*. Vol. 3, ed. Eric A. Hanushek, Stephen Machin and Ludger Woessmann, 201–247. Elsevier.
- Björklund, Anders, and Markus Jäntti.** 2019. "Intergenerational Mobility, Intergenerational Effects, Sibling Correlations, and Equality of Opportunity: a Comparison of Four Approaches." DIAL Working Paper Series 17/2019.
- Björklund, Anders, Markus Jäntti, and Gary Solon.** 2005. "Influences of Nature and Nurture on Earnings Variation." In *Unequal Chances. Family Background and Economic Success.*, ed. S. Bowles, H. Gintis and M. O. Groves. Princeton University Press.
- Björklund, Anders, Markus Jäntti, and Matthew Lindquist.** 2009. "Family Background and Income During the Rise of the Welfare State: Brother Correlations in Income for Swedish Men born 1932-1968." *Journal of Public Economics*, 93(5-6): 671–680.
- Björklund, Anders, Mikael Lindahl, and Erik Plug.** 2006. "The Origins of Intergenerational Associations: Lessons from Swedish Adoption Data." *Quarterly Journal of Economics*, 121(3): 999–1029.
- Blundell, Jack, and Erling Risa.** 2018. "Intergenerational Mobility as a Prediction Problem." mimeo.
- Branigan, Amelia R., Kenneth J McCallum, and Jeremy Freese.** 2013. "Variation

- in the Heritability of Educational Attainment: An International Meta-analysis.” *Social forces*, 92(1): 109–140.
- Braun, Sebastian Till, and Jan Stuhler.** 2018. “The Transmission of Inequality Across Multiple Generations: Testing Recent Theories with Evidence from Germany.” *The Economic Journal*, 128(609): 576–611.
- Cavalli-Sforza, Luigi Luca, and Marcus W Feldman.** 1981. *Cultural Transmission and Evolution: A Quantitative Approach*. Princeton University Press.
- Cesarini, David, and Peter M. Visscher.** 2017. “Genetics and Educational Attainment.” *npj Science of Learning*, 2(1): 4.
- Chetty, Raj, Nathaniel Hendren, Patrick Kline, and Emmanuel Saez.** 2014. “Where is the Land of Opportunity? The Geography of Intergenerational Mobility in the United States.” *Quarterly Journal of Economics*, 129(4): 1553–1623.
- Clark, Gregory.** 2014. *The Son Also Rises: Surnames and the History of Social Mobility*. Princeton University Press.
- Clark, Gregory.** 2021. “For Whom the Bell Curve Tolls: A Lineage of 400,000 Individuals 1750-2020 shows Genetics Determines most Social Outcomes.” mimeo.
- Clark, Gregory, and Daniel Diaz-Vidal.** 2015. “How Strong is Assortative Mating? A Surname Analysis.” Working Paper.
- Clark, Gregory, Neil Cummins, Yu Hao, and Dan Diaz Vidal.** 2015. “Surnames: A New Source for the History of Social Mobility.” *Explorations in Economic History*, 55: 3–24.
- Cloninger, C Robert, John Rice, and Theodore Reich.** 1979. “Multifactorial Inheritance with Cultural Transmission and Assortative Mating. II. A General Model of Combined Polygenic and Cultural Inheritance.” *American Journal of Human Genetics*, 31(2): 176.
- Colagrossi, Marco, Béatrice d’Hombres, and Sylke V. Schnepf.** 2019. “Like (Grand)Parent, Like Child? Multigenerational Mobility Across the EU.” Institute for the Study of Labor IZA Discussion Papers 12302.
- Colagrossi, Marco, Claudio Deiana, Andrea Geraci, Ludovica Giua, and Gianluca Mazzarella.** 2020. “Two Generations of Siblings and Cousins Correlations Across the Ancestors’ Wealth Distribution.” mimeo.
- Corak, Miles.** 2013. “Income Inequality, Equality of Opportunity, and Intergenerational Mobility.” *Journal of Economic Perspectives*, 27(3): 79–102.
- Crow, James F., and Joseph Felsenstein.** 1968. “The Effect of Assortative Mating on the Genetic Composition of a Population.” *Eugenics Quarterly*, 15(2): 85–97.
- Domingue, Benjamin W., Daniel W. Belsky, Jason M. Fletcher, Dalton Conley, Jason D. Boardman, and Kathleen Mullan Harris.** 2018. “The Social Genome of Friends and Schoolmates in the National Longitudinal Study of Adolescent to Adult Health.” *Proceedings of the National Academy of Sciences*, 115(4): 702–707.
- Domingue, Benjamin W., Jason Fletcher, Dalton Conley, and Jason D. Boardman.** 2014. “Genetic and Educational Assortative Mating Among US Adults.” *Proceedings of the National Academy of Sciences*.
- Donner, Allan.** 1986. “A Review of Inference Procedures for the Intraclass Correlation Coefficient in the One-Way Random Effects Model.” *International Statistical Review*, 54(1).
- Dribe, Martin, and Jonas Helgertz.** 2016. “The Lasting Impact of Grandfathers:

- Class, Occupational Status, and Earnings over Three Generations in Sweden 1815–2011.” *The Journal of Economic History*, 76(4): 969–1000.
- Eaves, Lindon, Andrew Heath, Nicholas Martin, Hermine Maes, Michael Neale, Kenneth Kendler, Katherine Kirk, and Linda Corey.** 1999. “Comparing the Biological and Cultural Inheritance of Personality and Social Attitudes in the Virginia 30 000 Study of Twins and Their Relatives.” *Twin Research and Human Genetics*, 2(2): 62–80.
- Engzell, Per, Carina Mood, and Jan O. Jonsson.** 2019. “Putting the Grandparents to Rest: False Positives in Multigenerational Mobility Research.” mimeo.
- Ermisch, John, Marco Francesconi, and Thomas Siedler.** 2006. “Intergenerational Mobility and Marital Sorting.” *The Economic Journal*, 116(513): 659–679.
- Feldman, Marcus W, and Sohini Ramachandran.** 2018. “Missing Compared to What? Revisiting Heritability, Genes and Culture.” *Philosophical Transactions of the Royal Society B: Biological Sciences*, 373(1743): 20170064.
- Fernández, Raquel, and Richard Rogerson.** 2001. “Sorting and Long-Run Inequality.” *The Quarterly Journal of Economics*, 116(4): 1305–1341.
- Golan, David, Eric S. Lander, and Saharon Rosset.** 2014. “Measuring Missing Heritability: Inferring the Contribution of Common Variants.” *Proceedings of the National Academy of Sciences*, 111(49): E5272–E5281.
- Goldberger, Arthur S.** 1979. “Heritability.” *Economica*, 46(184): pp. 327–347.
- Goldthorpe, John H.** 2014. “The Role of Education in Intergenerational Social Mobility: Problems from Empirical Research in Sociology and Some Theoretical Pointers from Economics.” *Rationality and Society*, 26(3): 265–289.
- Güell, Maia, José V. Rodríguez Mora, and Gary Solon.** 2018. “New Directions in Measuring Intergenerational Mobility: Introduction.” *The Economic Journal*.
- Hällsten, Martin.** 2014. “Inequality Across Three and Four Generations in Egalitarian Sweden: 1st and 2nd Cousin Correlations in Socio-economic Outcomes.” *Research in Social Stratification and Mobility*, 35: 19–33.
- Hällsten, Martin, and Martin Kolk.** 2020. “The Shadow of Peasant Past: Seven Generations of Inequality Persistence in Northern Sweden.” Stockholm University.
- Holmlund, Helena.** 2022. “How Much Does Marital Sorting Contribute to Intergenerational Socioeconomic Persistence?” *Journal of Human Resources*, 57(2): 372–399.
- Holmlund, Helena, Mikael Lindahl, and Erik Plug.** 2011. “The Causal Effect of Parents’ Schooling on Children’s Schooling: A Comparison of Estimation Methods.” *Journal of Economic Literature*, 49(3): 615–51.
- Hufe, Paul, Andreas Peichl, John Roemer, and Martin Ungerer.** 2017. “Inequality of Income Acquisition: The Role of Childhood Circumstances.” *Social Choice and Welfare*, 49(3-4): 499–544.
- INE.** 2001. “Censos de Población y Viviendas 2001.” Instituto Nacional de Estadística.
- Jäntti, Markus, and Stephen Jenkins.** 2014. “Income Mobility.” In *Handbook of Income Distribution*. Vol. 2, , ed. Anthony Atkinson and François Bourguignon. Elsevier.
- Kong, Augustine, Gudmar Thorleifsson, Michael L. Frigge, Bjarni J. Vilhjalmsón, Alexander I. Young, Thorgeir Thorgeirsson ..., and Kari Stefansson.** 2018. “The Nature of Nurture: Effects of Parental Genotypes.” *Science*, 359(6374): 424–428.
- Lee, James J., and et al.** 2018. “Gene Discovery and Polygenic Prediction from a

- Genome-wide Association Study of Educational Attainment in 1.1 million Individuals.” *Nature Genetics*, 50(8): 1112–1121.
- Lindahl, Mikael, Mårten Palme, Sofia Sandgren Massih, and Anna Sjögren.** 2015. “Long-term Intergenerational Persistence of Human Capital: An Empirical Analysis of Four Generations.” *Journal of Human Resources*, 50(1): 1–33.
- Loeken, Katrine V., Magne Mogstad, and Matthew Wiswall.** 2012. “What Linear Estimators Miss: The Effects of Family Income on Child Outcomes.” *American Economic Journal: Applied Economics*, 4(2): 1–35.
- Long, Jason, and Joseph Ferrie.** 2018. “Grandfathers Matter (ed): Occupational Mobility Across Three Generations in the US and Britain, 1850–1911.” *The Economic Journal*, 128(612): F422–F445.
- Mare, Robert.** 2011. “A Multigenerational View of Inequality.” *Demography*, 48(1): 1–23.
- Neidhöfer, Guido, and Maximilian Stockhausen.** 2019. “Dynastic Inequality Compared: Multigenerational Mobility in the United States, the United Kingdom, and Germany.” *Review of Income and Wealth*, 65(2): 383–414.
- Nybom, Martin, and Jan Stuhler.** 2017. “Biases in Standard Measures of Intergenerational Income Dependence.” *Journal of Human Resources*, 52(3): 800–825.
- Okbay, Aysu, and et al.** 2016. “Genome-wide Association Study Identifies 74 Loci Associated with Educational Attainment.” *Nature*, 533: 539 EP –.
- Papageorge, Nicholas W, and Kevin Thom.** 2018. “Genes, Education, and Labor Market Outcomes: Evidence from the Health and Retirement Study.” NBER.
- Raaum, O., B. Bratsberg, K. Røed, E. Österbacka, T.V. Eriksson, M. Jäntti, and R. Naylor.** 2007. “Marital Sorting, Household Labor Supply, and Intergenerational Earnings Mobility across Countries.” *The B.E. Journal of Economic Analysis & Policy*, 7(2): Article 7.
- Rice, John, Robert C. Cloninger, and Theodore Reich.** 1978. “Multifactorial Inheritance with Cultural Transmission and Assortative Mating. I. Description and Basic Properties of the Unitary Models.” *American Journal of Human Genetics*, 30(6): 618.
- Robinson, Matthew R, Aaron Kleinman, Mariaelisa Graff, Anna AE Vinkhuyzen, David Couper, Michael B Miller, Wouter J Peyrot, Abdel Abdellaoui, Brendan P Zietsch, Ilja M Nolte, et al.** 2017. “Genetic evidence of assortative mating in humans.” *Nature Human Behaviour*, 1(1): 1–13.
- Roemer, John E, and Alain Trannoy.** 2016. “Equality of Opportunity: Theory and Measurement.” *Journal of Economic Literature*, 54(4): 1288–1332.
- Ruby, J. Graham, Kevin M. Wright, Kristin A. Rand, Amir Kermany, Keith Noto, Don Curtis, Neal Varner, Daniel Garrigan, Dmitri Slinkov, Ilya Dorfman, et al.** 2018. “Estimates of the Heritability of Human Longevity are Substantially Inflated Due to Assortative Mating.” *Genetics*, 210(3): 1109–1124.
- Selzam, Saskia, Eva Krapohl, Sophie von Stumm, PF O’reilly, K Rimfeld, Y Kovas, PS Dale, JJ Lee, and R Plomin.** 2017. “Predicting Educational Achievement From DNA.” *Molecular psychiatry*, 22(2): 267.
- Solon, Gary.** 2018. “What Do We Know So Far about Multigenerational Mobility?” *The Economic Journal*, 128(612): F340–F352.
- Statistics Sweden.** 2016. “Multi-Generation Register 2016. A Description of Contents and Quality.”

- Stuhler, Jan.** 2012. "Mobility Across Multiple Generations: The Iterated Regression Fallacy." Institute for the Study of Labor (IZA) IZA Discussion Papers 7072.
- Truett, K. R., L. J. Eaves, E. E. Walters, A. C. Heath, J. K. Hewitt, J. M. Meyer, J. Silberg, M. C. Neale, N. G. Martin, and K. S. Kendler.** 1994. "A Model System for Analysis of Family Resemblance in Extended Kinships of Twins." *Behavior Genetics*, 24(1): 35–49.
- Vosters, Kelly, and Martin Nybom.** 2017. "Intergenerational Persistence in Latent Socioeconomic Status: Evidence from Sweden and the United States." *Journal of Labor Economics*, 35(3): 869–901.
- Wright, Sewall.** 1921. "Correlation and Causation." *Journal of Agricultural Research*, 20(7): 557–585.

Online Appendix (for online publication)

Estimating Intergenerational and Assortative Processes in Extended Family Data

A	The General Model	1
A.1	Assortative mating process	1
A.2	Steady state assumption	2
A.3	Covariances	3
B	No Direct Effect and Assortative Mating Only in z	6
B.1	Correlations	6
B.2	Identification	7
C	The Genetic Model	10
C.1	Assortative mating process	10
C.2	Covariances	11
D	The General Model with Two Unobservable Factors	12
D.1	Assortative mating process	13
D.2	Steady state assumption	15
D.3	Main covariances	16
D.4	Other covariances	16
E	Robustness Checks	19
F	Cohort Selection and Age Differences	22
F.1	Cohort distribution	22
F.2	Cohort trends	24
F.3	The age differences between cousins	25
G	Additional Results: Swedish Registers	27
G.1	Relation to name-based estimates	27
G.2	The baseline model and income	28
G.3	The baseline model and height	32
G.4	The standard genetic model and height	34
H	Additional Results: Spanish Census	36
H.1	Data	36
H.2	Estimation results	38

A The General Model

We assume that the value of the outcome y for an individual from generation t is given by

$$y_t^k = \beta^k \tilde{y}_{t-1}^k + z_t^k + x_t^k + u_t^k \quad (\text{A.1})$$

where the superscript $k = m$ stands for males and $k = f$ for females. We assume that

$$\tilde{y}_{t-1}^k = \alpha_y^k y_{t-1}^m + (1 - \alpha_y^k) y_{t-1}^f$$

and the socioeconomic status of the child, z_t^k , depends on the father z_{t-1}^m as well as on the mother z_{t-1}^f

$$\begin{aligned} z_t^k &= \gamma^k \tilde{z}_{t-1}^k + e_t^k + v_t^k \\ \tilde{z}_{t-1}^k &= \alpha_z^k z_{t-1}^m + (1 - \alpha_z^k) z_{t-1}^f \end{aligned} \quad (\text{A.2})$$

Regarding the shocks, we assume that x_t^k and e_t^k are shared by all siblings of the same gender, can be correlated across siblings of different gender and are uncorrelated to each other and with the other variables (in particular with z_{t-1}^k and y_{t-1}^l , $l = m, f$). Finally u_t^k and v_t^k are white-noise errors.

We assume throughout the appendix that the economy is in the steady state, and therefore all the parameters and the moments of all the variables are time invariant. We provide more detailed versions of the following derivations in a document titled “*Additional Derivations*”, which is available on the authors’ webpages (or upon request).

A.1 Assortative mating process

We assume there is assortative mating both in years of schooling and in socioeconomic status (see Behrman and Rosenzweig, 2002, for a related model with assortative mating in two dimensions). In particular we consider the linear projections of z_{t-1}^f and y_{t-1}^f on z_{t-1}^m and y_{t-1}^m :

$$\begin{aligned} z_{t-1}^f &= r_{zz}^m z_{t-1}^m + r_{zy}^m y_{t-1}^m + w_{t-1}^m \\ y_{t-1}^f &= r_{yz}^m z_{t-1}^m + r_{yy}^m y_{t-1}^m + \varepsilon_{t-1}^m \end{aligned}$$

where w_{t-1}^m and ε_{t-1}^m might be correlated but are uncorrelated with z_{t-1}^m and y_{t-1}^m .

The coefficients of the linear projections depend on the correlations $\rho_{z^m y^m}$, $\rho_{z^m z^f}$, $\rho_{z^m y^f}$, $\rho_{y^m z^f}$ and $\rho_{y^m y^f}$, as well as on the standard deviations of z_{t-1}^k and y_{t-1}^k , $k = m, f$:

$$\begin{aligned} r_{zz}^m &= \frac{1}{(1 - \rho_{z^m y^m}^2)} \frac{\sigma_{z^f}}{\sigma_{z^m}} (\rho_{z^m z^f} - \rho_{z^m y^m} \rho_{y^m z^f}) \\ r_{zy}^m &= \frac{1}{(1 - \rho_{z^m y^m}^2)} \frac{\sigma_{z^f}}{\sigma_{y^m}} (\rho_{y^m z^f} - \rho_{z^m y^m} \rho_{z^m z^f}) \end{aligned}$$

$$r_{yz}^m = \frac{1}{(1 - \rho_{z^m y^m}^2)} \frac{\sigma_{y^f}}{\sigma_{z^m}} (\rho_{z^m y^f} - \rho_{z^m y^m} \rho_{y^m y^f})$$

$$r_{yy}^m = \frac{1}{(1 - \rho_{z^m y^m}^2)} \frac{\sigma_{y^f}}{\sigma_{y^m}} (\rho_{y^m y^f} - \rho_{z^m y^m} \rho_{z^m y^f})$$

We use these matching functions to write years of schooling, y_t^k , and social status, z_t^k , as a function of father's years of schooling, y_{t-1}^m , and social status z_{t-1}^m . We can write (A.2) as

$$z_t^k = G_{zm}^k z_{t-1}^m + G_{ym}^k y_{t-1}^m + g_m^k \omega_{t-1}^m + e_t^k + v_t^k$$

where

$$G_{zm}^k = \gamma^k (\alpha_z^k + (1 - \alpha_z^k) r_{zz}^m)$$

$$G_{ym}^k = \gamma^k (1 - \alpha_z^k) r_{zy}^m$$

$$g_m^k = \gamma^k (1 - \alpha_z^k)$$

and (A.1) as

$$y_t^k = B_{ym}^k y_{t-1}^m + B_{zm}^k z_{t-1}^m + b_m^k \varepsilon_{t-1}^m + g_m^k \omega_{t-1}^m + e_t^k + v_t^k + x_t^k + u_t^k$$

where

$$B_{ym}^k = \beta^k (\alpha_y^k + (1 - \alpha_y^k) r_{yy}^m) + G_{ym}^k$$

$$B_{zm}^k = \beta^k (1 - \alpha_y^k) r_{yz}^m + G_{zm}^k$$

$$b_m^k = \beta^k (1 - \alpha_y^k)$$

All these expressions will be used to compute correlations between relatives that are related through their fathers. However, when we consider relatives that are related through their mothers, we need to find expressions for y_t^k and z_t^k as functions of mother's years of schooling, y_{t-1}^f , and social status z_{t-1}^f . These expressions are provided in a document titled “*Additional Derivations*” available on the authors' webpages (or upon request).

A.2 Steady state assumption

As mentioned above, we assume that the second order moments of all variables are time invariant. This steady state assumption implies that $\rho_{z^m y^m}$ and $\rho_{z^f y^f}$ depend on the remaining parameters of the model through the following equations:

$$(1 - \beta^m \alpha_y^m \gamma^m \alpha_z^m) \rho_{z^m y^m} - \beta^m (1 - \alpha_y^m) \gamma^m (1 - \alpha_z^m) \frac{\sigma_{z^f}}{\sigma_{z^m}} \frac{\sigma_{y^f}}{\sigma_{y^m}} \rho_{z^f y^f}$$

$$= \frac{\sigma_{z^m}}{\sigma_{y^m}} + \beta^m \alpha_y^m \gamma^m (1 - \alpha_z^m) \frac{\sigma_{z^f}}{\sigma_{z^m}} \rho_{y^m z^f} + \beta^m (1 - \alpha_y^m) \gamma^m \alpha_z^m \frac{\sigma_{y^f}}{\sigma_{y^m}} \rho_{z^m y^f}$$

$$\begin{aligned}
& -\beta^f(1-\alpha_y^f)\gamma^f(1-\alpha_z^f)\frac{\sigma_{z^m}}{\sigma_{z^f}}\frac{\sigma_{y^m}}{\sigma_{y^f}}\rho_{z^m y^m} + (1-\beta^f\alpha_y^f\gamma^f\alpha_z^f)\rho_{z^f y^f} \\
= & \frac{\sigma_{z^f}}{\sigma_{y^f}} + \beta^f\alpha_y^f\gamma^f(1-\alpha_z^f)\frac{\sigma_{z^m}}{\sigma_{z^f}}\rho_{z^m y^f} + \beta^f(1-\alpha_y^f)\gamma^f\alpha_z^f\frac{\sigma_{y^m}}{\sigma_{y^f}}\rho_{y^m z^f}
\end{aligned}$$

We then have that the model has 20 parameters $\gamma^k, \beta^k, \alpha_z^k, \alpha_y^k, \sigma_{z^k}^2, \sigma_{x^k}^2, \sigma_{e^k}^2$, $k = m, f$, and $\sigma_{x^m x^f}, \sigma_{e^m e^f}, \rho_{z^m z^f}, \rho_{y^m z^f}, \rho_{z^m y^f}$ and $\rho_{y^m y^f}$.

A.3 Covariances

A.3.1 Main covariances

We use the notation in Figure 1 to denote individuals with different degrees of kinship. We first compute the main covariances (husband-wife, parent-child and siblings). Then, the covariances for other relatives are obtained recursively.

Husband and wife $a - a'$

We have to compute the covariance between " a " and " a' ". Let $n = m, f$ be the gender of a and $n' = m, f$ the gender of the a' .

$$Cov(y_{t-1}^{a,n}, y_{t-1}^{a',n'}) = \sigma_{y^m}\sigma_{y^f}\rho_{y^m y^f}$$

Parent-child $aa - a'$

We have to compute the covariances between " aa " and " a' ". Let $n' = m, f$ be the gender of a' and $n^* = m, f$ the gender of the aa . We project aa on a' (his/her father or mother) who has gender n'

$$Cov(y_t^{aa,n^*}, y_{t-1}^{a',n'}) = B_{y^{n'}\sigma_{y^{n'}}^2} + B_{z^{n'}\sigma_{z^{n'}}\sigma_{y^{n'}}}\rho_{z^{n'}y^{n'}}$$

Siblings $a' - b$

We have to compute the covariances between " a' " and " b ". Let $n' = m, f$ be the gender of a' and $l = m, f$ the gender of the b . We project a' and b on their father or mother $GP2$ who has gender k

$$\begin{aligned}
Cov(y_{t-1}^{a',n'}, y_{t-1}^{b,l}) = & B_{y^k}^{n'}B_{y^k}^l\sigma_{y^k}^2 + B_{z^k}^{n'}B_{z^k}^l\sigma_{z^k}^2 + \left(B_{y^k}^{n'}B_{z^k}^l + B_{z^k}^{n'}B_{y^k}^l\right)\sigma_{z^{n'}}\sigma_{y^{n'}}\rho_{z^{n'}y^{n'}} + g_k^{n'}g_k^l\sigma_{w^k}^2 + b_k^{n'}b_k^l\sigma_{\varepsilon^k}^2 + \sigma_{e^{n'}e^l} \\
& + \left(b_k^{n'}g_k^l + g_k^{n'}b_k^l\right)Cov(\varepsilon_{t-1}^{n'}, \omega_{t-1}^{n'}) + \sigma_{x^{n'}x^l}
\end{aligned}$$

A.3.2 Other covariances

Before we obtain the remaining covariances for different degrees of kinship we compute the linear projections of $z_{t-1}^{a',n'}$ and $y_{t-1}^{a',n'}$ on $z_{t-1}^{b,l}$ and $y_{t-1}^{b,l}$, $n', l = m, f$, where a' and b are siblings

$$\begin{aligned}
z_{t-1}^{a',n'} &= r_{zz}^{n',l}z_{t-1}^{b,l} + r_{zy}^{n',l}y_{t-1}^{b,l} + w_{t-1}^{b,l} \\
y_{t-1}^{a',n'} &= r_{yz}^{n',l}z_{t-1}^{b,l} + r_{yy}^{n',l}y_{t-1}^{b,l} + \varepsilon_{t-1}^{b,l}
\end{aligned}$$

where $w_{t-1}^{b,l}$ and $\varepsilon_{t-1}^{b,l}$ might be correlated but are uncorrelated with $z_{t-1}^{b,l}$ and $y_{t-1}^{b,l}$ and

$$\begin{aligned} r_{zz}^{n',l} &= \frac{1}{\sigma_{z'l}^2 \sigma_{y^l}^2 - \sigma_{z^l y^l}^2} \left(\sigma_{y^l}^2 \sigma_{z^{a'}, n' z^b, l} - \sigma_{z^l y^l} \sigma_{z^{a'}, n' y^b, l} \right) \\ r_{zy}^{n',l} &= \frac{1}{\sigma_{z'l}^2 \sigma_{y^l}^2 - \sigma_{z^l y^l}^2} \left(\sigma_{z^l}^2 \sigma_{z^{a'}, n' y^b, l} - \sigma_{z^l y^l} \sigma_{z^{a'}, n' z^b, l} \right) \\ r_{yz}^{n',l} &= \frac{1}{\sigma_{z'l}^2 \sigma_{y^l}^2 - \sigma_{z^l y^l}^2} \left(\sigma_{y^l}^2 \sigma_{y^{a'}, n' z^b, l} - \sigma_{z^l y^l} \sigma_{y^{a'}, n' y^b, l} \right) \\ r_{yy}^{n',l} &= \frac{1}{\sigma_{z'l}^2 \sigma_{y^l}^2 - \sigma_{z^l y^l}^2} \left(\sigma_{z^l}^2 \sigma_{y^{a'}, n' y^b, l} - \sigma_{z^l y^l} \sigma_{y^{a'}, n' z^b, l} \right) \end{aligned}$$

Notice that error terms, $w_{t-1}^{b,l}$ and $\varepsilon_{t-1}^{b,l}$, are likely to be correlated with the latent factor and the outcome of a , the spouse of a' , and also with error terms of the linear projections of a' on a . However, since we use these linear projections to find the correlation with in-law relatives of b , what is relevant is whether $w_{t-1}^{b,l}$ and $\varepsilon_{t-1}^{b,l}$ are correlated with $z_{t-1}^{b',l}$ and $y_{t-1}^{b',l}$, where b' is the spouse of b . Since these error terms are not correlated with $z_{t-1}^{b,l}$ and $y_{t-1}^{b,l}$, and we are assuming that the assortative mating is in z and y , they are not correlated with $z_{t-1}^{b',l}$ and $y_{t-1}^{b',l}$ either.

Consanguine relatives ("blood")

Vertical covariances

Uncle/aunt (siblings of the parents) $aa - b$

We have to compute the covariances between " aa " and " b ". Let $n^* = m, f$ be the gender of aa and $l = m, f$ the gender of the b . We project aa on a' (his/her father or mother) who has gender n'

$$Cov(y_t^{aa, n^*}, y_{t-1}^{b, l}) = B_t^{n^*} Cov(z_{t-1}^{a', n'}, y_{t-1}^{b, l}) + B_{y_n}^{n^*} Cov(y_{t-1}^{a', n'}, y_{t-1}^{b, l})$$

where a' and b are siblings.

Horizontal covariances

Cousins $aa - bb$

We have to compute the covariances between " aa " and " bb ". Let $n^* = m, f$ be the gender of aa and $l^* = m, f$ the gender of the bb . We project bb on b (his/her father or mother) who has gender l

$$Cov(y_t^{aa, n^*}, y_t^{bb, l^*}) = B_{z_l}^{l^*} Cov(y_t^{aa, n^*}, z_{t-1}^{b, l}) + B_{y_l}^{l^*} Cov(y_t^{aa, n^*}, y_{t-1}^{b, l})$$

where b is the uncle/aunt of aa .

Affinity relatives ("in-law")

Vertical covariances

Spouse of the uncle/aunt (spouses of the siblings of the parents) $aa - b'$

We have to compute the covariances between " aa " and " b' ". Let $n^* = m, f$ be the gender of aa and $l' = m, f$ the gender of the b' . We project b' on his/her spouse b who has gender l

$$Cov(y_t^{aa, n^*}, y_{t-1}^{b', l'}) = r_{yz}^l Cov(y_t^{aa, n^*}, z_{t-1}^{b, l}) + r_{yy}^l Cov(y_t^{aa, n^*}, y_{t-1}^{b, l})$$

where b is uncle/aunt of aa .

Siblings of the siblings in law of the parents $aa - c$

We have to compute the covariances between " aa " and " c ". Let $n^* = m, f$ be the gender of aa and $o = m, f$ the gender of the c . We project c on his/her sibling b' who has gender l'

$$Cov(y_t^{aa, n^*}, y_{t-1}^{c, o}) = r_{yz}^{o, l'} Cov(y_t^{aa, n^*}, z_{t-1}^{b', l'}) + r_{yy}^{o, l'} Cov(y_t^{aa, n^*}, y_{t-1}^{b', l'})$$

where b' is the spouse of the uncle/aunt of aa . We can recursively compute the covariances for the spouses of the siblings in law of the parents and the siblings of the siblings in law of the parents of any degree.

Horizontal covariances

Siblings in law $a - b$

We have to compute the covariances between " a " and " b ". Let $n = m, f$ be the gender of a and $l = m, f$ the gender of the b . We project a on his/her spouse a' who has gender n'

$$Cov(y_{t-1}^{a, n}, y_{t-1}^{b, l}) = r_{yz}^{n'} Cov(z_{t-1}^{a', n'}, y_{t-1}^{b, l}) + r_{yy}^{n'} Cov(y_{t-1}^{a', n'}, y_{t-1}^{b, l})$$

where a' and b are siblings.

Spouse of the siblings in law $a - b'$

We have to compute the covariances between " a " and " b' ". Let $n = m, f$ be the gender of a and $l' = m, f$ the gender of the b' . We project b' on his/her spouse b who has gender l

$$Cov(y_{t-1}^{a, n}, y_{t-1}^{b', l'}) = r_{yz}^l Cov(y_{t-1}^{a, n}, z_{t-1}^{b, l}) + r_{yy}^l Cov(y_{t-1}^{a, n}, y_{t-1}^{b, l})$$

where a and b are siblings in law.

Sibling of the sibling in law $a' - c$

We have to compute the covariances between " a' " and " c ". Let $n' = m, f$ be the gender of a' and $o = m, f$ the gender of the c . We project a' on his/her sibling b who has gender l

$$Cov(y_{t-1}^{a', n'}, y_{t-1}^{c, o}) = r_{yz}^{n', l} Cov(z_{t-1}^{b, l}, y_{t-1}^{c, o}) + r_{yy}^{n', l} Cov(y_{t-1}^{b, l}, y_{t-1}^{c, o})$$

where b and c are siblings in law. We can recursively compute the covariances for siblings in law, spouses of the siblings in law and siblings of the siblings in law of any degree.

Cousins in law $aa - cc$

We have to compute the covariances between "aa" and "cc". Let $n^* = m, f$ be the gender of aa and $o^* = m, f$ the gender of the cc . We project cc on c (his/her father or mother) who has gender o

$$Cov(y_t^{aa, n^*}, y_t^{cc, o^*}) = B_{zo}^{o^*} Cov(y_t^{aa, n^*}, z_{t-1}^{c, o}) + B_{yo}^{o^*} Cov(y_t^{aa, n^*}, y_{t-1}^{c, o})$$

where c is the sibling of the sibling in law of the father/mother of aa . We can recursively compute the covariances for cousins in law of any degree.

B No Direct Effect and Assortative Mating Only in z

We next consider a latent factor model with no direct effect ($\beta = 0$) and assortative mating only in z (i.e. we assume that the coefficients of y_{t-1}^m in the linear projections of z_{t-1}^f and y_{t-1}^f on z_{t-1}^m and y_{t-1}^m are zero). This model is less general than the previous one but it has the advantage that we can show how the parameters are identified. Imposing these restrictions in the General Model, we find that outcome y_t^k and the latent factor z_t^k for an individual from generation t can be written as

$$\begin{aligned} y_t^k &= G_{zm}^k z_{t-1}^m + g_m^k \omega_{t-1}^m + e_t^k + x_t^k + v_t^k + u_t^k \\ z_t^k &= G_{zm}^k z_{t-1}^m + g_m^k \omega_{t-1}^m + e_t^k + v_t^k \end{aligned}$$

where

$$\begin{aligned} G_{zm}^k &= \gamma^k (\alpha_z^k + (1 - \alpha_z^k) \frac{\sigma_{zf}}{\sigma_{zm}} \rho_{zm, zf}) \\ g_m^k &= \gamma^k (1 - \alpha_z^k) \end{aligned}$$

All these expressions will be used to compute correlations between relatives that are related through their fathers. However, when we consider relatives that are related through their mothers, we need to find expressions for y_t^k and z_t^k as functions of mother's years of schooling, y_{t-1}^f , and social status z_{t-1}^f . These expressions, together with a detailed derivation of all the formulas in this appendix, are provided in a document titled "*Additional Derivations*", which is available on the authors' webpages (or upon request).

B.1 Correlations

We now impose the restrictions derived from this model to the formulas for the covariances that we derive in Online Appendix A and compute the correlations for different degrees of kinship. We denote the correlations by $\rho_{i, n-j, l}$, where i and j denote the corresponding relatives, and n and l are the genders of i and j respectively

Husband and wife $a - a'$

$$\rho_{a-a'} = \frac{\sigma_{zf} \sigma_{zm}}{\sigma_{yf} \sigma_{ym}} \rho_{zfzm}$$

Parent-child $aa - a'$

$$\rho_{aa,n^*-a',n'} = G_{zn'}^{n^*} \frac{\sigma_{zn^*} \sigma_{zn'}}{\sigma_{yn^*} \sigma_{yn'}}$$

Grandparent-child $aaa - a'$

$$\rho_{aaa,n^{**}-a',n'} = G_{zn'}^{n^{**}} \rho_{aa,n^*-a',n'}$$

Siblings $a' - b$

$$\rho_{a',n'-b,l} = G_{zk}^{m'} G_{zk}^l \frac{\sigma_{zk} \sigma_{zk}}{\sigma_{yn'} \sigma_{yl}} + g_k^{n'} g_k^l \frac{\sigma_{wk} \sigma_{wk}}{\sigma_{yn'} \sigma_{yl}} + \frac{\sigma_{e^{n'}e^l}}{\sigma_{yn'} \sigma_{yl}} + \frac{\sigma_{x^{n'}x^l}}{\sigma_{yn'} \sigma_{yl}}$$

Uncle/aunt (siblings of the parents) $aa - b$

$$\rho_{aa,n^*-b,l} = G_{zn'}^{m^*} \frac{\sigma_{yn'}}{\sigma_{yn^*}} \left(G_{zk}^{m'} G_{zk}^l \frac{\sigma_{zk} \sigma_{zk}}{\sigma_{yn'} \sigma_{yl}} + g_k^{n'} g_k^l \frac{\sigma_{wk} \sigma_{wk}}{\sigma_{yn'} \sigma_{yl}} + \frac{\sigma_{e^{n'}e^l}}{\sigma_{yn'} \sigma_{yl}} \right)$$

Cousins $aa - bb$

$$\rho_{aa,n^*-b,l^*} = G_{zl}^{l^*} \frac{\sigma_{yl}}{\sigma_{yl^*}} \rho_{aa,n^*-b,l}$$

Spouse of the uncle/aunt (spouses of the siblings of the parents) $aa - b'$

$$\rho_{aa,n^*-b',l'} = \frac{\sigma_{zl'}}{\sigma_{zl}} \rho_{zmzf} \frac{\sigma_{yl}}{\sigma_{yl'}} \rho_{aa,n^*-b,l}$$

Siblings in law $a - b$ or $a' - b'$

$$\rho_{a,n-b,l} = \frac{\sigma_{zn}}{\sigma_{zn'}} \rho_{zmzf} \frac{\sigma_{yn'}}{\sigma_{yn}} \left(G_{zk}^{m'} G_{zk}^l \frac{\sigma_{zk} \sigma_{zk}}{\sigma_{yn'} \sigma_{yl}} + g_k^{n'} g_k^l \frac{\sigma_{wk} \sigma_{wk}}{\sigma_{yn'} \sigma_{yl}} + \frac{\sigma_{e^{n'}e^l}}{\sigma_{yn'} \sigma_{yl}} \right)$$

$$\rho_{a',n'-b',l'} = \frac{\sigma_{zl'}}{\sigma_{zl}} \rho_{zmzf} \frac{\sigma_{yl}}{\sigma_{yl'}} \left(G_{zk}^{m'} G_{zk}^l \frac{\sigma_{zk} \sigma_{zk}}{\sigma_{yn'} \sigma_{yl}} + g_k^{n'} g_k^l \frac{\sigma_{wk} \sigma_{wk}}{\sigma_{yn'} \sigma_{yl}} + \frac{\sigma_{e^{n'}e^l}}{\sigma_{yn'} \sigma_{yl}} \right)$$

Spouse of the siblings in law $a - b'$

$$\rho_{a,n-b',l'} = \frac{\sigma_{zl'}}{\sigma_{zl}} \rho_{zmzf} \frac{\sigma_{yl}}{\sigma_{yl'}} \rho_{a,n-b,l}$$

B.2 Identification

Our baseline model cannot be solved analytically, that is we cannot write the parameters of the model as functions of the correlations between different types of relatives. However, to provide some intuition about how the parameters are identified, we show identification in this restricted model with no direct effect ($\beta = 0$)

and assortative mating occurring only in the latent factor z (i.e. we assume that the coefficients of y_{t-1}^m in the linear projections of z_{t-1}^f and y_{t-1}^f on z_{t-1}^m and y_{t-1}^m are zero).

Assortative process. First, note that the ratio of the spouse of the sibling in law to the sibling in law (or the ratio of the uncle in law to the uncle) identifies

$$\frac{\rho_{a,n-b',l'}}{\rho_{a,n-b,l}} = \frac{\rho_{aa,n^*-b',l'}}{\rho_{aa,n^*-b,l}} = \rho_{z^m z^f} \frac{\sigma_{z^{l'}} / \sigma_{y^{l'}}}{\sigma_{z^l} / \sigma_{y^l}} \quad (\text{B.1})$$

Moreover, σ_{y^m} and σ_{y^f} are observable. Notice that the ratio on the left-hand side corresponds to an instrumental variable regression in which the outcome of the spouse b in the spousal regression $b' - b$ is instrumented with the outcome of the *spouse's sibling in law* a (or the spouse's nephew or niece aa). This IV regression effectively swaps the correlations in equation (B.1) for covariances and therefore identifies $\rho_{z^m z^f} \frac{\sigma_{z^{l'}}}{\sigma_{z^l}}$. Then, if there are no gender asymmetries in the variances, that is, if $\sigma_{y^f} = \sigma_{y^m}$ and $\sigma_{z^f} = \sigma_{z^m}$, the IV regression estimates the assortative parameter $\rho_{z^m z^f}$.

The IV approach therefore needs to be based on sufficiently distant in-laws. In particular, notice that the ratio of sibling in law to sibling does not identify the assortative parameter, i.e. the spouse's *sibling* a' is not a valid instrument for the spouse b in the spousal regression $b - b'$. The reason is that the sibling component x_t is shared by siblings but not by spouses or other in-laws. For the identification of the assortative process, we therefore need to “break” the sibling link by comparing kinship moments that are sufficiently distant.

In the general model with potential gender asymmetries, we can use the product of the ratios of the correlations with the brother in law and his wife ($l = m$ and $l' = f$) and with the sister in law and his husband ($l = f$ and $l' = m$) to identify the assortative mating parameter, $\rho_{z^m z^f}$,

$$\frac{\rho_{a,n-b',f} \rho_{a,n-b',m}}{\rho_{a,n-b,m} \rho_{a,n-b,f}} = \rho_{z^m z^f}^2$$

The assortative mating parameter can also be identified from the product of the ratios of the correlations with uncle and his wife ($l = m$ and $l' = f$) and aunt and his husband ($l = f$ and $l' = m$). In contrast, standardizing the outcome variable by gender would not fully abstract from gender asymmetries. As is clear from equation (B.1), the estimates would be still biased by the gender difference in the variance share of the latent variable, $\frac{\sigma_{z^{l'}} / \sigma_{y^{l'}}}{\sigma_{z^l} / \sigma_{y^l}}$.

Intergenerational process (considering extended kins in the parent generation). Next, we can identify the reduced-form intergenerational transmission parameters, $G_{zn'}^m$, $n', n^* = m, f$, from the ratio of the spouse of the uncle to the sibling in law,

$$\frac{\rho_{aa,n^*-b',l'}}{\rho_{a',n'-b',l'}} = G_{zn'}^{m*} \frac{\sigma_{y^{n'}}}{\sigma_{y^{n^*}}}$$

Notice that this ratio corresponds to the instrumental variable regression in which the outcome of the parent a' in the parent-child regression $aa - a'$ is instrumented with the outcome of the parent's sibling in law b' (or the parent's own parent, see below).

As for the assortative process, researchers need to consider sufficiently distant relatives in order to abstract

from sibling links and to isolate the intergenerational process. In particular, notice that we cannot use the ratio of uncle to siblings to identify the intergenerational parameters because x is shared by siblings but is not transmitted to their descendants. Accordingly, the corresponding IV approach in which the outcome of the parent a' is instrumented with the parent's sibling b (i.e., the child's aunt or uncle) is biased.

Intergenerational process (considering grandparents). Alternatively, one can identify the strength of the intergenerational process from multigenerational data across three generations (as in [Lindahl et al., 2015](#), or [Braun and Stuhler, 2018](#)). In our simplified model, the ratio between the grandparent-child and the parent-child correlations identifies

$$\frac{\rho_{aaa,n^{**}-a',n'}}{\rho_{aa,n^*-a',n'}} = G_{zn'}^{n^{**}},$$

The reduced-form intergenerational transmission parameter $G_{zn'}^{n^{**}}$ depends in turn on the strength of the intergenerational transmission γ^k , the assortative parameter $\rho_{z^m z^f}$, and gender-specific weights. The corresponding IV approach of using the outcome of the grandparent a' as an instrument for the parent aa in the parent-child regression $aaa - aa$ swaps these correlations with covariances, and therefore identifies $G_{zn'}^{n^{**}} \frac{\sigma_{y^{n^{**}}}}{\sigma_{y^{n^*}}}$. Once the $G_{zn'}^{n^*}$, $n', n^* = m, f$ are identified, we can identify the share of the variances of y^f and y^m explained by the latent factor, $\frac{\sigma_{z^{n'}}^2}{\sigma_{y^{n'}}^2}$, $n' = m, f$ from the parent child correlations

$$\frac{\sigma_{z^{n'}}^2}{\sigma_{y^{n'}}^2} = \frac{\rho_{aa,n^*-a',n'}}{G_{zn'}^{n^*}}$$

Next, using the definition of $G_{zn'}^{n^*}$ for different gender combinations, we have that

$$\begin{aligned} \gamma^k \alpha_z^k &= \frac{G_{zm}^k - G_{zf}^k \frac{\sigma_{zf}}{\sigma_{zm}} \rho_{z^m z^f}}{1 - \rho_{z^m z^f}^2} \\ \gamma^k &= G_{zf}^k - \gamma^k \alpha_z^k \left(\frac{\sigma_{zm}}{\sigma_{zf}} \rho_{z^m z^f} - 1 \right) \end{aligned}$$

and we can identify γ^k and α_z^k , $k = m, f$. If there are no gender asymmetries, that is if $\gamma^f = \gamma^m = \gamma$, $\alpha^f = \alpha^m = \frac{1}{2}$, $\sigma_{yf} = \sigma_{ym}$ and $\sigma_{zf} = \sigma_{zm}$, the reduced form intergenerational transmission parameters are all equal to $\frac{\gamma}{2}(1 + \rho_{z^m z^f})$ and we can identify the pure intergenerational transmission parameter, γ , by

$$\gamma = \frac{2 \frac{\rho_{aa-b'}}{\rho_{a'-b'}}}{1 + \frac{\rho_{a-b'}}{\rho_{a-b}}} = \frac{2\rho_{aa-b'}}{\rho_{a-b} + \rho_{a-b'}}$$

Next, using the eight uncles correlations for different gender combinations ($n^*, l, k = m, f$)

$$\rho_{aa,n^*-b,l} = G_{zn'}^{n^*} \frac{\sigma_{y^{n'}}}{\sigma_{y^{n^*}}} \left(G_{zk}^{n'} G_{zl}^k \frac{\sigma_{zk}}{\sigma_{y^{n'}}} \frac{\sigma_{zk}}{\sigma_{y^l}} + g_k^{n'} g_l^k \frac{\sigma_{w^k}}{\sigma_{y^{n'}}} \frac{\sigma_{w^k}}{\sigma_{y^l}} + \frac{\sigma_{e^{n'} e^l}}{\sigma_{y^{n'} \sigma_{y^l}}} \right)$$

we can identify $\sigma_{e^{n'}}^2$, $n' = m, f$ and $\sigma_{e^m e^f}$. Finally from the three siblings correlations for different gender

combinations

$$\rho_{a',n'-b,l} = G_{zk}^{m'} G_{zk}^l \frac{\sigma_{zk}}{\sigma_{y^{n'}}} \frac{\sigma_{zk}}{\sigma_{y^l}} + g_k^{n'} g_k^l \frac{\sigma_{wk}}{\sigma_{y^{n'}}} \frac{\sigma_{wk}}{\sigma_{y^l}} + \frac{\sigma_{e^{n'}\epsilon^l}}{\sigma_{y^{n'}}\sigma_{y^l}} + \frac{\sigma_{x^{n'}x^l}}{\sigma_{y^{n'}}\sigma_{y^l}}$$

we can identify $\sigma_{x^{n'}}^2$, $n' = m, f$ and $\sigma_{x^m x^f}$.

C The Genetic Model

The genetic model is nested in our general model by imposing the following restrictions:

- There is no a direct effect of parents outcome on children outcome ($\beta^k = 0$, $k = f, m$), and hence

$$y_t^k = z_t^k + x_t^k + u_t^k$$

Then $Cov(y_t^k, z_t^k) = \sigma_z^2$ and $\rho_{z^k y^k} = \sigma_z / \sigma_{y^k}$.

- The latent factor is genetic and therefore it is transmitted from parents to children as

$$z_t^k = \frac{z_{t-1}^m + z_{t-1}^f}{2} + v_t^k$$

where v_t^k is uncorrelated across relatives and to z_{t-1}^m and z_{t-1}^f ($\gamma^k = 1$ and $\sigma_{e_k}^2 = 0$, $k = f, m$).

- The share of the variance explained by the latent factor is equal across genders ($\sigma_{z^k}^2 = \sigma_z^2$, $k = f, m$)
- There is assortative mating only in the observed outcome y ($\rho_{z^m y^f}$, $\rho_{y^m z^f}$ and $\rho_{z^m z^f}$ are functions of $\rho_{y^m y^f}$ and some of the other parameters of the model).

The genetic model has only 5 parameters: $\sigma_z^2, \sigma_{x^m}^2, \sigma_{x^f}^2, \sigma_{x^m x^f}, \rho_{y^m y^f}$.

C.1 Assortative mating process

Under the assumption of assortative mating only in y , the coefficients of the linear projections of z_{t-1}^f and y_{t-1}^f on z_{t-1}^m and y_{t-1}^m and z_{t-1}^m and y_{t-1}^m on z_{t-1}^f and y_{t-1}^f are

$$\begin{aligned} r_{zz}^m &= r_{yz}^m = r_{zz}^f = r_{yz}^f = 0 \\ r_{zy}^m &= r_{zy}^f = \frac{\sigma_z}{\sigma_{y^m}} \rho_{y^m z^f} = \frac{\sigma_z^2}{\sigma_{y^f} \sigma_{y^m}} \rho_{y^m y^f} \\ r_{yy}^m &= \frac{\sigma_{y^f}}{\sigma_{y^m}} \rho_{y^m y^f} \\ r_{zy}^f &= \frac{\sigma_z}{\sigma_{y^f}} \rho_{z^m y^f} \end{aligned}$$

We can write z_t^k and y_t^k as a function of the father

$$z_t^k = G_{zm}^k z_{t-1}^m + G_{ym}^k y_{t-1}^m + g_m^k \omega_{t-1}^m + v_t^k$$

where

$$G_{zm}^k = \frac{1}{2}, G_{ym}^k = \frac{1}{2} \frac{\sigma_z^2}{\sigma_{y^m} \sigma_{y^f}} \rho_{y^m y^f}, g_m^k = \frac{1}{2}$$

and

$$y_t^k = G_{ym}^k y_{t-1}^m + G_{zm}^k z_{t-1}^m + g_m^k \omega_{t-1}^m + v_t^k + x_t^k + u_t^k$$

These expressions will be used to compute correlations between relatives that are related through their fathers. However, when we consider relatives that are related through their mothers, we need to find expressions for y_t^k and z_t^k as functions of mother's years of schooling, y_{t-1}^f , and social status z_{t-1}^f . These expressions are provided in a document titled "*Additional Derivations*" available on the authors' webpages (or upon request).

C.2 Covariances

C.2.1 Main covariances

We use the notation in Figure 1 to denote individuals with different degrees of kinship. We first compute the main covariances (husband-wife, parent-child and siblings). Then, the covariances for other relatives are obtained recursively.

Husband and wife $a - a'$

We have to compute the covariance between "a" and "a'". Let $n' = m, f$ be the gender of a' and $n = m, f$ the gender of the a .

$$Cov(y_{t-1}^{a,n}, y_{t-1}^{a',n'}) = \sigma_{y^m} \sigma_{y^f} \rho_{y^m y^f}$$

Parent-child $aa - a'$

We have to compute the covariance between "aa" and "a'". Let $n' = m, f$ be the gender of a' and $n^* = m, f$ the gender of the aa . We project aa on a' (his/her father or mother) who has gender n' and we denote by n the gender of the spouse of a'

$$Cov(y_t^{aa,n^*}, y_{t-1}^{a',n'}) = \frac{1}{2} \left(\frac{\sigma_{y^{n'}}}{\sigma_{y^n}} \rho_{y^m y^f} + 1 \right) \sigma_{z^{n'}}$$

Siblings $a' - b$

We have to compute the covariance between "a'" and "b". Let $n' = m, f$ be the gender of a' and $l = m, f$ the gender of the b . We project a' and b on their father (or mother) $GP2$ who has gender k , and we denote

by k' the gender of the mother (or the father)

$$Cov(y_{t-1}^{a',n'}, y_{t-1}^{b,l}) = \frac{1}{2} \left(\frac{\sigma_z^2}{\sigma_{y^m} \sigma_{y^f}} \rho_{y^m y^f} + 1 \right) \sigma_z^2 + \sigma_{x^m x^f}$$

C.2.2 Other covariances

Vertical covariances

Uncle/aunt (siblings of the parents) $aa - b$

We have to compute the covariances between "aa" and "b". Let $n^* = m, f$ be the gender of aa and $l = m, f$ the gender of the b . We project aa on a' (his/her father or mother) who has gender n'

$$Cov(y_t^{aa,n^*}, y_{t-1}^{b,l}) = \frac{1}{4} \left(\frac{\sigma_z^2}{\sigma_{y^m} \sigma_{y^f}} \rho_{y^m y^f} + 1 \right)^2 \sigma_z^2 + \frac{1}{2} \frac{\sigma_z^2}{\sigma_{y^m} \sigma_{y^f}} \rho_{y^m y^f} \sigma_{x^m x^f}$$

where a' and b are siblings.

Horizontal covariances

Cousins $aa - bb$

We have to compute the covariances between "aa" and "bb". Let $n^* = m, f$ be the gender of aa and $l^* = m, f$ the gender of the ay . We project bb on b (his/her father or mother) who has gender l

$$Cov(y_t^{aa,n^*}, y_t^{bb,l^*}) = \frac{1}{8} \left(\frac{\sigma_z^2}{\sigma_{y^m} \sigma_{y^f}} \rho_{y^m y^f} + 1 \right)^3 \sigma_z^2 + \frac{1}{4} \left(\frac{\sigma_z^2}{\sigma_{y^m} \sigma_{y^f}} \rho_{y^m y^f} \right)^2 \sigma_{x^m x^f}$$

where b is the uncle/aunt of aa .

We provide the derivations for distant consanguine and affine covariances in a document titled "*Additional Derivations*", which is available on the authors' webpages (or upon request).

D The General Model with Two Unobservable Factors

We assume that the value of the output y for an individual from generation t is given by

$$y_t^k = \beta^k \tilde{y}_{t-1}^k + z_t^{G,k} + z_t^{C,k} + x_t^k + u_t^k \quad (\text{D.1})$$

where the superscript k stands for males ($k = m$) and for females ($k = f$). We assume that

$$\tilde{y}_{t-1}^k = \alpha_y^k y_{t-1}^m + (1 - \alpha_y^k) y_{t-1}^f$$

$z_t^{G,k}$ and $z_t^{C,k}$ are two unobservable factors. The genetic factor of the child, $z_t^{G,k}$, depends on the father $z_{t-1}^{G,m}$ as well as on the mother $z_{t-1}^{G,f}$

$$z_t^{G,k} = \frac{z_{t-1}^{G,m} + z_{t-1}^{G,f}}{2} + v_t^{G,k} \quad (\text{D.2})$$

The cultural factor of the child, $z_t^{C,k}$, also depends on the father $z_{t-1}^{C,m}$ as well as on the mother $z_{t-1}^{C,f}$

$$\begin{aligned} z_t^{C,k} &= \gamma^k \tilde{z}_{t-1}^k + e_t^{C,k} + v_t^{C,k} \\ \tilde{z}_{t-1}^k &= \alpha_z^k z_{t-1}^{C,m} + (1 - \alpha_z^k) z_{t-1}^{C,f} \end{aligned} \quad (\text{D.3})$$

Regarding the shocks in model (D.1), we assume that x_t^k , and $e_t^{C,k}$ are shared by all siblings of the same gender, can be correlated across siblings of different gender and are uncorrelated with the other variables (in particular with $z_t^{G,k}$, $z_t^{C,k}$ and y_{t-1}). Finally u_t^k , $v_t^{G,k}$ and $v_t^{C,k}$ are individual's white-noise error terms.

D.1 Assortative mating process

We assume there is assortative mating both in years of schooling and in the cultural factor. In particular we consider the linear projections of $z_{t-1}^{G,f}$, $z_{t-1}^{C,f}$ and y_{t-1}^f on $z_{t-1}^{G,m}$, $z_{t-1}^{C,m}$ and y_{t-1}^m :

$$\begin{aligned} z_{t-1}^{G,f} &= r_{z^G z^G}^m z_{t-1}^{G,m} + r_{z^G z^C}^m z_{t-1}^{C,m} + r_{z^G y}^m y_{t-1}^m + w_{t-1}^{G,m} \\ z_{t-1}^{C,f} &= r_{z^C z^G}^m z_{t-1}^{G,m} + r_{z^C z^C}^m z_{t-1}^{C,m} + r_{z^C y}^m y_{t-1}^m + w_{t-1}^{C,m} \\ y_{t-1}^f &= r_{y z^G}^m z_{t-1}^{G,m} + r_{y z^C}^m z_{t-1}^{C,m} + r_{y y}^m y_{t-1}^m + \varepsilon_{t-1}^m \end{aligned}$$

The coefficients of the linear projections depend on 15 correlations, $\rho_{z^G, m z^C, m}$, $\rho_{z^G, m y^m}$, $\rho_{z^C, m y^m}$, $\rho_{z^G, f z^C, f}$, $\rho_{z^G, f y^f}$, $\rho_{z^C, f y^f}$, $\rho_{z^G, m z^G, f}$, $\rho_{z^G, m z^C, f}$, $\rho_{z^C, m z^G, f}$, $\rho_{z^C, m z^C, f}$, $\rho_{z^C, m y^f}$, $\rho_{y^m z^G, f}$, $\rho_{y^m z^C, f}$ and $\rho_{y^m y^f}$, as well as on the standard deviations of $z_{t-1}^{G,k}$, $z_{t-1}^{C,k}$ and y_{t-1}^k , $k = m, f$. However, since we assume there is no assortative mating in the genetic factor, we have that $r_{z^G z^G}^m = r_{z^C z^G}^m = r_{y z^G}^m = 0$, which implies

$$\begin{aligned} \rho_{z^G, m z^G, f} &= \frac{(\rho_{z^G, m y^m} \rho_{z^C, m y^m} - \rho_{z^G, m z^C, m}) \rho_{z^C, m z^G, f} + (\rho_{z^G, m z^C, m} \rho_{z^C, m y^m} - \rho_{z^G, m y^m}) \rho_{y^m z^G, f}}{\rho_{z^C, m y^m}^2 - 1} \\ \rho_{z^G, m z^C, f} &= \frac{(\rho_{z^G, m y^m} \rho_{z^C, m y^m} - \rho_{z^G, m z^C, m}) \rho_{z^C, m z^C, f} + (\rho_{z^G, m z^C, m} \rho_{z^C, m y^m} - \rho_{z^G, m y^m}) \rho_{y^m z^C, f}}{\rho_{z^C, m y^m}^2 - 1} \\ \rho_{z^G, m y^f} &= \frac{(\rho_{z^G, m y^m} \rho_{z^C, m y^m} - \rho_{z^G, m z^C, m}) \rho_{z^C, m y^f} + (\rho_{z^G, m z^C, m} \rho_{z^C, m y^m} - \rho_{z^G, m y^m}) \rho_{y^m y^f}}{\rho_{z^C, m y^m}^2 - 1} \end{aligned} \quad (\text{D.4})$$

which reduces the number of free correlations to 12. The remaining coefficients are:

$$\begin{aligned} r_{z^G z^C}^m &= \frac{1}{(1 - \rho_{z^C, m y^m}^2)} \frac{\sigma_{z^G, f}}{\sigma_{z^C, m}} (\rho_{z^C, m z^G, f} - \rho_{z^C, m y^m} \rho_{y^m z^G, f}) \\ r_{z^G y}^m &= \frac{1}{(1 - \rho_{z^C, m y^m}^2)} \frac{\sigma_{z^G, f}}{\sigma_{y^m}} (\rho_{y^m z^G, f} - \rho_{z^C, m y^m} \rho_{z^C, m z^G, f}) \end{aligned}$$

$$\begin{aligned}
r_{z^C z^C}^m &= \frac{1}{(1 - \rho_{z^C, m y^m}^2)} \frac{\sigma_{z^C, f}}{\sigma_{z^C, m}} (\rho_{z^C, m z^C, f} - \rho_{z^C, m y^m} \rho_{y^m z^C, f}) \\
r_{z^C y}^m &= \frac{1}{(1 - \rho_{z^C, m y^m}^2)} \frac{\sigma_{z^C, f}}{\sigma_{y^m}} (\rho_{y^m z^C, f} - \rho_{z^C, m y^m} \rho_{z^C, m z^C, f}) \\
r_{y z^C}^m &= \frac{1}{(1 - \rho_{z^C, m y^m}^2)} \frac{\sigma_{y^f}}{\sigma_{z^C, m}} (\rho_{z^C, m y^f} - \rho_{z^C, m y^m} \rho_{y^m y^f}) \\
r_{yy}^m &= \frac{1}{(1 - \rho_{z^C, m y^m}^2)} \frac{\sigma_{y^f}}{\sigma_{y^m}} (\rho_{y^m y^f} - \rho_{z^C, m y^m} \rho_{z^C, m y^f})
\end{aligned}$$

We use these matching functions to write the genetic factor, $z_t^{G,k}$, the cultural factor, $z_t^{C,k}$, and years of schooling, y_t^k , as a function of father's genetic factor, $z_{t-1}^{G,m}$, cultural factor, $z_{t-1}^{C,m}$, and years of schooling, y_{t-1}^m . We write (D.2) as

$$z_t^{G,k} = G_{zgm}^k z_{t-1}^{G,m} + G_{zm}^k z_{t-1}^{C,m} + G_{ym}^k y_{t-1}^m + g_m^k w_{t-1}^{G,m} + v_t^{G,k}$$

where

$$G_{zgm}^k = \frac{1}{2}, G_{zm}^k = \frac{1}{2} r_{z^C z^C}^m, G_{ym}^k = \frac{1}{2} r_{z^C y}^m, g_m^k = \frac{1}{2},$$

(D.3) as

$$z_t^{C,k} = C_{zm}^k z_{t-1}^{C,m} + C_{ym}^k y_{t-1}^m + c_m^k \omega_{t-1}^{C,m} + e_t^{C,k} + v_t^{C,k}$$

where

$$\begin{aligned}
C_{zm}^k &= \gamma^k (\alpha_z^k + (1 - \alpha_z^k) r_{z^C z^C}^m) \\
C_{ym}^k &= \gamma^k (1 - \alpha_z^k) r_{z^C y}^m \\
c_m^k &= \gamma^k (1 - \alpha_z^k)
\end{aligned}$$

and (D.1) as

$$\begin{aligned}
y_t^k &= B_{zgm}^k z_{t-1}^{G,m} + B_{zm}^k z_{t-1}^{C,m} + B_{ym}^k y_{t-1}^m + g_m^k w_{t-1}^{G,m} + c_m^k \omega_{t-1}^{C,m} + b_m^k \varepsilon_{t-1}^m \\
&+ e_t^{G,k} + e_t^{C,k} + x_t^k + v_t^{G,k} + v_t^{C,k} + u_t^k
\end{aligned}$$

where

$$\begin{aligned}
B_{zgm}^k &= \frac{1}{2} \\
B_{zm}^k &= \beta^k (1 - \alpha_y^k) r_{y z^C}^m + \frac{1}{2} r_{z^C z^C}^m + C_{zm}^k \\
B_{ym}^k &= \beta^k (\alpha_y^k + (1 - \alpha_y^k) r_{yy}^m) + \frac{1}{2} r_{z^C y}^m + C_{ym}^k \\
b_m^k &= \beta^k (1 - \alpha_y^k)
\end{aligned}$$

These expressions will be used to compute correlations between relatives who are related through their fathers. However, when we consider relatives that are related through their mothers, we need to find expressions for y_t^k and z_t^k as functions of mother's years of schooling, y_{t-1}^f , and social status z_{t-1}^f . These expressions are provided in a document titled “*Additional Derivations*” available on the authors’ webpages (or upon request).

D.2 Steady state assumption

We assume that the second order moments of all variables are time invariant. This steady state assumption implies that $\rho_{z^C, m, z^G, m}, \rho_{z^C, m, y^m}, \rho_{z^G, m, y^m}, \rho_{z^C, f, z^G, f}, \rho_{z^C, f, y^f}$, and ρ_{z^G, f, y^f} depend on the remaining parameters of the model through the following equations:

$$\begin{aligned}
& \left(1 - \gamma^m \alpha_z^m \frac{1}{2}\right) \rho_{z^G, m, z^C, m} - \gamma^m (1 - \alpha_z^m) \frac{1}{2} \frac{\sigma_{z^C, f}}{\sigma_{z^C, m}} \frac{\sigma_{z^G, f}}{\sigma_{z^G, m}} \rho_{z^C, f, z^G, f} = \gamma^m \alpha_z^m \frac{1}{2} \frac{\sigma_{z^G, f}}{\sigma_{z^G, m}} \rho_{z^C, m, z^G, f} + \gamma^m (1 - \alpha_z^m) \frac{1}{2} \frac{\sigma_{z^C, f}}{\sigma_{z^C, m}} \rho_{z^G, m, z^C, f} \\
& \left(1 - \frac{1}{2} \gamma^f (1 - \alpha_z^f)\right) \rho_{z^G, f, z^C, f} - \frac{1}{2} \gamma^f \alpha_z^f \frac{\sigma_{z^C, m}}{\sigma_{z^C, f}} \frac{\sigma_{z^G, m}}{\sigma_{z^G, f}} \rho_{z^G, m, z^C, m} = \frac{1}{2} \gamma^f (1 - \alpha_z^f) \frac{\sigma_{z^G, m}}{\sigma_{z^G, f}} \rho_{z^G, m, z^C, f} + \frac{1}{2} \gamma^f \alpha_z^f \frac{\sigma_{z^C, m}}{\sigma_{z^C, f}} \rho_{z^C, m, z^G, f} \\
& \left(1 - \frac{1}{2} \beta^m \alpha_y^m\right) \rho_{z^G, m, y^m} - \frac{1}{2} \beta^m (1 - \alpha_y^m) \frac{\sigma_{y^f}}{\sigma_{y^m}} \frac{\sigma_{z^G, f}}{\sigma_{z^G, m}} \rho_{z^G, f, y^f} \\
& = \frac{\sigma_{z^C, m}}{\sigma_{y^m}} \rho_{z^G, m, z^C, m} + \frac{1}{2} \beta^m \alpha_y^m \frac{\sigma_{z^G, f}}{\sigma_{z^G, m}} \rho_{y^m, z^G, f} + \frac{1}{2} \beta^m (1 - \alpha_y^m) \frac{\sigma_{y^f}}{\sigma_{y^m}} \rho_{z^G, m, y^f} + \frac{\sigma_{z^G, m}}{\sigma_{y^m}} \\
& \left(1 - \frac{1}{2} \beta^f (1 - \alpha_y^f)\right) \rho_{z^G, f, y^f} - \frac{1}{2} \beta^f \alpha_y^f \frac{\sigma_{y^m}}{\sigma_{y^f}} \frac{\sigma_{z^G, m}}{\sigma_{z^G, f}} \rho_{z^G, m, y^m} \\
& = \frac{\sigma_{z^C, f}}{\sigma_{y^f}} \rho_{z^G, f, z^C, f} + \frac{1}{2} \beta^f (1 - \alpha_y^f) \frac{\sigma_{z^G, m}}{\sigma_{z^G, f}} \rho_{y^f, z^G, m} + \frac{1}{2} \beta^f \alpha_y^f \frac{\sigma_{y^m}}{\sigma_{y^f}} \rho_{z^G, f, y^m} + \frac{\sigma_{z^G, f}}{\sigma_{y^f}} \\
& (1 - \beta^m \alpha_y^m \gamma^m \alpha_z^m) \rho_{z^C, m, y^m} - \beta^m (1 - \alpha_y^m) \gamma^m (1 - \alpha_z^m) \frac{\sigma_{z^C, f}}{\sigma_{z^C, m}} \frac{\sigma_{y^f}}{\sigma_{y^m}} \rho_{z^C, f, y^f} \\
& = \frac{\sigma_{z^G, m}}{\sigma_{y^m}} \rho_{z^G, m, z^C, m} + \beta^m \alpha_y^m \gamma^m (1 - \alpha_z^m) \frac{\sigma_{z^C, f}}{\sigma_{z^C, m}} \rho_{y^m, z^C, f} + \beta^m (1 - \alpha_y^m) \gamma^m \alpha_z^m \frac{\sigma_{y^f}}{\sigma_{y^m}} \rho_{z^C, m, y^f} + \frac{\sigma_{z^C, m}}{\sigma_{y^m}} \\
& (1 - \beta^f (1 - \alpha_y^f) \gamma^f \alpha_z^f) \rho_{z^C, f, y^f} - \beta^f \alpha_y^f \gamma^f \alpha_z^f \frac{\sigma_{z^C, m}}{\sigma_{z^C, f}} \frac{\sigma_{y^m}}{\sigma_{y^f}} \rho_{z^C, m, y^m} \\
& = \frac{\sigma_{z^G, f}}{\sigma_{y^f}} \rho_{z^G, f, z^C, f} + \beta^f (1 - \alpha_y^f) \gamma^f \alpha_z^f \frac{\sigma_{z^C, m}}{\sigma_{z^C, f}} \rho_{y^f, z^C, m} + \beta^f \alpha_y^f \gamma^f (1 - \alpha_z^f) \frac{\sigma_{y^m}}{\sigma_{y^f}} \rho_{z^C, f, y^m} + \frac{\sigma_{z^C, f}}{\sigma_{y^f}}
\end{aligned}$$

The six equations for the steady state reduce the number of free correlations to four: $\rho_{z^C, m, z^C, f}, \rho_{z^C, m, y^f}, \rho_{y^m, z^C, f}$, and ρ_{y^m, y^f} . Then, this model has 21 parameters: $\beta^k, \gamma^k, \sigma_{z^G, k}, \sigma_{z^C, k}, \sigma_{x^k}^2, \sigma_{e^C, k}^2, \alpha_y^k, \alpha_z^k, k = m, f, \sigma_{x^m, x^f}, \sigma_{e^C, m, e^C, f}, \rho_{z^C, m, z^C, f}, \rho_{z^C, m, y^f}, \rho_{y^m, z^C, f}$, and ρ_{y^m, y^f} , just one parameter more than the one factor model.

D.3 Main covariances

We first compute the main covariances (husband-wife, parent-child and siblings). Then, the covariances for other relatives are obtained recursively. We again use the notation in Figure 1 to denote individuals with different degrees of kinship.

Husband and wife $a - a'$

We have to compute the covariance between " a " and " a' ". Let $n' = m, f$ be the gender of " a' " and $n = f, m$ the gender of " a ",

$$Cov(y_{t-1}^{a,n}, y_{t-1}^{a',n'}) = \sigma_{y^m} \sigma_{y^f} \rho_{y^m y^f}$$

Parent-child $aa - a'$

We have to compute the covariance between " aa " and " a' ". Let $n' = m, f$ be the gender of a' and $n^* = f, m$ the gender of aa . We project aa on a' (his/her father or mother).

$$Cov(y_t^{aa,n^*}, y_{t-1}^{a',n'}) = B_{zgn'}^* Cov(z_{t-1}^{G,a',n'}, y_{t-1}^{a',n'}) + B_{zn'}^* Cov(z_{t-1}^{C,a',n'}, y_{t-1}^{a',n'}) + B_{yn'}^* \sigma_{y^{n'}}^2$$

Siblings $a' - b$

We have to compute the covariance between " a' " and " b ". Let $n', l = m, f$ be the genders of the siblings. We can compute the covariances projecting on the father ($k = m$) or on the mother ($k = f$).

$$\begin{aligned} Cov(y_t^{a',n'}, y_t^{b,l}) &= B_{zgn'}^* B_{zgn'}^l \sigma_{z^{G,k}}^2 + B_{zkn'}^* B_{zkn'}^l \sigma_{z^{C,k}}^2 + B_{ykn'}^* B_{ykn'}^l \sigma_{y^k}^2 + \left(B_{zgn'}^* B_{zkn'}^l + B_{zkn'}^* B_{zgn'}^l \right) Cov(z_{t-1}^{G,a',k}, z_{t-1}^{C,a',k}) \\ &+ \left(B_{zgn'}^* B_{ykn'}^l + B_{ykn'}^* B_{zgn'}^l \right) Cov(z_{t-1}^{G,a',k}, y_{t-1}^{a',k}) + \left(B_{zkn'}^* B_{ykn'}^l + B_{ykn'}^* B_{zkn'}^l \right) Cov(z_{t-1}^{C,a',k}, y_{t-1}^{a',k}) + b_k^{n'} b_k^l \sigma_{\varepsilon^k}^2 \\ &+ g_k^{n'} g_k^l \sigma_{w^{G,k}}^2 + c_k^{n'} c_k^l \sigma_{w^{C,k}}^2 + \left(g_k^{n'} c_k^l + c_k^{n'} g_k^l \right) Cov(\omega_{t-1}^{G,k}, \omega_{t-1}^{C,k}) + \left(b_k^{n'} g_k^l + g_k^{n'} b_k^l \right) Cov(\omega_{t-1}^{G,k}, \varepsilon_{t-1}^m) \\ &+ \left(b_k^{n'} c_k^l + c_k^{n'} b_k^l \right) Cov(\omega_{t-1}^{C,k}, \varepsilon_{t-1}^m) + \sigma_{e^{C,n'} e^{C,l}} + \sigma_{x^{n'} x^l} \end{aligned}$$

D.4 Other covariances

Before we obtain the remaining covariances for different degrees of kinship we compute the linear projections of $z_{t-1}^{G,a',n'}$, $z_{t-1}^{C,a',n'}$ and $y_{t-1}^{a',n'}$ on $z_{t-1}^{G,b,l}$, $z_{t-1}^{C,b,l}$ and $y_{t-1}^{b,l}$, $n', l = m, f$, where a' and b are siblings.

$$\begin{aligned} z_{t-1}^{G,a',n'} &= r_{z^G z^G}^{n',l} z_{t-1}^{G,b,l} + r_{z^G z^C}^{n',l} z_{t-1}^{C,b,l} + r_{z^G y}^{n',l} y_{t-1}^{b,l} + w_{t-1}^{G,n',l} \\ z_{t-1}^{C,a',n'} &= r_{z^C z^G}^{n',l} z_{t-1}^{G,b,l} + r_{z^C z^C}^{n',l} z_{t-1}^{C,b,l} + r_{z^C y}^{n',l} y_{t-1}^{b,l} + w_{t-1}^{C,n',l} \\ y_{t-1}^{a',n'} &= r_{yz^G}^{n',l} z_{t-1}^{G,b,l} + r_{yz^C}^{n',l} z_{t-1}^{C,b,l} + r_{yy}^{n',l} y_{t-1}^{b,l} + \varepsilon_{t-1}^{n',l} \end{aligned}$$

where $w_{t-1}^{G,n',l}$, $w_{t-1}^{C,n',l}$ and $\varepsilon_{t-1}^{n',l}$ might be correlated but are uncorrelated with $z_{t-1}^{G,b,l}$, $z_{t-1}^{C,b,l}$ and $y_{t-1}^{b,l}$. We have

$$\begin{pmatrix} r_{z^G z^G}^{n',l} & r_{z^G z^C}^{n',l} & r_{z^G y}^{n',l} \\ r_{z^C z^G}^{n',l} & r_{z^C z^C}^{n',l} & r_{z^C y}^{n',l} \\ r_{yz^G}^{n',l} & r_{yz^C}^{n',l} & r_{yy}^{n',l} \end{pmatrix}' = \begin{pmatrix} \sigma_{z^G,l}^2 & \sigma_{z^G,l z^C,l} & \sigma_{z^G,l y^l} \\ \sigma_{z^G,l z^C,l} & \sigma_{z^C,l}^2 & \sigma_{z^C,l y^l} \\ \sigma_{z^G,l y^l} & \sigma_{z^C,l y^l} & \sigma_{y^l}^2 \end{pmatrix}^{-1} \begin{pmatrix} \sigma_{z^G,b,l z^G,a',n'} & \sigma_{z^G,b,l z^C,a',n'} & \sigma_{z^G,b,l y^{a',n'}} \\ \sigma_{z^C,b,l z^G,a',n'} & \sigma_{z^C,b,l z^C,a',n'} & \sigma_{z^C,b,l y^{a',n'}} \\ \sigma_{y^{b,l} z^G,a',n'} & \sigma_{y^{b,l} z^C,a',n'} & \sigma_{y^{b,l} y^{a',n'}} \end{pmatrix}$$

Consanguine relatives ("blood")

Vertical covariances

Uncle/aunt (siblings of the parents) $aa - b$

We have to compute the covariances between "aa" and "b". Let $n^* = m, f$ be the gender of aa and $l = m, f$ the gender of b . We project aa on a' (his/her father or mother) who has gender n'

$$Cov(y_t^{aa,n^*}, y_{t-1}^{b,l}) = B_{zgn'}^{n^*} Cov(z_{t-1}^{G,a',n'}, y_{t-1}^{b,l}) + B_{zn'}^{n^*} Cov(z_{t-1}^{C,a',n'}, y_{t-1}^{b,l}) + B_{yn'}^{n^*} Cov(y_{t-1}^{a',n'}, y_{t-1}^{b,l})$$

where a' and b are siblings.

Horizontal covariances

Cousins $aa - bb$

We have to compute the covariances between "aa" and "bb". Let $n^* = m, f$ be the gender of aa and $l^* = m, f$ the gender of the bb . We project bb on b (his/her father or mother) who has gender l

$$Cov(y_t^{aa,n^*}, y_t^{bb,l^*}) = B_{zgl}^{l^*} Cov(y_t^{aa,n^*}, z_{t-1}^{G,b,l}) + B_{zl}^{l^*} Cov(y_t^{aa,n^*}, z_{t-1}^{C,b,l}) + B_{yl}^{l^*} Cov(y_t^{aa,n^*}, y_{t-1}^{b,l})$$

where b is the uncle/aunt of aa .

Affinity relatives ("in-law")

Vertical covariances

Spouse of the uncle/aunt (spouses of the siblings of the parents) $aa - b'$

We have to compute the covariances between "aa" and "b'". Let $n^* = m, f$ be the gender of aa and $l' = m, f$ the gender of the b' . We project b' on his/her spouse b

$$Cov(y_t^{aa,n^*}, y_{t-1}^{b',l'}) = r_{yz^G}^l Cov(y_t^{aa,n^*}, z_{t-1}^{G,b,l}) + r_{yz^C}^l Cov(y_t^{aa,n^*}, z_{t-1}^{C,b,l}) + r_{yy}^l Cov(y_t^{aa,n^*}, y_{t-1}^{b,l})$$

where b is uncle/aunt of aa .

Siblings of the siblings in law of the parents $aa - c$

We have to compute the covariances between "aa" and "c". Let $n^* = m, f$ be the gender of aa and $o = m, f$

the gender of the c . We project c on his/her sibling b'

$$Cov(y_t^{aa,n^*}, y_{t-1}^{c,o}) = r_{yz^G}^{o,l'} Cov(y_t^{aa,n^*}, z_{t-1}^{G,b',l'}) + r_{yz^C}^{o,l'} Cov(y_t^{aa,n^*}, z_{t-1}^{C,b',l'}) + r_{yy}^{o,l'} Cov(y_t^{aa,n^*}, y_{t-1}^{b',l'})$$

where y is the spouse of the uncle/aunt of aa .

Horizontal covariances

Siblings in law $a - b$

We have to compute the covariances between " a " and " b ". Let $n = m, f$ be the gender of a and $l = m, f$ the gender of the b . We project a on his/her spouse a' with gender $n' = f, m$

$$Cov(y_{t-1}^{a,n}, y_{t-1}^{b,l}) = r_{yz^G}^{n'} Cov(z_{t-1}^{G,a',n'}, y_{t-1}^{b,l}) + r_{yz^C}^{n'} Cov(z_{t-1}^{C,a',n'}, y_{t-1}^{b,l}) + r_{yy}^{n'} Cov(y_{t-1}^{a',n'}, y_{t-1}^{b,l})$$

where a' and b are siblings.

Spouse of the siblings in law $a - b'$

We have to compute the covariances between " a " and " b' ". Let $n = m, f$ be the gender of a and $l' = m, f$ the gender of the b' . We project b' on his/her spouse b

$$Cov(y_t^{a,n}, y_{t-1}^{b',l'}) = r_{yz^G}^l Cov(y_t^{a,n}, z_{t-1}^{G,b,l}) + r_{yz^C}^l Cov(y_t^{a,n}, z_{t-1}^{C,b,l}) + r_{yy}^l Cov(y_t^{a,n}, y_{t-1}^{b,l})$$

where a and b are siblings in law.

Sibling of the sibling in law $a' - c$

We have to compute the covariances between " a' " and " c ". Let $n' = m, f$ be the gender of a' and $o = m, f$ the gender of the c . We project a' on his/her sibling b who has gender l

$$Cov(y_{t-1}^{a',n'}, y_{t-1}^{c,o}) = r_{yz^G}^{n',l} Cov(z_{t-1}^{G,b,l}, y_{t-1}^{c,o}) + r_{yz^C}^{n',l} Cov(z_{t-1}^{C,b,l}, y_{t-1}^{c,o}) + r_{yy}^{n',l} Cov(y_{t-1}^{b,l}, y_{t-1}^{c,o})$$

where b and c are siblings in law.

Cousins in law $aa - cc$

We have to compute the covariances between " aa " and " cc ". Let $n^* = m, f$ be the gender of aa and $o^* = m, f$ the gender of the cc . We project cc on c (his/her father or mother) who has gender o

$$Cov(y_t^{aa,n^*}, y_t^{cc,o^*}) = B_{zgo}^{o^*} Cov(y_t^{aa,n^*}, z_{t-1}^{G,b,o}) + B_{zo}^{o^*} Cov(y_t^{aa,n^*}, z_{t-1}^{C,b,o}) + B_{yo}^{o^*} Cov(y_t^{aa,n^*}, y_{t-1}^{b,o})$$

where c is the sibling in law of the uncle/aunt of aa .

Table E.1: Sensitivity of Main Parameters to Perturbations of Empirical Moments

	Original	Mean	St.dev	Min	P05	P25	Median	P75	P95	Max	IQR
σ_{zm}^2	2.072	1.963	0.196	1.156	1.578	1.853	1.997	2.099	2.235	2.463	0.246
σ_{zf}^2	1.559	1.455	0.187	1.019	1.141	1.309	1.475	1.596	1.740	1.973	0.288
ρ_{zmzf}	0.754	0.725	0.049	0.563	0.638	0.690	0.732	0.762	0.795	0.843	0.072
ρ_{zmyf}	0.580	0.570	0.017	0.476	0.535	0.563	0.574	0.582	0.590	0.601	0.019
ρ_{ymzf}	0.539	0.527	0.025	0.480	0.487	0.507	0.529	0.546	0.564	0.591	0.039
ρ_{ymyf}	0.489	0.489	0.007	0.476	0.478	0.483	0.489	0.495	0.500	0.502	0.012
γ^m	0.664	0.663	0.015	0.603	0.637	0.652	0.663	0.673	0.687	0.712	0.021
γ^f	0.566	0.564	0.015	0.513	0.539	0.554	0.564	0.575	0.588	0.613	0.021
β^m	0.144	0.162	0.034	0.071	0.114	0.138	0.158	0.182	0.229	0.304	0.044
β^f	0.129	0.146	0.028	0.088	0.110	0.125	0.139	0.162	0.203	0.259	0.037
σ_{xm}^2	0.180	0.177	0.037	0.029	0.115	0.149	0.177	0.205	0.235	0.283	0.056
σ_{xm}^2	0.244	0.247	0.034	0.151	0.193	0.221	0.247	0.273	0.301	0.363	0.052
σ_{xmxf}	0.068	0.064	0.031	0.000	0.016	0.041	0.064	0.087	0.114	0.153	0.046
σ_{em}^2	0.657	0.675	0.035	0.582	0.627	0.650	0.670	0.694	0.740	0.847	0.043
σ_{ef}^2	0.712	0.720	0.023	0.636	0.687	0.705	0.718	0.733	0.761	0.831	0.028
σ_{emef}	0.625	0.642	0.029	0.564	0.603	0.622	0.637	0.657	0.698	0.778	0.036
α_{zm}	0.660	0.643	0.052	0.424	0.554	0.607	0.644	0.679	0.727	0.812	0.072
α_{ym}	0.389	0.407	0.083	0.000	0.254	0.358	0.417	0.468	0.525	0.649	0.110
α_{zf}	0.775	0.748	0.054	0.517	0.648	0.716	0.755	0.787	0.826	0.906	0.072
α_{yf}	0.018	0.081	0.102	0.000	0.000	0.000	0.000	0.163	0.279	0.398	0.163

E Robustness Checks

We cannot estimate the parameters by GMM following [Abowd and Card \(1989\)](#) because the units of analysis (families) are not well defined. Moreover, most individuals will belong to different families and therefore the sample units will not be independent, as illustrated in the following example. Using the notation in the [Figure 1](#), consider family a composed by a , a' (spouse of a), aa (son of a and a'), b (sibling of a' and sibling-in-law of a), b' (spouse of b and spouse of the sibling-in-law of a), bb (nephew of a' and nephew-in-law of a), and so on up to siblings-in-law of degree 5 of a . Now consider family d composed by d (who also belongs to family a because d is the sibling-in-law of degree 3 of a), d' (the spouse of d and also part of family a), dd (son of d and d' who is not a member of family a since we are not considering nephews-in-law of degree 2), the siblings-in-law up to degree 2 of d (who are also members of family a), and the more distant in-laws of d that are not part of family a since we only consider siblings-in-law up to degree 5. As this example shows there is an overlap of some family members across families and therefore, families are not independent.

Since we cannot estimate the parameters by GMM, we cannot obtain standard errors. Instead, we perform a simulation exercise to check how robust our results are. We independently perturb each of the 105 empirical correlations used in the benchmark specification, and obtain the cali-

Table E.2: Sensitivity of Long-run and Sibling Correlations to Perturbation of Empirical Moments

	Long-run correlations				Sibling correlations		
	y (male)	y (female)	z (male)	z (female)		y	z
Parent	0.381	0.349	0.586	0.508	Brothers	0.431	0.677
Mean	0.381	0.349	0.574	0.499	Mean	0.432	0.699
Std. dev.	0.005	0.005	0.022	0.018	Std. dev.	0.006	0.039
Grandparent	0.209	0.163	0.343	0.263	Sisters	0.416	0.825
Mean	0.204	0.161	0.331	0.255	Mean	0.416	0.868
Std. dev.	0.010	0.004	0.024	0.016	Std. dev.	0.006	0.080
Ggrandparent	0.121	0.082	0.201	0.137	Brother-sister	0.376	0.711
Mean	0.116	0.080	0.191	0.131	Mean	0.376	0.742
Std. dev.	0.010	0.004	0.020	0.012	Std. dev.	0.005	0.050
GGgrandparent	0.071	0.043	0.118	0.071			
Mean	0.067	0.041	0.110	0.067			
Std. dev.	0.008	0.003	0.015	0.008			

brated parameters for this artificial economy.⁵⁰ We repeat this exercise 10,000 times and compute descriptive statistics for each parameter. The results are presented in Table E.1. The mean and the median are very close to the calibrated parameters from the original correlations and both standard deviations and interquartile ranges are small. The general picture is very similar in all the simulations. The direct transmission channels captured by β^m and β^f play a minor role. The transmission of advantages occurs instead predominantly via the latent factor, with γ^m ranging from 0.60 to 0.71 and γ^f from 0.51 to 0.62, both much larger than the corresponding β . Assortative mating occurs mainly in the latent factor.

Next, for each of the simulations we compute the implied correlation of the male (female) child and his or her ancestors on the male (female) line, both in the observable outcome and in the underlying latent factor. The results are presented in Table E.2. The average long-run correlations are similar to those implied by the original correlations and the standard deviations are very small. The kinship correlations decline more slowly with the distance between kins than a simple iteration of the parent-child correlation would suggest. In the right panel of Table E.2 we report the corresponding simulations for the sibling correlations. For all gender combinations, the average sibling correlations are very similar to the one based on the original correlations, and we always find that the correlation in the latent status is much stronger than in the observed outcome.

Finally, we study whether the objective function appears well-behaved. Consider the calibrated vector of parameters, $v^* \in \mathbb{R}^{20}$, for the benchmark case (Table 4). We construct 50 sets, $R_i \in \mathbb{R}^{20}$, $i = 1, 2, \dots, 50$, each of them farther away from the zero vector than the previous one.

⁵⁰Specifically, we multiply each correlation by a random draw from a uniform distribution in interval $[0.975, 1.025]$. We have also performed an exercise sampling the correlations from a 99% confidence interval based on asymptotic standard errors of the correlations. The results are similar and available upon request.

Figure E.1: Curvature of the Objective Function

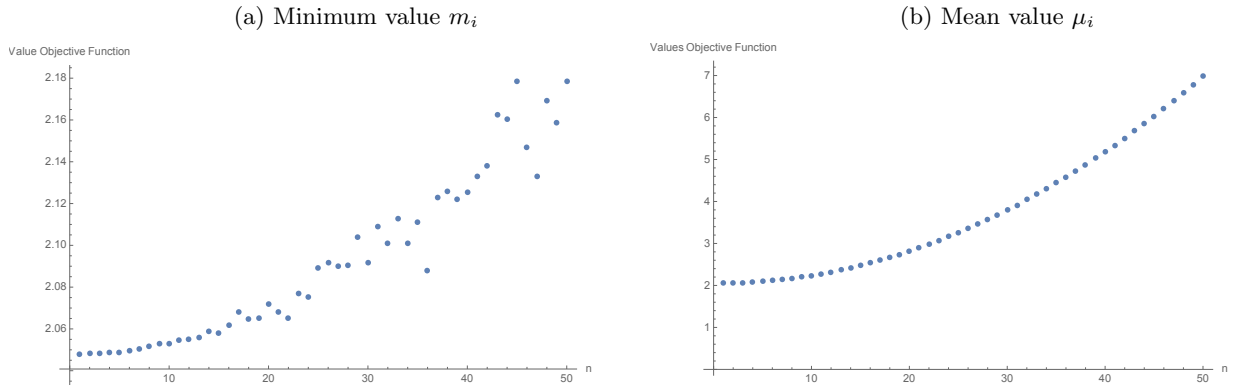

Namely, let $R_i = \{p \in \mathbb{R}^{20} : 0.001 \times i < \|p\| \leq 0.001 \times (i + 1)\}$, $i=2, 3, \dots, 50$, and $R_1 = \{p \in \mathbb{R}^{20} : \|p\| \leq 0.001\}$. Notice these sets are concentric rings and they do not overlap. For each of these 50 sets we randomly draw 200,000 points, v_{ij} , and define $v_{ij}^* = v^* + v_{ij}$. Notice that the v_{ij}^* are perturbations of v^* that are farther away from v^* the larger i is. Next, for each vector v_{ij}^* , $i = 1, \dots, 20, j = 1, \dots, 200000$ we compute the value of the objective function. Let denote by m_i the minimum value and by μ_i the mean value the objective function takes over the vectors v_{ij}^* , $j = 1, \dots, 200000$. Figure E.1 plots the results. As expected, the value of m_i increases smoothly with the distance from the global minimum v^* . The values of μ_i are also almost always increasing.

F Cohort Selection and Age Differences

F.1 Cohort distribution

Figure F.1: Distribution of Birth Cohorts (Sweden, Education)

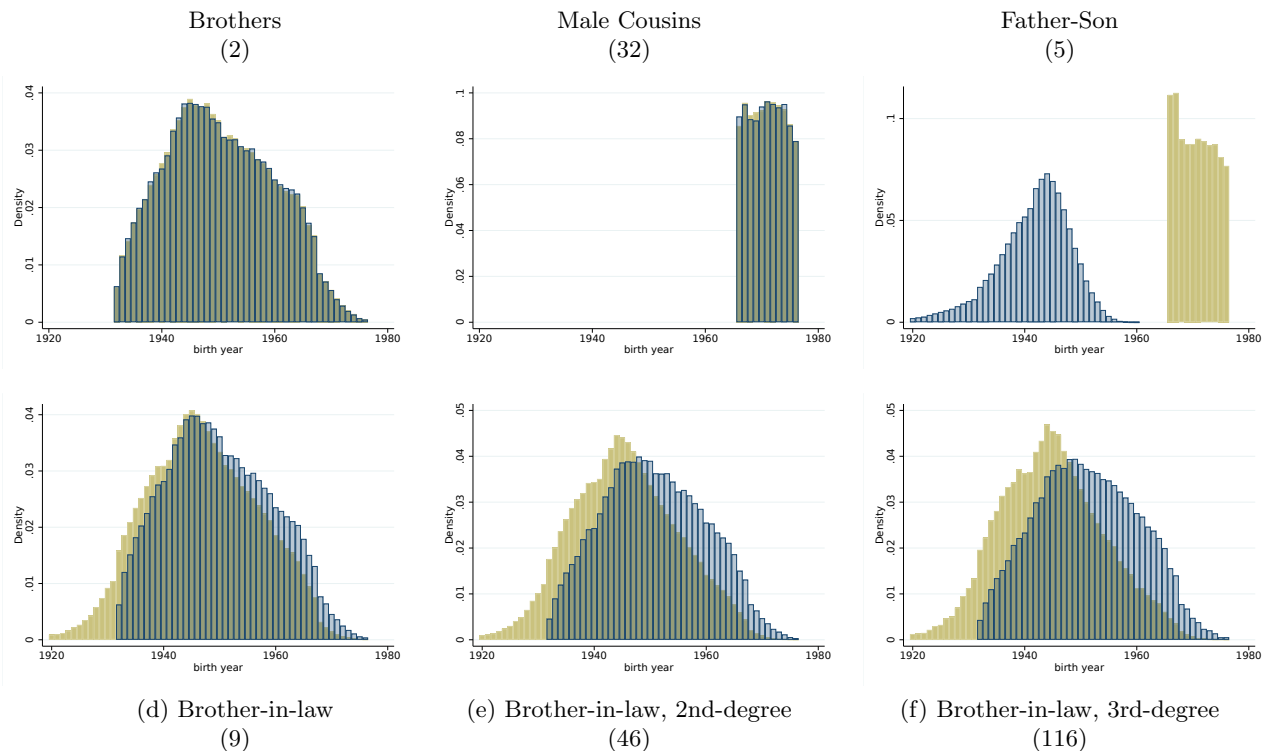

Notes: The figure plots the histogram of sampled birth cohorts for six example moments. (kinship ID in parentheses).

Multiple selection issues need to be taken into account when selecting sub-samples for each kinship moment. We first select cohorts for which the *outcome* is reliably observed, as described in Section 3.1. We then assess which *kinship types* can be reliably identified within those cohorts. For example, the identification of siblings requires observation of their parents, while for the identification of cousins we need to observe grandparents, and so on. In principle, our data contain family links up to four generations. We can match at least one biological parent for 97.5% of children born in 1966-76, the cohorts we consider for vertical moments in our main analysis. The match rate of grandparents is lower, but still above 88%.

However, we are much less likely to observe great-grandparents if a parent or grandparent had their child at a comparatively old age, which could introduce a selection bias in our estimates (see also Hällsten 2014). We therefore abstain from kinship types that depend on the identification of great-grandparents, such as second-degree cousins. We further minimize selectivity concerning the *age difference* between kins. For example, parent-child correlations tend to be lower for young parents, for whom the age difference to their children is small. We avoid this problem by considering a

range of child cohorts that is sufficiently narrow, such that their parents and their outcomes are observed irrespective of parental age-at-birth.

Close horizontal moments, such as sibling and spousal correlations, vary little with the age difference between kins. However, the issue becomes more severe for cousins and very distant in-law moments, because the age difference between kins tends to increase with the degree of separation – e.g., siblings tend to be more closely spaced than cousins. We avoid this problem by considering a broad range of cohort for all horizontal moments. The exception however are cousins. The identification of cousins requires the identification of grandparents, which can be reliably observed only for parents born after 1932 (see [Hällsten 2014](#) for a detailed discussion of the identification of cousins in the Swedish registers). We therefore consider cousins born between 1966 and 1976. Sampling earlier cohorts would introduce selectivity with respect to parental age at birth. However, restricting our analysis to cohorts 1966-76 restricts the possible age difference between cousins, which leads to a downward bias in our sample correlations for cousins (see [Appendix F.3](#)).

A final issue is that intergenerational and assortative processes may vary across birth cohorts, (see [Section 4.6](#)). We address this issue in two ways. First, we select similar cohort ranges for different kinship types, as far as possible given the other constraints mentioned above. Second, we examine if kinship correlations vary over birth cohorts. As described in [Section F.2](#), the kinship correlations in education remain quite stable in our analysis period. Most problematic are trends in the cousin correlation, because the requirement to identify grandparents forces us to consider more recent birth cohorts (such that grandparents are observed irrespective of parental age-at-birth). We return to this issue below.

[Figure F.1](#) illustrates the distribution of birth cohorts for six example moments. Sub-figures (a)-(c) show the histograms for brothers, male cousins, and father-son pairs. The sample of siblings is restricted to individuals born between 1932 (the first cohort for which parents and therefore siblings are linked) and 1976 (the last cohort before right-censoring in years of schooling becomes apparent). We further restrict the sample to those who had a child until the end of our sampling range in 2003, to increase comparability with other kinship moments that are subject to this restriction by definition. We impose the same sampling restrictions for all other “horizontal” moments. As already discussed, we are forced to draw a narrower cohort range for cousins (sub-figure b). For comparability, we sample the same cohort range for all other vertical kins, such as the father-son correlation (sub-figure c). Sub-figures (d)-(f) show the corresponding histograms for brothers-in-law of first, second and third degree of separation. The cohort distribution of the brothers-in-law (blue) is shifted to the right relative to the index person (green) because the considered brother-in-law is the *husband of the sister*, and husbands are on average older than their wives. Comparison between (d)-(f) illustrates that this age gap increases with each degree of separation (i.e., with each linkage of female spouses). To avoid selectivity issues from the interaction between such systematic and kinship-specific age shifts and the fixed sampling windows, it is essential to consider a wide

Figure F.2: Mobility Trends over Cohorts (Sweden, Education)

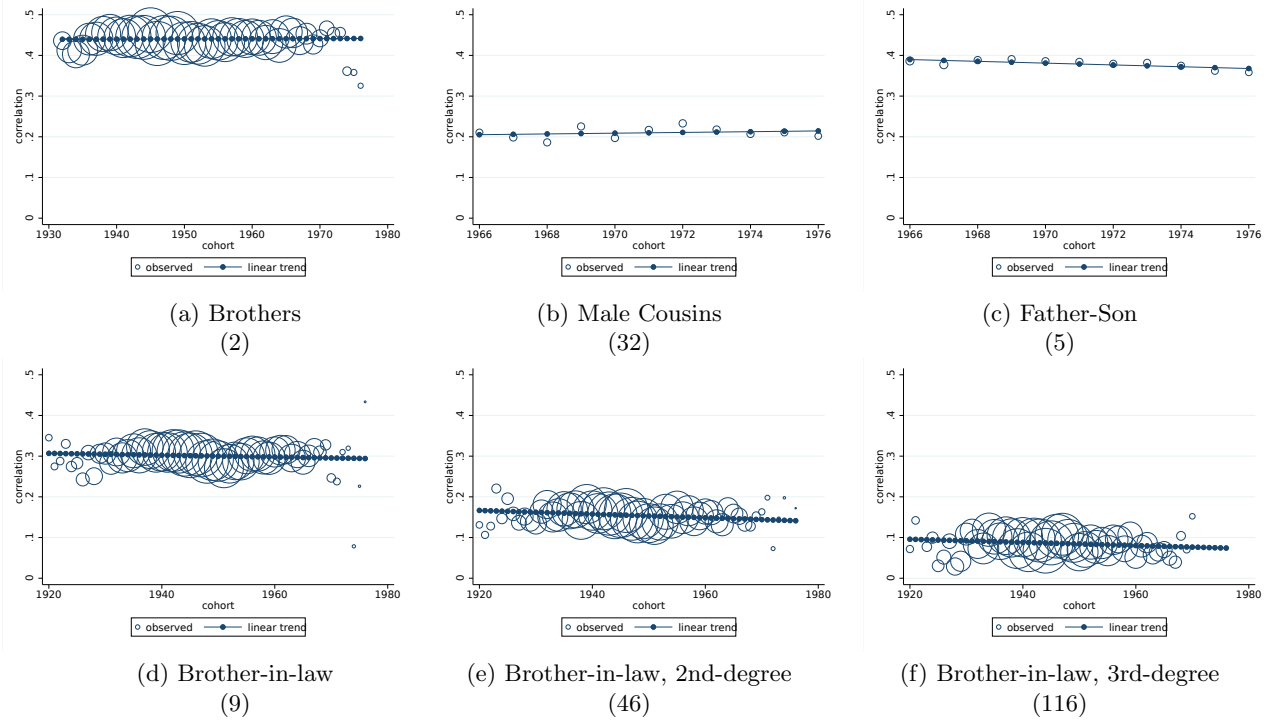

Notes: The figure plots the estimated kinship correlation separately for each birth cohort for six example moments (kinship ID in parentheses). The size of each circle is proportional to the number of observations. The birth cohorts as indicated on the x-axis are defined for one side of each kinship pair (e.g. for the son in sub-figure b) and remain unrestricted for the paired observation (e.g. the father).

cohort range for in-laws, as we do here.

F.2 Cohort trends

Kinship moments are defined over different cohorts, and may, therefore, be sensitive to shifts in the outcome distribution or other trends across cohorts. Because we can measure outcomes within the same data source and in the same periods, our approach should be less sensitive to this issue than the traditional multigenerational approach. We have nevertheless studied the non-stationarity of the outcome and kinship distributions, and standardized the outcome to minimize its consequences. Each outcome variable is demeaned by birth cohort and gender. Further standardizations of the variance (by constructing z-scores for each cohort and gender) had only negligible effects on our results. Shifts in the marginal distribution of educational outcomes are therefore not our primary concern. A more severe issue is that kinship correlations may not be stable across cohorts. To study those trends, we estimated each of our 141 kinship moments separately for each birth cohort. We find that most kinship correlations are quite stable. For illustration, Figure F.2 plots the kinship correlation in years of schooling for the same six example moments that we also considered in Section F.1. The kinship correlations for brother, male cousin and father-son pairs (subfigures a-c)

are quite stable, as are the kinship correlations for brothers-in-law of different degree of separation (sub-figures d-f). The cohort variation tends to be a bit more pronounced for moments involving females, but remain small within our sampling window. We conclude that the kinship correlations in education are sufficiently stable within the generation and range of cohorts in which they can be directly estimated. However, kinship moments may vary more substantially between generations. In particular, we estimate the cousin correlations in a narrow band of cohorts born between 1966 and 1976, and they might vary more substantially for cohorts born in the 1940s or 50s. We discuss this difficulty of fitting cousin correlations in the main text. The mobility trends are also more pronounced for the kinship correlations in income, in particular for pairings that involve female kins. As we acknowledge in the manuscript, such non-stationarity is a fundamental problem for the estimation of any distributional model. While our “horizontal” approach is arguably less affected than the “vertical” approach, accounting for non-stationarity remains a central objective for future work.

F.3 The age differences between cousins

Because the identification of cousins requires the identification of grandparents, the cohort range for cousins is narrower than for other kinship moments considered in our analysis. This restriction in the age difference leads to a downward bias in our estimated cousin correlation. To show this, we first study how their age difference is distributed in an *unrestricted* sample, for which we link cousins irrespectively of whether their education can be observed. We consider cousin pairs for which one of the cousins was born in either 1970 or 1980 (with the cohort of the second cousin unrestricted). The mean age difference is around 8 and the standard deviation around 6 for both cohorts. In contrast, the mean age difference is less than 3.5 years in our baseline sample, which contains cousins born in 1966-76 (with this restriction applying to both cousins in a cousin pair).

This restriction in our baseline sample matters because kinship correlations tend to decrease with the age difference between kins (even after standardizing outcomes by birth year). These gradients are typically quite shallow for other kinship types, but are pronounced for cousins. To show this, we plot in Figure F.3 the estimated cousin correlation separately for each possible age difference in our baseline sample (blue line). We pool male and female cousins for this exercise. While the cousin correlation is nearly 0.19 for cousins born in the same year, it falls below 0.16 for cousins spaced 10 years apart. In the data, we cannot observe cousins spaced further apart without running into selection issues related to the measurement of schooling outcomes (for cohorts born after 1976) or the observability of grandparents (for cohorts born before 1966).

Figure F.3: The Cousin Correlation and Age Differences Between Cousins

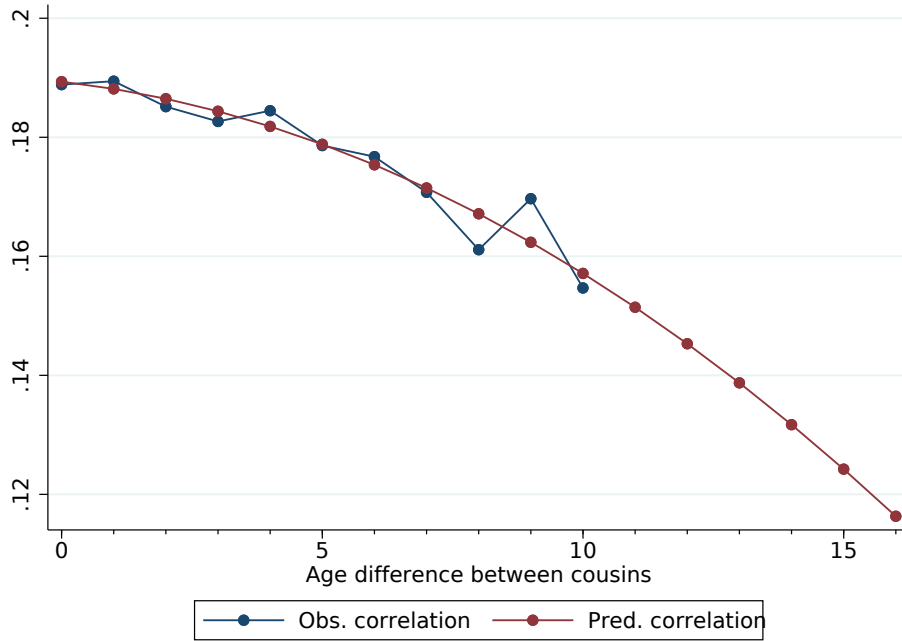

Notes: The figure plots the observed cousin correlation in years of schooling for cousin pairs with the age difference as indicated on the x-axis (blue line) and the predicted cousin correlation for larger age gaps based on a quadratic extrapolation (red line). Cohorts 1966-76, pooled sample including male and female cousins.

However, we can exploit that the cousin correlation is a relatively smooth function of the age difference, and the fact that we know the distribution of age differences in unrestricted samples (as discussed above). We first estimate a linear regression of the estimated cousin correlation by age (the blue dots in Figure F.3) on a quadratic in the age difference between cousins, to use the estimated model to predict the cousin correlation for larger age gaps (red line). We then construct a weighted average correlation by combing the age-specific predictions with weights equal to the relative density of cousins at each age point in the unrestricted sample. Finally, we compare the weighted correlations as observed in our baseline sample (the blue line) and the weighted correlation as extrapolated for an unrestricted sample (red line). While the weighted cousin correlation in our sample is 0.182 (pooled males and females cousins), the predicted correlation over the unrestricted age range is 0.160, about 14% smaller.

These results imply that the restricted age range explains about half of the gap between the raw sample correlations for cousins and the theoretical predictions from our model (see Section 4.6). For consistency we nevertheless report the raw sample correlations for cousins in our results tables.

Table G.1: Intergenerational Correlation in Individual vs. Family-average Education

Family size restriction	Individual (1)	Family (2)	Placebo family (3)
Baseline	0.387	0.439	0.387
≥ 2	0.397	0.506	0.388
≥ 3	0.398	0.557	0.382
≥ 4	0.401	0.600	0.383
≥ 5	0.404	0.635	0.405

Notes: The table reports the father-son correlation for years of schooling in column (1), for the average years of schooling among fathers/uncles and sons/nephews in column (2), and for the average among placebo pairs in column (3). Placebo pairs are based on randomly reshuffled identifiers for parental grandfathers. Row 1 is based on $N = 294,758$ father-son pairs. Subsequent rows restrict the sample to larger families with the indicated minimum number of sons/nephews, with the last row based on $N = 10,556$.

G Additional Results: Swedish Registers

G.1 Relation to name-based estimates

Our results are broadly consistent with the observation that socioeconomic status regresses more slowly to the mean on the surname than on the individual level (Clark, 2014). In this section, we provide evidence that makes this link more explicit. While our data do not contain surnames, we can average educational outcomes within a family using observed family links. For example, we can average the status of brothers in the parent generation (i.e., fathers and uncles) and their children (i.e., sons and nephews), and compare the correlation of these average measures to the correlation in individual outcomes. This is not the same as considering surnames, as we average across a small group of close relatives instead of averaging across *everyone* sharing a surname, but the approach is similar in spirit. The resulting estimates are reported in Table G.1.

For comparison, column (1) reports the individual-level correlations between years of schooling of fathers and sons. Because our analysis here requires us to restrict the sample to father-child pairs for which grandparents (and therefore uncles and nephews) are observed, the baseline estimate differs slightly from the father-child correlation reported in our paper (0.38 vs. 0.39). Column (2) reports the corresponding correlation when averaging across fathers and uncles in the parent generation and sons/nephews in the child generation (our substitute for averaging “within surnames”). The correlation increases slightly, from 0.39 vs. 0.44. Of course, most families consist of only few members. To yield estimates that are more comparable to surname-based studies we restrict our sample to larger families with an increasingly larger number of members in the child generation. While conditioning on larger families is selective, this selectivity does not affect the individual-level father-child correlation by much, as shown in column (1). However, the correlation based on surname averages increases strongly, and is as large as 0.64 once we condition on families with 5 or more sons and nephews.

The pattern in column (2) of Table G.1 is in line with the our fitted baseline model (derivation available upon request), and with the interpretation that the averaging across relatives increases the signal-to-noise ratio of education as a measure of latent advantages. Note that the increase across rows in column (2) is not a mechanical result from averaging across groups. As shown in Column (3), if we instead consider random groupings by randomly reshuffling the identifiers for grandparents, the correlation does not increase when averaging across placebo relatives. The intuition for this result is that the kinship correlations increase only if we average across individuals who are more similar to each other in their underlying “signal” (the latent variable in our model) than they are in their observable outcome (educational attainment). This is apparently true for relatives, but not for random sets of individuals.

G.2 The baseline model and income

Figure G.1: Sample and Predicted Moments (Income)

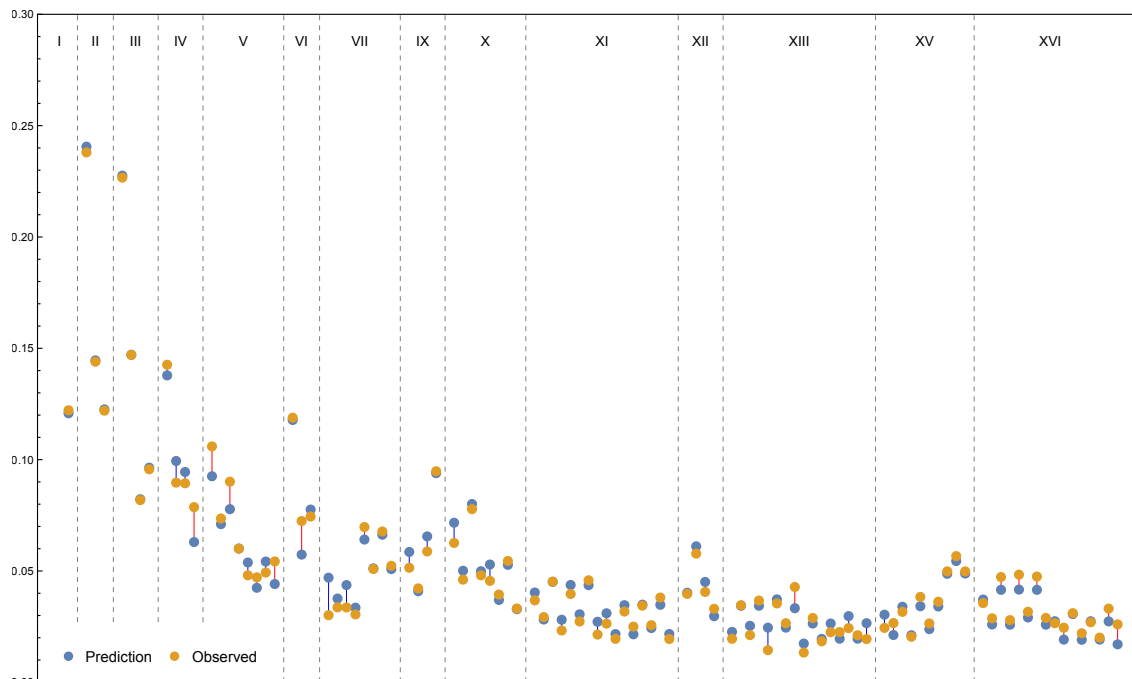

Notes: See Table G.2 for the corresponding list of kinship moments.

We consider *income* as a potentially more direct measure of socioeconomic origins and destinations.⁵¹ Because the Swedish registers track income profiles over nearly six decades, we can construct high-quality measures of income for both the parent and child generation. As detailed in Section 3.1 we measure income as the logarithm of *ten-year* averages of annual income centered

⁵¹Income has been the primary measure of socioeconomic status in the economic literature, while sociological research has focused more on education and occupation. This division is becoming less sharp, however, and occupational and educational measures are common in comparative, historical and multigenerational studies.

total pre-tax around age 35 for children and age 45 for parents.⁵² As for education, we observe 141 distinct correlations, classified into 21 kinship types. Table G.2 reports the sample size and sample correlations for a subset of those 141 moments.⁵³ The correlations are systematically lower for mixed or female than for male pairs. This pattern is consistent with the observation that women were less likely to participate in the labor force, in particular for the parent generation in our sample.⁵⁴ We base our calibration on the same 105 moments that we use also in our baseline calibration for Sweden, which includes siblings-in-law up to three degrees of separation (group XVI). We plot those moments in Figure G.1, and report all moments in Table G.2. As for education, the calibrated model explains the data well, providing a close fit to both vertical and horizontal moments, and for both direct and affinity relationships. The model also replicates the asymmetric transmission pattern across genders. As for education, we understate the correlation for cousins and very distant siblings-in-law.

Table G.3 reports the parameters of the calibrated model for income, separately by intergenerational (Panel A), sibling (Panel B), and assortative processes (Panel C). The findings vary only mildly with the chosen income definition (*ten-year*, *five-year* and *annual* incomes, *rank* or *log* incomes), and are qualitatively similar to our benchmark calibration for years of schooling. The latent advantages are more strongly transmitted than income itself, in each of the intergenerational, sibling and assortative processes. However, they are not as strongly transmitted as for the case of education. The latent determinants of income appear more persistent in the horizontal dimension. The sibling correlation in the latent factor varies around between 0.6 and 0.8, and the shared sibling components in the observable and the latent factor explain a large share of the similarity between siblings (Panel B of Table G.3). The shared sibling component in the observable is far more important than the direct transmission of income from parents to children, which explains only 2% of the variation in income for males and less for females (see Panel D of Table G.3). The spousal correlation in log income is only 0.12, consistent with endogenous labor supply decisions at the household level.⁵⁵ However, the implied spousal correlation in the latent factor is 0.8. (Panel C of Table G.3). This estimate is similar as for the case of years of schooling. We, therefore, find again that spouses are much more similar in the determinants of future economic success than they are in observable characteristics.

⁵²For robustness we also considered shorter averages (*five-year* and *annual*), and Spearman rank correlations instead of log-linear Pearson correlations. We consider *individual* income, and therefore abstract from the effect of assortative mating on *household* income (see Holmlund, 2022).

⁵³Our estimates for intergenerational and sibling correlations in income are broadly in line with prior evidence for Sweden. Estimates based on longer income spans or adjusted for measurement error are larger, see Nybom and Stuhler (2017).

⁵⁴We do not account explicitly for labor supply decisions. However, our model allows for gender differences in all its components, and for the transmission of other advantages apart from income in intergenerational and assortative processes. It is an empirical question if that model provides sufficient flexibility to fit kinship correlations for a comparatively complex outcome such as income.

⁵⁵Indeed, Holmlund (2022) shows that the spousal correlation in “potential” earnings based on the level and field of education are much larger.

Table G.2: Estimated and Calibrated Moments in Swedish Registers (Income)

Kinship		Data		Calibration		Kinship		Data		Calibration	
group	# name	# pairs	sample ρ	pred. ρ	% error	group	# name	# pairs	sample ρ	pred. ρ	% error
I	1 Spouses	412,735	0.122	0.121	-1.1		...				
II	2 Brothers	200,803	0.238	0.240	1.1		72 MF-FM-MF	154,974	0.041	0.045	11.0
<i>a'-b</i>	3 Sisters	217,722	0.144	0.144	0.4		73 FM-MF-MF	119,219	0.033	0.030	-10.1
	4 Brother-Sister	408,331	0.122	0.123	0.2	XIII	74 M \leftarrow MF-MF-MF	83,216	0.020	0.023	15.8
III	5 Father-Son	388,190	0.227	0.228	0.4	<i>aa-c'</i>	75 M \leftarrow MF-MF-FM	108,087	0.035	0.034	-0.8
<i>aa-a</i>	6 Father-Daughter	366,590	0.147	0.147	0.0		76 M \leftarrow MF-FM-MF	83,133	0.021	0.025	19.6
	7 Mother-Son	446,039	0.082	0.082	0.4		77 M \leftarrow MF-FM-FM	94,984	0.037	0.034	-6.4
	8 Mother-Daughter	422,142	0.096	0.096	0.8		78 M \leftarrow FM-MF-MF	62,612	0.014	0.025	69.8
IV	9 Brothers in-law (MF-M)	339,682	0.143	0.138	-3.3		79 M \leftarrow FM-MF-FM	78,556	0.035	0.037	5.1
<i>a-b</i>	10 Brother-Sister in-law (FM-M)	296,051	0.090	0.099	10.8		80 M \leftarrow FM-FM-MF	56,750	0.027	0.025	-7.5
	11 Brother-Sister in-law (MF-F)	362,169	0.089	0.095	5.8		81 M \leftarrow FM-FM-FM	62,983	0.043	0.033	-22.3
	12 Sisters in-law (FM-F)	301,464	0.079	0.063	-19.9		82 F \leftarrow MF-MF-MF	78,128	0.013	0.017	30.0
V	13 Nephew-Uncle (BF)	149,817	0.106	0.092	-12.7		83 F \leftarrow MF-MF-FM	102,222	0.029	0.026	-8.8
<i>aa-b</i>	14 Niece-Uncle (BF)	142,096	0.074	0.071	-3.4		84 F \leftarrow MF-FM-MF	79,019	0.018	0.019	5.8
	15 Nephew-Uncle (BM)	201,393	0.090	0.078	-13.6		85 F \leftarrow MF-FM-FM	90,190	0.022	0.026	17.3
	16 Niece-Uncle (BM)	190,299	0.060	0.060	0.1		86 F \leftarrow FM-MF-MF	59,524	0.023	0.020	-13.2
	17 Nephew-Aunt (SF)	152,065	0.048	0.054	12.0		87 F \leftarrow FM-MF-FM	75,079	0.024	0.030	22.2
	18 Niece-Aunt (SF)	142,912	0.047	0.043	-9.8		88 F \leftarrow FM-FM-MF	53,001	0.021	0.020	-7.2
	19 Nephew-Aunt (SM)	217,131	0.049	0.054	10.1		89 F \leftarrow FM-FM-FM	59,009	0.019	0.027	36.5
	20 Niece-Aunt (SM)	205,748	0.054	0.044	-18.7	XIV	90 M \leftarrow MF-MF-MF \rightarrow M	<i>41,300</i>	<i>0.017</i>	<i>0.019</i>	<i>8.5</i>
VI	21 Spouse of Sib-in-law (MF-FM)	156,164	0.119	0.118	-0.9	<i>aa-cc</i>	91 M \leftarrow MF-MF-FM \rightarrow M	<i>61,036</i>	<i>0.025</i>	<i>0.019</i>	<i>-22.5</i>
<i>a-b'</i>	22 Spouse of Sib-in-law (FM-MF)	112,873	0.072	0.057	-20.8		92 M \leftarrow MF-FM-MF \rightarrow M	<i>45,581</i>	<i>0.027</i>	<i>0.021</i>	<i>-21.9</i>
	23 Spouse of Sib-in-law (MF-MF)	251,377	0.074	0.078	4.2		93 M \leftarrow FM-MF-MF \rightarrow M	<i>31,435</i>	<i>0.033</i>	<i>0.020</i>	<i>-39.3</i>
VII	24 Nephew-Aunt in-law (BF)	120,226	0.030	0.047	56.0		94 M \leftarrow MF-MF-MF \rightarrow F	<i>38,113</i>	<i>0.022</i>	<i>0.015</i>	<i>-32.9</i>
<i>aa-b'</i>	25 Niece-Aunt in-law (BF)	114,422	0.034	0.038	11.8		95 M \leftarrow MF-MF-FM \rightarrow F	<i>58,304</i>	<i>0.022</i>	<i>0.015</i>	<i>-31.7</i>
	26 Nephew-Aunt in-law (BM)	158,116	0.034	0.044	29.8		96 M \leftarrow MF-FM-MF \rightarrow F	<i>43,614</i>	<i>0.030</i>	<i>0.017</i>	<i>-44.5</i>
	27 Niece-Aunt in-law (BM)	149,645	0.030	0.033	9.8		97 M \leftarrow MF-FM-FM \rightarrow F	<i>57,298</i>	<i>0.028</i>	<i>0.015</i>	<i>-46.5</i>
	28 Nephew-Uncle in-law (SF)	124,725	0.070	0.064	-8.0		98 M \leftarrow FM-MF-MF \rightarrow F	<i>29,951</i>	<i>0.017</i>	<i>0.016</i>	<i>-3.1</i>
	29 Niece-Uncle in-law (SF)	117,191	0.051	0.051	0.6		99 M \leftarrow FM-MF-FM \rightarrow F	<i>43,353</i>	<i>0.007</i>	<i>0.016</i>	<i>130.9</i>
	30 Nephew-Uncle in-law (SM)	179,624	0.068	0.066	-2.1		100 M \leftarrow FM-FM-MF \rightarrow F	<i>30,120</i>	<i>0.026</i>	<i>0.016</i>	<i>-38.8</i>
	31 Niece-Uncle in-law (SM)	170,499	0.052	0.051	-3.0		101 M \leftarrow FM-FM-FM \rightarrow F	<i>38,840</i>	<i>0.022</i>	<i>0.014</i>	<i>-34.1</i>
VIII	32 <i>Male Cousins (BF)</i>	<i>36,543</i>	<i>0.077</i>	<i>0.040</i>	<i>-47.4</i>		102 F \leftarrow MF-MF-MF \rightarrow F	<i>36,226</i>	<i>0.010</i>	<i>0.011</i>	<i>18.7</i>
<i>aa-bb</i>	33 <i>Male Cousins (SM)</i>	<i>62,125</i>	<i>0.072</i>	<i>0.037</i>	<i>-48.5</i>		103 F \leftarrow MF-MF-FM \rightarrow F	<i>54,841</i>	<i>0.019</i>	<i>0.011</i>	<i>-39.2</i>
	34 <i>Male Cousins (SF)</i>	<i>93,329</i>	<i>0.067</i>	<i>0.036</i>	<i>-46.0</i>		104 F \leftarrow MF-FM-MF \rightarrow F	<i>41,223</i>	<i>0.024</i>	<i>0.013</i>	<i>-46.9</i>
	35 <i>Female Cousins (BF)</i>	<i>32,984</i>	<i>0.036</i>	<i>0.025</i>	<i>-30.1</i>		105 F \leftarrow FM-MF-MF \rightarrow F	<i>28,318</i>	<i>0.014</i>	<i>0.013</i>	<i>-7.2</i>
	36 <i>Female Cousins (SM)</i>	<i>55,675</i>	<i>0.045</i>	<i>0.022</i>	<i>-50.8</i>	XV	106 F-MF-MF-M	133,431	0.024	0.030	24.3
	37 <i>Female Cousins (SF)</i>	<i>82,310</i>	<i>0.034</i>	<i>0.022</i>	<i>-34.1</i>	<i>a'-d</i>	107 F-MF-MF-F	143,881	0.027	0.021	-20.2
	38 <i>Male-Female Cousins (BF)</i>	<i>70,834</i>	<i>0.044</i>	<i>0.032</i>	<i>-27.8</i>		108 F-MF-FM-M	156,686	0.032	0.034	7.2
	39 <i>Male-Female Cousins (SM)</i>	<i>122,876</i>	<i>0.049</i>	<i>0.029</i>	<i>-41.4</i>		109 F-MF-FM-F	80,788	0.020	0.021	3.4
	40 <i>Male-Female Cousins (BM)</i>	<i>88,467</i>	<i>0.044</i>	<i>0.028</i>	<i>-36.4</i>		110 F-FM-MF-M	136,695	0.038	0.034	-10.8
	41 <i>Male-Female Cousins (SF)</i>	<i>87,582</i>	<i>0.036</i>	<i>0.029</i>	<i>-19.0</i>		111 F-FM-MF-F	73,466	0.026	0.024	-9.5
IX	42 F-MF-M	223,084	0.051	0.059	14.0		112 F-FM-FM-M	140,818	0.036	0.034	-5.8
<i>a'-c</i>	43 F-MF-F	238,392	0.042	0.041	-2.9		113 M-MF-MF-M	129,638	0.050	0.049	-2.2
	44 F-FM-M	232,232	0.059	0.066	11.6		114 M-MF-FM-M	76,528	0.057	0.054	-4.0
	45 M-MF-M	217,877	0.095	0.094	-0.9		115 M-FM-MF-M	63,988	0.050	0.049	-1.8
X	46 MF-MF-M	190,450	0.063	0.072	14.5	XVI	116 MF-MF-MF-M	115,877	0.036	0.037	4.4
<i>a-c</i>	47 MF-MF-F	204,255	0.046	0.050	8.7	<i>a-d</i>	117 MF-MF-MF-F	125,068	0.029	0.026	-9.6
	48 MF-FM-M	207,353	0.078	0.080	2.9		118 MF-MF-FM-M	139,577	0.047	0.041	-12.3
	49 MF-FM-F	213,663	0.048	0.050	3.8		119 MF-MF-FM-F	143,320	0.028	0.026	-7.4
	50 FM-MF-M	163,588	0.046	0.053	16.2		120 MF-FM-MF-M	123,894	0.048	0.042	-13.8
	51 FM-MF-F	173,923	0.039	0.037	-6.0		121 MF-FM-MF-F	133,139	0.032	0.029	-8.1
	52 FM-FM-M	157,713	0.055	0.053	-3.3		122 MF-FM-FM-M	131,608	0.047	0.041	-12.6
	53 FM-FM-F	160,923	0.033	0.033	-0.9		123 MF-FM-FM-F	134,253	0.029	0.026	-10.5
XI	54 M \leftarrow MF-MF-M	113,118	0.037	0.040	9.6		124 FM-MF-MF-M	97,448	0.027	0.027	3.4
<i>aa-c</i>	55 M \leftarrow MF-MF-F	121,696	0.029	0.028	-3.7		125 FM-MF-MF-F	105,868	0.025	0.019	-21.8
	56 M \leftarrow MF-FM-M	108,145	0.045	0.045	-0.4		126 FM-MF-FM-M	113,190	0.031	0.031	-1.3
	57 M \leftarrow MF-FM-F	111,238	0.023	0.028	20.7		127 FM-MF-FM-F	115,798	0.022	0.019	-13.3
	58 M \leftarrow FM-MF-M	84,217	0.040	0.044	10.3		128 FM-FM-MF-M	92,992	0.027	0.027	1.7
	59 M \leftarrow FM-MF-F	89,595	0.027	0.031	11.9		129 FM-FM-MF-F	99,601	0.020	0.019	-4.4
	60 M \leftarrow FM-FM-M	73,134	0.046	0.044	-4.8		130 FM-FM-FM-M	92,574	0.033	0.027	-17.5
	61 M \leftarrow FM-FM-F	74,708	0.021	0.027	26.9		131 FM-FM-FM-F	95,272	0.026	0.017	-34.6
	62 F \leftarrow MF-MF-M	106,389	0.026	0.031	17.4	XVII	132 MF-MF-MF-MF	<i>82,420</i>	<i>0.022</i>	<i>0.021</i>	<i>-4.6</i>
	63 F \leftarrow MF-MF-F	114,915	0.020	0.022	11.0	<i>a-d'</i>	133 MF-MF-MF-FM	<i>116,816</i>	<i>0.034</i>	<i>0.032</i>	<i>-7.6</i>
	64 F \leftarrow MF-FM-M	102,747	0.032	0.035	8.8	XVIII	134 MF-MF-MF-MF-M	<i>75,822</i>	<i>0.026</i>	<i>0.019</i>	<i>-26.4</i>
	65 F \leftarrow MF-FM-F	105,813	0.025	0.022	-13.7	<i>a-e</i>	135 FM-FM-FM-FM-F	<i>61,230</i>	<i>0.018</i>	<i>0.009</i>	<i>-51.1</i>
	66 F \leftarrow FM-MF-M	79,920	0.034	0.035	1.4	XIX	136 MF-MF-MF-MF-MF	<i>53,670</i>	<i>0.025</i>	<i>0.011</i>	<i>-57.0</i>
	67 F \leftarrow FM-MF-F	85,898	0.026	0.024	-4.8	<i>a-e'</i>	137 MF-MF-MF-MF-FM	<i>79,620</i>	<i>0.026</i>	<i>0.016</i>	<i>-38.1</i>
	68 F \leftarrow FM-FM-M	68,471	0.038	0.035	-8.6	XX	138 MF-MF-MF-MF-MF-M	<i>53,098</i>	<i>0.015</i>	<i>0.010</i>	<i>-32.1</i>
	69 F \leftarrow FM-FM-F	69,793	0.019	0.022	11.6	<i>a-f</i>	139 FM-FM-FM-FM-FM-F	<i>42,278</i>	<i>0.003</i>	<i>0.005</i>	<i>39.3</i>
XII	70 MF-MF-MF	137,086	0.040	0.040	1.2	XXI	140 MF-MF-MF-MF-MF-MF	<i>37,586</i>	<i>0.009</i>	<i>0.006</i>	<i>-40.3</i>
<i>a-c'</i>	71 MF-MF-FM	185,967	0.058	0.061	5.6	<i>a-f'</i>	141 MF-MF-MF-MF-MF-FM	<i>57,789</i>	<i>0.023</i>	<i>0.009</i>	<i>-62.4</i>

Notes: M/F indicate gender, MF or FM are spouses, - indicates a sibling link and \rightarrow indicates a parent-child link. Other abbreviations are BF=Brother of the father, BM=Brother of the mother, SF=Sister of the father and SM=Sister of the mother. Moments printed in italics were not used in the calibration.

Table G.3: Calibrated Parameters in Swedish Registers (Income)

<i>Panel A: Intergenerational Processes</i>							
β^m	β^f	γ^m	γ^f	σ_{ym}^2	σ_{yf}^2	σ_{zm}^2	σ_{zf}^2
0.144	0.103	0.615	0.423	0.304	0.248	0.058	0.027
a_{ym}	a_{yf}	a_{zm}	a_{zf}	σ_{um}^2	σ_{uf}^2		
1.000	0.640	0.068	0.239	0.217	0.202		
<i>Ancestor correlations in y and z:</i>							
	Father-Son	Fr.-Daughter	Mother-Son	Mother-Daughter			
<i>in z</i>	0.354	0.407	0.423	0.441			
	Father-Son	Grandfr.-Son	GGrandfr.-Son	GGrandfr.-Son			
<i>in y</i>	0.228	0.065	0.021	0.007			
<i>in z</i>	0.354	0.129	0.046	0.016			
<i>Panel B: Sibling Processes</i>							
	σ_{xm}^2	σ_{xf}^2	σ_{xmf}	σ_{em}^2	σ_{ef}^2	σ_{emef}	
	0.014	0.014	0.000	0.035	0.011	0.018	
<i>Sibling correlations in y and z:</i>							
	Brothers	Sisters	Mixed		Brothers	Sisters	Mixed
<i>in y</i>	0.240	0.144	0.123	<i>in z</i>	0.774	0.603	0.645
<i>Panel C: Assortative Processes</i>							
r_{zz}^m	r_{zy}^m	r_{yz}^m	r_{yy}^m	r_{zz}^f	r_{zy}^f	r_{yz}^f	r_{yy}^f
0.517	0.026	0.569	-0.007	1.187	-0.005	1.532	-0.043
<i>Spousal correlations in y and z:</i>							
ρ_{ymyf}	ρ_{zmzf}	ρ_{ymzf}	ρ_{zmym}				
0.121	0.803	0.442	0.272				
<i>Panel D: Variance Decomposition of y</i>							
	\tilde{y}_{t-1}	\tilde{z}_{t-1}	$\sigma_{\tilde{y}\tilde{z}}$	$\Sigma_{\tilde{y},\tilde{z}}$	x_t	e_t	$\Sigma_{\tilde{y},\tilde{z},x,e}$
<i>male</i>	2.1%	3.4%	2.4%	7.9%	4.7%	11.4%	24.0%
<i>female</i>	0.7%	2.2%	1.4%	4.3%	5.7%	4.3%	14.4%

Notes: Panels A and B report parameter estimates and implied ancestor and sibling correlations in log income y and latent advantages z . The parameters β and σ_y^2 capture the direct transmission and variance of y ; γ and σ_z^2 the transmission and variance of z ; and σ_x^2 and σ_e^2 shared sibling influences in y and z ; see equations (1)-(3) for details. Panel C reports the coefficients from the linear projections (4) and (5) of z^k and y^k for $k = f, m$ on their spouse's z and y and the implied spousal correlations. Panel D decomposes σ_y^2 into the components explained by the parents' y (\tilde{y}_{t-1}) and z (\tilde{z}_{t-1}) and their covariance ($\sigma_{\tilde{y}\tilde{z}}$), and the sibling components in y (x_t) and z (e_t); $\Sigma_{\tilde{y},\tilde{z}}$ and $\Sigma_{\tilde{y},\tilde{z},x,e}$ are the total percentages explained by the parents and the close family (parental and shared sibling influences), respectively. Based on the kinship correlations reported in Table G.2.

In sum, these estimates confirm that our qualitative findings extend to socioeconomic outcomes other than educational attainment. However, the strength of the vertical transmission processes vary. One interpretation is that different factors influence different aspects of socioeconomic status, and that some factors have higher persistence than others. The recent multigenerational literature is not very informative about this question, because income is not or not well observed in historical sources. Our “horizontal” approach does not face such constraints and can, therefore, be used to study transmission across a broader set of outcomes. Our evidence suggests that those factors that determine educational attainment are more strongly transmitted from one generation to the next than those factors that influence earnings.

G.3 The baseline model and height

Table G.4: Estimated and Calibrated Moments in Swedish Registers (Height)

Kinship		Data		Calibration		Kinship		Data		Calibration	
group	# name	# pairs	ρ	general	genetic	group	# name	# pairs	ρ	general	genetic
I	1 Spouses	External	0.270	0.270	0.291		...				
II	2 Brothers	112,549	0.522	0.522	0.526		56 M←MF-FM-M	37,029	0.053	0.053	0.044
	3 Sisters	External	0.535	0.536	0.541		58 M←FM-MF-M	43,068	0.047	0.054	0.040
	4 Brother-Sister			0.456	0.484		60 M←FM-FM-M	29,437	0.059	0.058	0.043
III	5 Father-Son	46,441	0.483	0.487	0.483	XII	71 MF-MF-FM	39,288	0.023	0.032	0.006
	6 Father-Daughter			0.217	0.483	XIII	75 M←MF-MF-FM	29,311	0.017	0.028	0.013
	7 Mother-Son			0.608	0.483		77 M←MF-FM-FM	21,488	0.022	0.028	0.012
IV	8 Mother-Daughter			0.729	0.483		79 M←FM-MF-FM	26,207	0.037	0.038	0.013
	9 Brothers-in-law (MF-M)	135,006	0.111	0.115	0.141		81 M←FM-FM-FM	16,828	0.033	0.035	0.012
	10 Brother-Sister in-law (FM-M)			0.196	0.153	XIV	90 M←MF-MF-MF→M	24,274	0.025	0.034	0.023
V	11 Brother-Sister in-law (MF-F)			0.159	0.158		91 M←MF-MF-FM→M	27,032	0.043	0.031	0.023
	12 Sisters in-law (FM-F)			0.292	0.141		92 M←MF-FM-MF→M	27,089	0.040	0.038	0.024
	13 Nephew-Uncle (BF)	52,618	0.260	0.268	0.285		93 M←FM-MF-MF→M	25,681	0.036	0.044	0.023
VI	15 Nephew-Uncle (BM)	66,270	0.289	0.293	0.280	XV	113 M-MF-MF-M	50,330	0.041	0.035	0.010
	21 Spouse of Sib. in-law (MF)	44,034	0.067	0.053	0.046		114 M-MF-FM-M	25,234	0.042	0.042	0.013
	28 Nephew-Uncle in-law (SF)	28,901	0.077	0.075	0.082	XVI	115 M-FM-MF-M	29,208	0.031	0.030	0.010
VII	30 Nephew-Uncle in-law (SM)	39,634	0.073	0.077	0.084		116 MF-MF-MF-M	30,183	0.025	0.026	0.003
	32 Male Cousins (BF)	21,153	0.160	0.148	0.170		118 MF-MF-FM-M	30,538	0.026	0.031	0.003
	33 Male Cousins (SM)	21,937	0.188	0.188	0.170		120 MF-FM-MF-M	36,879	0.032	0.026	0.003
VIII	34 Male Cousins (SF)	45,689	0.167	0.152	0.169		122 MF-FM-FM-M	33,478	0.025	0.031	0.003
	45 M-MF-M	99,219	0.074	0.078	0.074	XVII	133 MF-MF-MF-FM	19,846	0.016	0.024	0.001
	46 MF-MF-M	59,544	0.039	0.039	0.020	XVIII	134 MF-MF-MF-MF-M	16,980	0.020	0.020	0.000
IX	48 MF-FM-M	63,798	0.053	0.046	0.024	XIX	137 MF-MF-MF-MF-FM	11,286	0.009	0.019	0.000
	54 M←MF-MF-M	46,771	0.048	0.046	0.040	XX	138 MF-MF-MF-MF-MF-M	10,309	0.015	0.016	0.000
XI					XXI	141 MF-MF-MF-MF-MF-FM	6,873	0.044	0.015	0.000	

Notes: Kinship correlations from Swedish registers. See Table 3 for notation.

In this section we calibrate our baseline model for *body height*, which we observe from military enlistment tests that were universal for the male Swedish population (see Section 3.1). Height is an interesting reference point because it is known to be primarily determined by genes, at least in populations that are not exposed to famine or undernutrition.⁵⁶ It is subject to only comparatively weak assortative processes, which was one of the reasons why Francis Galton considered height in his famous work on linear regression (Galton, 1886). Because the transmission of body height is better understood, the plausibility of our findings is easier to evaluate for height than for socioeconomic outcomes. Moreover, we observe height only for males, and it is an interesting question to what extent female outcomes need to be observed to identify our model, including the assortative and gender-specific processes.

Table G.4 reports the sample correlations. We observe 39 (male) kinship correlations.⁵⁷ To these we add the correlation in height between spouses and between sisters from external sources.⁵⁸ The predicted moments from the calibrated model are reported in Table G.4, while Figure G.2a plots the 105 kinship moments that are included in our baseline calibration for educational attainment. As for education and income, the calibrated model explains our data well, providing a close fit to

⁵⁶The proportion of the total variation in body height in a population that is due to genetic variation is estimated to be around 0.8 (Silventoinen, 2003). Accordingly, the correlation in body height is much higher in biological than foster families, and can be as high as 0.99 for monozygotic twins.

⁵⁷Because the military enlistments tests cover only birth cohorts born between 1950 and 1980, we observe fewer observations than for the other outcomes. The moments are however precisely estimated, and in line with prior evidence. For example, the father-son correlation in height in our sample is 0.48, the same value as reported by Grönqvist et al. (2017).

⁵⁸Price and Vandenberg (1980) report a spousal correlation in height of 0.27 for Swedish couples. To calibrate the correlation in height for sisters, we assume that the gap to the corresponding correlation for brothers is as large as in Norwegian sources reported in Tambs et al. (1992).

Table G.5: Calibrated Parameters in Swedish Registers (Height, Baseline Model)

<i>Panel A: Intergenerational Processes</i>							
β^m	β^f	γ^m	γ^f	σ_{ym}^2	σ_{yf}^2	σ_{zm}^2	σ_{zf}^2
0.948	0.757	1.017	0.118	1.000	1.000	0.102	0.001
a_{ym}	a_{yf}	a_{zm}	a_{zf}	σ_{um}^2	σ_{uf}^2		
0.311	0.019	0.688	0.874	0.435	0.464		
<i>Ancestor correlations in y and z:</i>							
	Father-Son	Fr.-Daughter	Mother-Son	Mother-Daughter			
<i>in z</i>	0.731	0.958	0.672	0.876			
	Father-Son	Grandfr.-Son	GGrandfr.-Son	GGGrandfr.-Son			
<i>in y</i>	0.487	0.236	0.113	0.053			
<i>in z</i>	0.731	0.532	0.389	0.284			
<i>Panel B: Sibling Processes</i>							
	σ_{xm}^2	σ_{xf}^2	σ_{xmf}	σ_{em}^2	σ_{ef}^2	σ_{emef}	
	0.000	0.003	0.000	0.004	0.000	0.001	
<i>Sibling correlations in y and z:</i>							
	Brothers	Sisters	Mixed		Brothers	Sisters	Mixed
<i>in y</i>	0.522	0.536	0.456	<i>in z</i>	0.579	1.000	0.784
<i>Panel C: Assortative Processes</i>							
r_{zz}^m	r_{zy}^m	r_{yz}^m	r_{yy}^m	r_{zz}^f	r_{zy}^f	r_{yz}^f	r_{yy}^f
0.101	-0.008	-1.775	0.315	7.558	-0.081	-2.501	0.240
<i>Spousal correlations in y and z:</i>							
ρ_{ymyf}	ρ_{zmzf}	ρ_{ymzf}	ρ_{zmyf}				
0.270	0.912	-0.170	-0.541				
<i>Panel D: Variance Decomposition of y</i>							
	\tilde{y}_{t-1}	\tilde{z}_{t-1}	$\sigma_{\tilde{y}\tilde{z}}$	$\Sigma_{\tilde{y},\tilde{z}}$	x_t	e_t	$\Sigma_{\tilde{y},\tilde{z},x,e}$
<i>male</i>	61.7%	5.4%	-15.3%	51.8%	0.0%	0.4%	52.2%
<i>female</i>	55.8%	0.1%	-2.7%	53.3%	0.3%	0.0%	53.6%

Notes: Panels A and B report parameter estimates and implied ancestor and sibling correlations in height y and latent advantages z . The parameters β and σ_y^2 capture the direct transmission and variance of y ; γ and σ_z^2 the transmission and variance of z ; and σ_x^2 and σ_e^2 shared sibling influences in y and z ; see equations (1)-(3) for details. Panel C reports the coefficients from the linear projections (4) and (5) of z^k and y^k for $k = f, m$ on their spouse's z and y and the implied spousal correlations. Panel D decomposes σ_y^2 into the components explained by the parents' y (\tilde{y}_{t-1}) and z (\tilde{z}_{t-1}) and their covariance ($\sigma_{\tilde{y}\tilde{z}}$), and the sibling components in y (x_t) and z (e_t); $\Sigma_{\tilde{y}\tilde{z}}$ and $\Sigma_{\tilde{y},\tilde{z},x,e}$ are the total percentages explained by the parents and the close family (parental and shared sibling influences), respectively. Based on the kinship correlations reported in Table G.4.

both vertical and horizontal moments, and for both direct and affinity relationships. However, in the absence of direct observations, we appear unable to fit the correlations for female kins – the calibrated model predicts much larger correlations for distant kinships that involve female than those that involve male.

Table G.5 reports the estimated parameters. The transmission process for height can be well approximated by direct transmission channels – observed height explains well the height of descendants and other family members. Despite its strong intergenerational transmission ($\beta^m = 0.95$ and $\beta^f = 0.76$), the father-child and mother-child correlations in height remain modest because the spousal correlation in height ($\rho_{y_m y_f} = 0.27$) is much smaller than the corresponding spousal correlations in socioeconomic outcomes. The implied spousal correlations in the latent factor is large,

but less relevant because the latent factor explains hardly any of the variation in the outcome.

G.4 The standard genetic model and height

Figure G.2: Sample and Predicted Moments (Height)

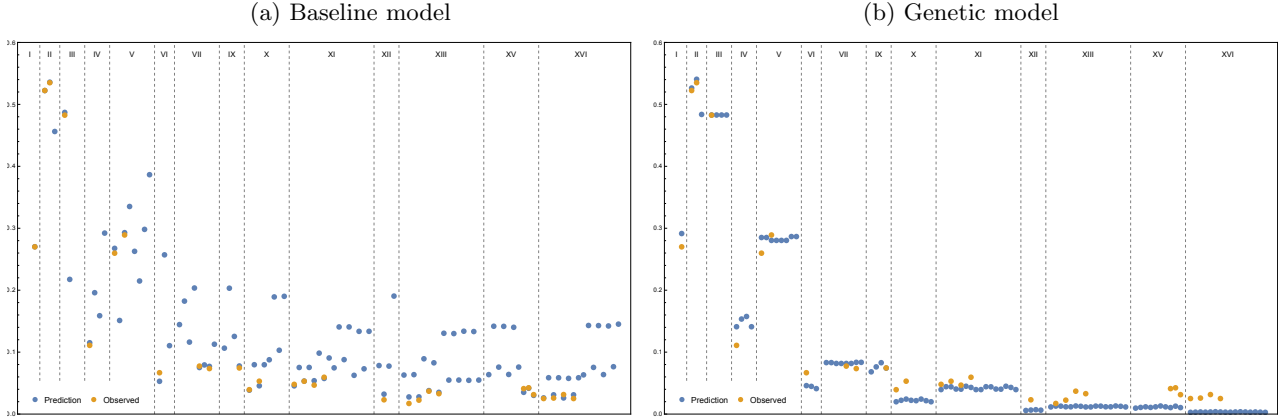

Notes: See Table G.4 for the corresponding list of kinship moments.

Genes are known to be the primary source of variation in height (Silventoinen, 2003). We therefore study if the standard genetic model described in Section 5.1 can provide a comparatively good fit, despite having much fewer parameters than our baseline model. We use the same 41 kinship correlations as for calibration of the baseline model, as described in Section G.3. The sample and predicted moments are reported in Table G.4. As illustrated in Figure G.2b, the genetic model provides a worse fit to in-sample moments. However, it fits close relatives such as spouses and siblings quite well and generates out-of-sample predictions that are more stable within kinship types than the widely varying predictions of the general model.

Table G.6 summarizes the results.⁵⁹ The latent factor of the parents \tilde{z}_{t-1} explains about 45.5% of the variation in height (see Panel D), and a child’s own latent factor z_t explains 75%. This latter estimate is slightly below estimates of the heritability of height from quantitative genetics, which tend to be around 80% (Silventoinen, 2003). In principle, our approach can capture latent determinants other than genes, and can therefore be interpreted as an upper bound for heritability.⁶⁰ That our estimates are close to those from the genetic literature suggests therefore that the parent-child correlation in height is nearly exclusively due to genes, and not other factors. Finally, the spousal correlation in phenotype height is greater than the spousal correlation in genotype height (Panel C), consistent with the assumption that assortative mating occurs exclusively on the phenotype. In contrast, our baseline model allows for spouses to be more similar than indicated

⁵⁹In contrast to the standard model described above, we allow $\sigma_{e_k}^2$ to be non-zero in the calibration (e.g. to account for the presence of monozygotic twins in our data). This added flexibility has only a negligible effect on the results.

⁶⁰See Ruby et al. (2018) for a similar upper-bound argument for the case of human *longevity*.

Table G.6: Calibrated Parameters in Swedish Registers (Height, Genetic Model)

<i>Panel A: Intergenerational Processes</i>							
β^m	β^f	γ^m	γ^f	σ_{ym}^2	σ_{yf}^2	σ_{zm}^2	σ_{zf}^2
0.000	0.000	1.000	1.000	1.000	1.000	0.748	0.748
a_{ym}	a_{yf}	a_{zm}	a_{zf}	σ_{um}^2	σ_{uf}^2		
0.000	0.000	0.500	0.500	0.181	0.167		
<i>Ancestor correlations in y and z:</i>							
	Father-Son	Fr.-Daughter	Mother-Son	Mother-Daughter			
<i>in z</i>	0.609	0.609	0.609	0.609			
	Father-Son	Grandfr.-Son	GGrandfr.-Son	GGrandfr.-Son			
<i>in y</i>	0.483	0.294	0.179	0.109			
<i>in z</i>	0.609	0.379	0.231	0.141			
<i>Panel B: Sibling Processes</i>							
	σ_{xm}^2	σ_{xf}^2	σ_{xmf}	σ_{em}^2	σ_{ef}^2	σ_{emef}	
	0.071	0.085	0.028	0.000	0.000	0.000	
<i>Sibling correlations in y and z:</i>							
	Brothers	Sisters	Mixed		Brothers	Sisters	Mixed
<i>in y</i>	0.526	0.541	0.484	<i>in z</i>	0.609	0.609	0.609
<i>Panel C: Assortative Processes</i>							
r_{zz}^m	r_{zy}^m	r_{yz}^m	r_{yy}^m	r_{zz}^f	r_{zy}^f	r_{yz}^f	r_{yy}^f
0.000	0.218	0.000	0.291	0.000	0.218	0.000	0.291
<i>Spousal correlations in y and z:</i>							
ρ_{ymyf}	ρ_{zmzf}	ρ_{ymzf}	ρ_{zmyf}				
0.291	0.218	0.252	0.252				
<i>Panel D: Variance Decomposition of y</i>							
	\tilde{y}_{t-1}	\tilde{z}_{t-1}	$\sigma_{\tilde{y}\tilde{z}}$	$\Sigma_{\tilde{y},\tilde{z}}$	x_t	e_t	$\Sigma_{\tilde{y},\tilde{z},x,e}$
<i>male</i>	0.0%	45.5%	0.0%	45.5%	7.1%	0.0%	52.6%
<i>female</i>	0.0%	45.5%	0.0%	45.5%	8.5%	0.0%	54.1%

Notes: Panels A and B report parameter estimates and implied ancestor and sibling correlations in height y and latent genetic advantages z . The parameters β and σ_y^2 capture the direct transmission and variance of y ; γ and σ_z^2 the transmission and variance of z ; and σ_x^2 and σ_e^2 shared sibling influences in y and z ; see equations (1)-(3) and (7) for details. Panel C reports the coefficients from the linear projections (4) and (5) of z^k and y^k for $k = f, m$ on their spouse's z and y and the implied spousal correlations. Panel D decomposes σ_y^2 into the components explained by the parents' y (\tilde{y}_{t-1}) and z (\tilde{z}_{t-1}) and their covariance ($\sigma_{\tilde{y}\tilde{z}}$), and the sibling components in y (x_t) and z (e_t); $\Sigma_{\tilde{y},\tilde{z}}$ and $\Sigma_{\tilde{y},\tilde{z},x,e}$ are the total percentages explained by the parents and the close family (parental and shared sibling influences), respectively. Based on the kinship correlations reported in Table G.4.

by their observed outcomes. As a consequence, the genetic and general model yield substantially different predictions for the distant kinship types in our data (cf. ancestor correlations reported in Tables G.5 and G.6). In particular, the genetic model with phenotypic assortment cannot explain why the kinship correlations in height remain non-negligible even for very distant siblings-in-law.

The results are therefore ambiguous. On the one hand, our approach yields parameter estimates that match well with estimates of the heritability of body height from quantitative genetics. On the other hand, the standard genetic model cannot explain why body height remains correlated between the most distant family members in our data. The genetic model fits a narrow set of kinship moments, but not the full set observed in this study. The potential culprit is the assumption that assortative mating occurs only in the phenotype. If spouses match on factors other than phenotype

height, and those other factors have an independent association with genotype height, then the standard genetic model understates the correlation between relatives – even if the intergenerational transmission process itself is exclusively due to genetic factors. The advantage of our approach is that such failures become visible: erroneous assumptions in the assortative process become noticeable among distant relatives even if they have only negligible implications for the close kinship correlations that have been studied in the previous literature.

H Additional Results: Spanish Census

We also calibrate our model for Spain, for which the intergenerational evidence has so far been quite limited (see for example Black and Devereux 2011). Because the available data sources do not report income for both parents and children, estimates of income mobility are based on a two-sample instrumental variable approach. The cross-country comparisons of educational mobility (Hertz et al. 2008, Blanden 2011) do not contain evidence for Spain either.⁶¹ We circumvent these data limitations by using *surnames* to identify kins in the complete-count 2001 Census from the Spanish region of Cantabria.⁶²

In contrast to the administrative registers from Sweden, the Census data are limited to a single cross-section, contain only educational outcomes and names, and lack direct family links to define kinship – allowing us to illustrate the feasibility of our approach in settings with scarce data. We exploit that children in Spain inherit surnames from both their parents to recover their family links. This naming convention allows us to track both maternal and paternal lines, and at around 36%, the match rates are far higher than the rates that have been achieved in Census data from other countries. As a consequence, we can compare a wide range of kinship correlations between Spain and Sweden, and distinguish how latent intergenerational, sibling, and assortative processes compare in the two countries.

H.1 Data

The 2001 population census for Spain, which is available nationwide, does not allow to identify families unless they are living in the same household. However, for the Spanish region of *Cantabria*

⁶¹Blanden (2011) demonstrates that the ranking of countries in terms of educational mobility and income mobility is quite similar, with a pair-wise correlation between the two type of measures of around 0.7. While our evidence pertains to education, it is therefore likely to be informative about the transmission of economic advantages more generally.

⁶²Other studies use names to consider intergenerational mobility on the surname level. For example, Collado et al. (2014) study multigenerational mobility in the 19th and the 20th century in Cantabria, while Güell et al. (2015) study intergenerational mobility in more recent data from Catalonia. In contrast to these studies, we use names to identify direct family relationships and to estimate individual-level processes.

we obtained information on the full name of each person, and we can use this information to identify parents and children. The Census also reports, among other variables, the gender, age and educational level of all individuals living in the region (526,339 persons). We define the t -generation as all persons born in Cantabria between 1956 and 1976 (71,479 males and 68,830 females) and the $(t - 1)$ -generation as their parents.

Matching. Surnames in Spain are passed from parents to children according to the following rule: A newborn person, regardless of gender, receives two surnames that are kept for life. The first surname is the father's first surname and the second the mother's first surname. This naming convention allows us to identify fathers and mothers. For each person i in generation t we define the set of potential parents as all the couples born before 1956 such that the husband first surname coincides with person i first surname and the wife first surname coincides with person i second surname. Then, we say that we identify the parents if there is only one couple in the set of potential parents and the age difference between both parents and the child is at least 16 years. We identify the parents for 25,860 males and 24,610 females, which is approximately 36.2% and 35.8% of the male and female population, respectively.

To assess how well our strategy to identify parents and children works, we exploit the fact that we can directly identify parents and children when they live together (without using surnames). We use this information to estimate the percentage of incorrect matchings derived from our identification strategy. We identify 51,923 parent-child pairs using the surnames, with 23,694 of these children co-residing with their (real) parents and 28,229 living in different households. For the sub-sample of children co-residing with their parents, the percentage of identification mistakes is 6.1%. We exclude these 1,453 pairs from our sample and the final sample size is 50,470. If the percentage of incorrect identifications for the sub-sample of parents-child not living together were also 6.1% we would expect 1,722 mistakes (3.4%) in the total sample.

Once we have identified parents and children, siblings are immediately identified, and when children are married we also identify siblings-in-law. Finally, we assume that siblings in the parents' generation are identified when there are at most four individuals in the over 25 population sharing the same two surnames. Once siblings in the parent generation are identified, uncles and nephews, and cousins are immediately identified. Again it is important to estimate how well our strategy to identify siblings in the parents' generation works. We cannot directly detect identification mistakes in the parent generation, but can test the reliability of our approach in the child generation. Specifically, we repeat the exercise to detect identification mistakes in the sample of co-residing children as described above, but restrict that sample to children with surnames held by between two and four individuals in the over 25 population. As expected, the percentage of incorrect identifications is now lower, 2.5%.

Education. We use the information on each individual's educational attainment and convert it to

Table H.1: Descriptive Statistics in Spanish Census

	Men				Women			
	Matched		Unmatched		Matched		Unmatched	
	Mean	Std. Dev	Mean	Std. Dev	Mean	Std. Dev	Mean	Std. Dev
Age	33.61	5.91	35.42	6.16	33.70	5.92	35.50	6.15
Years of schooling	10.53	3.71	9.71	3.64	10.99	3.71	10.11	3.69
Observations	25,860		45,619		24,610		44,220	

years of schooling following Calero et al. 2007.⁶³ We de-mean years of schooling using gender-birth-cohort averages. Table H.1 shows some basic descriptive statistics. The matched sample is almost two years younger than the unmatched one. The reason is that the older a person is, the more likely the parents are not living together or one of them has died. Since the matched sample is younger it is also more educated (0.8 more years of schooling than the unmatched sample).

H.2 Estimation results

H.2.1 Sample and calibrated moments

Table H.2 reports the sample correlation in years of schooling for each kinship, sorted from closely related to more distant kins. The first columns report the number of pairs and sample correlations. The pairs are weighted inversely by the square root of family size, as described in Section 3. We observe 65 distinct moments that can be classified into groups from very close kins (such as spouses, group I) to relatively distant kins (such as second-degree siblings-in-law, group X). Two kinship types that were not observed in the Swedish data are child-parents in-law (group III-b in Table H.2) and the Spouse of nephew/niece-uncle/aunt (group VII-b), as its child generation was too young for this definition to be meaningful. The sample sizes are much smaller than in the Swedish sources. They are still large enough for precise measurements of kinship types involving siblings and parents, but become noisy for the more distant types.

The kinship correlations in educational attainment tend to be slightly larger in our Spanish data than the corresponding moments for Sweden. For example, the brother correlation in years of schooling in Spain is 0.46, compared to 0.43 for Sweden. The gap is smaller for in-law and vertical kinships, and inverses for those moments that involve females in the parent generation (such as the mother-son or aunt-nephew relationships).

In our calibration we include all groups (including III-b and VII-b). We therefore use 65 distinct

⁶³We assign 2 years of education to those who did not complete primary education, 5 years to primary education, 8 to compulsory education, 10 to vocational training, 12 to secondary education, 15 to sort university degrees, 17 to long university degrees other than engineering and medicine, 18 for engineers and medical doctors and 19 for a Ph.D. All our results are robust to other reasonable ways to assign years of education as, for example, assigning 0 years of education to those who did not complete primary education, 4 years to primary education, 9 to vocational training and 11 to secondary education.

Table H.2: Sample and Predicted Moments in Spanish Census

Kinship		Data		Calibration		Kinship		Data		Calibration	
group	# name	# pairs	sample ρ	pred. ρ	% error	group	# name	# pairs	sample ρ	pred. ρ	% error
I	1 Spouses	24,819	0.543	0.569	4.7		...				
II	2 Brothers	11,109	0.464	0.464	0.0		30 Nephew-Uncle in-law (SM)	3,334	0.199	0.205	3.0
a^l - b	3 Sisters	10,316	0.420	0.425	1.2		31 Niece-Uncle in-law (SM)	3,067	0.168	0.183	8.5
	4 Brother-Sister	21,017	0.410	0.414	0.9	VII-b	24-b W-Nephew-Uncle (BF)	1,738	0.220	0.197	-10.1
III	5 Father-Son	25,860	0.385	0.369	-4.2	aa^l - b	25-b H-Niece-Uncle (BF)	1,930	0.192	0.191	-0.1
aa - a	6 Father-Daughter	24,610	0.335	0.321	-4.3		26-b W-Nephew-Uncle (BM)	1,737	0.213	0.198	-6.9
	7 Mother-Son	25,860	0.323	0.310	-4.2		27-b H-Niece-Uncle (BM)	1,873	0.224	0.210	-6.5
	8 Mother-Daughter	24,610	0.300	0.284	-5.3		28-b W-Nephew-Aunt (SF)	1,537	0.161	0.146	-9.1
III-b	5-b Son-Father in-law	13,191	0.276	0.262	-4.8		29-b H-Niece-Aunt (SF)	1,746	0.112	0.140	24.3
aa^l - a	6-b Daughter-Father in-law	11,628	0.265	0.280	5.7		30-b W-Nephew-Aunt (SM)	1,559	0.196	0.175	-10.9
	7-b Son-Mother in-law	13,191	0.225	0.245	8.7		31-b H-Niece-Aunt (SM)	1,648	0.176	0.185	4.8
	8-b Daughter-Mother in-law	11,628	0.219	0.236	7.7	VIII	32 Male Cousins (BF)	2,053	0.202	0.200	-1.0
IV	9 Brothers in-law (MF-M)	12,260	0.281	0.304	8.2	aa - bb	33 Male Cousins (SM)	1,779	0.200	0.214	7.0
a - b	10 Brother-Sister in-law (FM-M)	11,184	0.300	0.309	3.0		34 Male Cousins (SF)	3,752	0.209	0.189	-9.4
	11 Brother-Sister in-law (MF-F)	12,339	0.296	0.292	-1.2		35 Female Cousins (BF)	1,747	0.145	0.140	-3.5
	12 Sisters in-law (FM-F)	10,743	0.287	0.255	-10.9		36 Female Cousins (SM)	1,523	0.182	0.167	-8.1
V	13 Nephew-Uncle (BF)	3,787	0.237	0.258	8.6		37 Female Cousins (SF)	3,368	0.188	0.140	-25.4
aa - b	14 Niece-Uncle (BF)	3,487	0.201	0.219	9.0		38 Male-Female Cousins (BF)	3,817	0.187	0.167	-10.5
	15 Nephew-Uncle (BM)	3,602	0.241	0.257	6.7		39 Male-Female Cousins (SM)	3,364	0.192	0.189	-1.7
	16 Niece-Uncle (BM)	3,337	0.229	0.229	0.2		40 Male-Female Cousins (BM)	3,604	0.191	0.167	-12.6
	17 Nephew-Aunt (SF)	3,452	0.151	0.191	26.8		41 Male-Female Cousins (SF)	3,625	0.172	0.159	-7.8
	18 Niece-Aunt (SF)	3,253	0.140	0.164	16.9	IX	42 F-MF-M	3,045	0.159	0.158	-0.8
	19 Nephew-Aunt (SM)	3,334	0.221	0.227	2.9	a^l - c	43 F-MF-F	2,924	0.167	0.147	-11.8
	20 Niece-Aunt (SM)	3,067	0.181	0.204	12.3		44 F-FM-M	3,089	0.176	0.194	10.3
VI	21 Spouse of Sib. in-law (MF)	4,156	0.272	0.227	-16.5		45 M-MF-M	3,132	0.245	0.212	-13.3
a - b'	22 Spouse of Sib. in-law (FM)	3,296	0.249	0.221	-11.3	X	46 MF-MF-M	1,966	0.113	0.146	29.4
	23 Spouse of Sib. in-law (MM)	7,061	0.234	0.207	-11.6	a - c	47 MF-MF-F	1,950	0.072	0.133	84.2
VII	24 Nephew-Aunt in-law (BF)	3,787	0.175	0.201	14.9		48 MF-FM-M	2,009	0.181	0.166	-8.6
aa - b'	25 Niece-Aunt in-law (BF)	3,487	0.153	0.169	10.8		49 MF-FM-F	1,881	0.121	0.121	0.1
	26 Nephew-Aunt in-law (BM)	3,602	0.172	0.195	13.5		50 FM-MF-M	1,854	0.142	0.165	16.3
	27 Niece-Aunt in-law (BM)	3,337	0.163	0.173	6.1		51 FM-MF-F	1,807	0.134	0.149	11.2
	28 Nephew-Uncle in-law (SF)	3,452	0.192	0.178	-7.6		52 FM-FM-M	1,792	0.185	0.155	-16.1
	29 Niece-Uncle in-law (SF)	3,253	0.136	0.151	11.0		53 FM-FM-F	1,710	0.124	0.112	-9.7

Notes: Kinship correlations from Spanish Census data. See Table 3 for notation.

moments from 12 different kinship types. We calibrate the model as described in Section 3, and report the predicted moments as well as the percentage deviation between the observed and predicted moments in Table H.2. Overall, the calibrated model explains the data well. Figure H.1 illustrates the fit graphically, by plotting the sample moments and predicted moments from the calibrated model. For comparability, we plot the same 105 moments that are also plotted for our Swedish data in Figure 2. The mean absolute prediction error across all included moments is 9.9%. The prediction errors are therefore larger than in the Swedish data, consistent with the presence of sampling error from the smaller sample sizes.

The model however appears to fit the pattern of inequality transmission in Spain across vertical and horizontal kins, and across both direct and in-law relationships. Given the more restricted set of moments and number of observations, this conclusion is not as well supported as for the case of Sweden. Nevertheless, two observations suggest that our results are robust. First, we demonstrated in the Swedish sample that the full model (including the different channels via which inequalities are transmitted) could be calibrated from a set of moments that was much more restrictive than the set available for Spain (see Section 4.6). Second, our findings for Spain appear not too sensitive to changes in the underlying set of moments or their weights.⁶⁴

⁶⁴Because educational attainment for females has been increasing rapidly in our observation period, its distribution is quite different in the parent and child generation. The main results remain however robust to excluding some moments that involve females in the parent generation, such as the mother in-law or aunt. Our results are also robust to dropping distant kinships types for which sample sizes become very small, or to weight moments by the square root of the sample size (results available upon request).

Figure H.1: Fit in Spanish Census

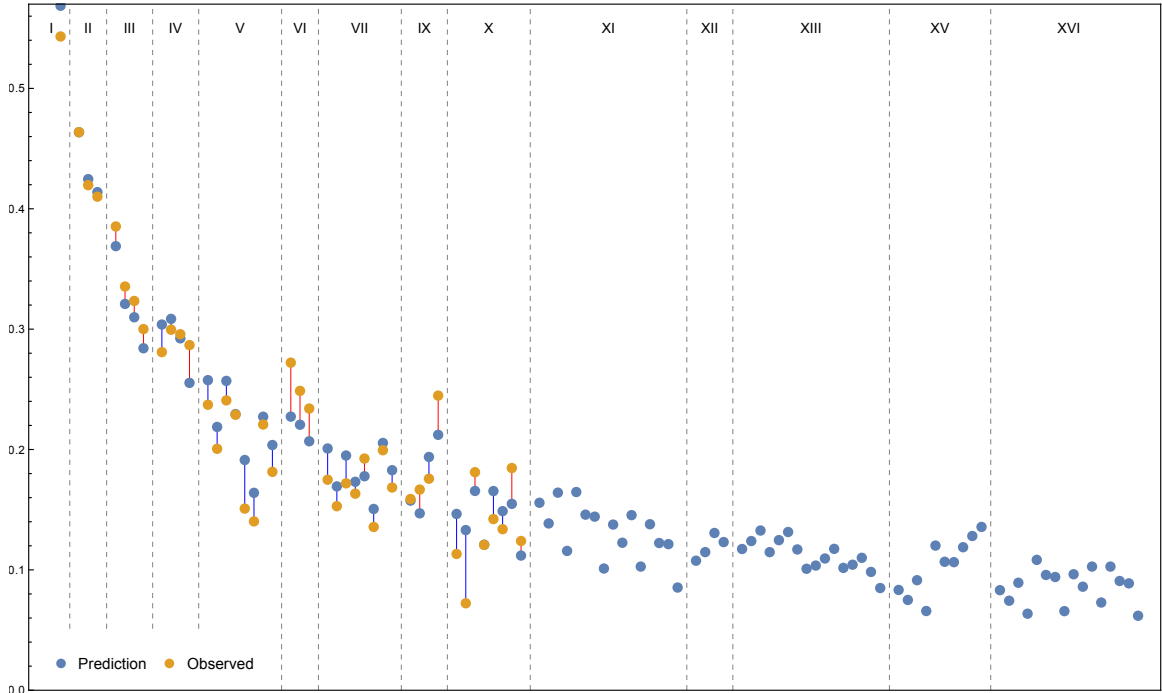

Notes: See Table H.2 for the corresponding list of kinship moments.

H.2.2 Intergenerational transmission

Panel A of Table H.3 reports the calibrated parameters for the intergenerational or “vertical” transmission in Spain. We again find that the direct transmission channels captured by the parameter β^k contribute very little to the transmission of educational inequalities. At $\hat{\beta}^m = 0.03$ and $\hat{\beta}^f = 0.11$ the estimates are close to the corresponding estimates for Sweden. Only about 1% of the variation in years of schooling is directly explained by parental education (panel D of Table H.3).

As for Sweden, the transmission of advantages occurs predominantly via the latent factor. At $\hat{\gamma}^m = 0.92$ and $\hat{\gamma}^f = 0.84$, the rate by which this latent factor is transmitted from parents to children is substantially higher in Spain than in Sweden.⁶⁵ As a consequence, the implied correlations in the latent status between parents and children are also much higher (about 30% higher), and decay more slowly across generations in Spain than in Sweden. For example, the implied correlation in educational attainment between children and their great-great-grandfathers is more than twice as large in Spain (0.16 vs. 0.07, Panel A of Tables 4 and H.3).

In sum, these results have three implications. First, the pattern of inequality transmission in Spain and Sweden are qualitatively similar, with the transmission of advantages occurring predominantly

⁶⁵The share of variance explained by the latent factor is similar as in Sweden for men, but much lower for women. One potential explanation for this pattern could be that secular trends in females’ educational attainment were stronger in Spain, such that less of the total variation in educational attainment is explained by individual- and family-specific factors.

Table H.3: Calibrated Parameters in Spanish Census

<i>Panel A: Intergenerational Processes</i>							
β^m	β^f	γ^m	γ^f	σ_{ym}^2	σ_{yf}^2	σ_{zm}^2	σ_{zf}^2
0.027	0.111	0.915	0.842	13.579	13.213	6.525	2.783
a_{ym}	a_{yf}	a_{zm}	a_{zf}	σ_{um}^2	σ_{uf}^2		
0.746	0.856	0.586	0.127	5.159	7.001		
<i>Ancestor correlations in y and z:</i>							
	Father-Son	Fr.-Daughter	Mother-Son	Mother-Daughter			
<i>in z</i>	0.760	0.827	0.732	0.883			
	Father-Son	Grandfr.-Son	GGrandfr.-Son	GGGrandfr.-Son			
<i>in y</i>	0.369	0.271	0.205	0.156			
<i>in z</i>	0.760	0.594	0.451	0.343			
<i>Panel B: Sibling Processes</i>							
	σ_{xm}^2	σ_{xf}^2	σ_{xmf}	σ_{em}^2	σ_{ef}^2	σ_{emef}	
	1.648	2.643	2.087	0.559	0.001	0.018	
<i>Sibling correlations in y and z:</i>							
	Brothers	Sisters	Mixed		Brothers	Sisters	Mixed
<i>in y</i>	0.464	0.425	0.414		0.674	0.784	0.666
<i>Panel C: Assortative Processes</i>							
r_{zz}^m	r_{zy}^m	r_{yz}^m	r_{yy}^m	r_{zz}^f	r_{zy}^f	r_{yz}^f	r_{yy}^f
0.732	-0.139	0.418	0.356	1.291	0.083	0.576	0.441
<i>Spousal correlations in y and z:</i>							
ρ_{ymyf}	ρ_{zmzf}	ρ_{ymzf}	ρ_{zmyf}				
0.569	0.903	0.483	0.549				
<i>Panel D: Variance Decomposition of y</i>							
	\tilde{y}_{t-1}	\tilde{z}_{t-1}	$\sigma_{\tilde{y}\tilde{z}}$	$\Sigma_{\tilde{y},\tilde{z}}$	x_t	e_t	$\Sigma_{\tilde{y},\tilde{z},x,e}$
<i>male</i>	0.1%	28.3%	1.8%	30.1%	12.1%	4.1%	46.4%
<i>female</i>	1.1%	16.5%	4.8%	22.5%	20.0%	0.0%	42.5%

Notes: Panels A and B report parameter estimates and implied ancestor and sibling correlations in educational attainment y and latent advantages z . The parameters β and σ_y^2 capture the direct transmission and variance of y ; γ and σ_z^2 the transmission and variance of z ; and σ_x^2 and σ_e^2 shared sibling influences in y and z ; see equations (1)-(3) for details. Panel C reports the coefficients from the linear projections (4) and (5) of z^k and y^k for $k = f, m$ on their spouse's z and y and the implied spousal correlations. Panel D decomposes σ_y^2 into the components explained by the parents' y (\tilde{y}_{t-1}) and z (\tilde{z}_{t-1}) and their covariance ($\sigma_{\tilde{y}\tilde{z}}$), and the sibling components in y (x_t) and z (e_t); $\Sigma_{\tilde{y}\tilde{z}}$ and $\Sigma_{\tilde{y},\tilde{z},x,e}$ are the total percentages explained by the parents and the close family (parental and shared sibling influences), respectively. Based on the kinship correlations reported in Table H.2.

via latent variables, with only a minor direct influence of parental education itself. Second, the stronger transmission of educational inequalities in Spain is explained by stronger transmission in the latent factor, i.e. is due to fundamental differences in the extent of status transmission. Third, standard measures understate the difference in mobility rates between Sweden and Spain. While parent-child and sibling correlations are only slightly larger in Spain, the gap is greater for more distant relatives.

H.2.3 Siblings and horizontal transmission

Panel B of Table H.3 summarizes our findings that pertain to siblings, which quantify what siblings share over and above the average rate of intergenerational transmission discussed in the previous section. As in the Swedish data, siblings must be far more similar to each other than what is captured by sibling correlations in years of education. For Spain, the implied correlation in the latent status between siblings are around 0.7 or higher, about 50% larger than the sibling correlation in years of education. The similarity in siblings in observable and latent characteristics captured by x^k and e^k explains between 15% (brothers and mixed pairs) and 20% (sisters) of the variation in educational attainment.

The degree to which siblings are subject to common influences is therefore similar in Spain as in Sweden. However, in Spain, most of this similarity is explained by the shared sibling influences in the observable outcome (x^k), while shared influences in the latent factor (e_t^k) are less important. The variance shares explained by x^k are more than three times larger than the corresponding variance shares for Sweden. One potential explanation could be location-specific shocks and trends: because siblings grow up in the same area, structural changes in the local provision of schooling would tend to be reflected in this component. Spain may have experienced more such changes in our analysis period, which would contribute to the sibling correlation in educational attainment. Because we lack distant kinships in the Spanish data, it is however difficult to distinguish the two types of sibling components.

H.2.4 Assortative mating

The calibrated parameter values for both the observed and latent dimensions of assortative mating in Spain are summarized in Panel C of Table H.3. Spousal correlations in years of schooling are around 0.54 in our Spanish sources, about 10% higher than the corresponding moment in the Swedish registers. As was the case for Sweden, the latent status of the mother is predominantly explained by the latent status of the father, while his educational attainment has no additional predictive power. However, the father's education has a substantial association with maternal education, over and above what can be explained by the father's latent factor. The corresponding projection matrix for females is similar.

The implied spousal correlations in the outcome y and the latent factor z are reported in the last block of Panel C. The first entry is simply the calibrated spousal correlation in educational attainment, which at $\rho_{y^m y^f} = 0.57$ is similar to its sample counterpart. In contrast, the implied spousal correlation in the latent factor is substantially higher. At $\rho_{z^m z^f} = 0.90$, it is also more than 10% higher than the corresponding estimate for Sweden. Our results, therefore, suggest stronger assortative mating in Spain compared to Sweden – not only in educational attainment, but also

in the latent determinants of socioeconomic status. Spouses in Spain appear very similar in those factors that ultimately determine the educational attainment of their descendants.

Additional References

- Behrman, J., and M. Rosenzweig (2002): “Does Increasing Women’s Schooling Raise the Schooling of the Next Generation?,” *American Economic Review*, 92(1), 323–334.
- Black, S. E., and P. Devereux (2011): “Recent Developments in Intergenerational Mobility,” in *Handbook of Labor Economics*, ed. by O. Ashenfelter, and D. Card, vol. 4A. Elsevier.
- Blanden, J. (2011): “Cross-Country Rankings in Intergenerational Mobility: A Comparison of Approaches from Economics and Sociology,” *Journal of Economic Surveys*.
- Calero, J., J. O. Escardíbul, S. Waisgrais, and M. Mediavilla (2007): “Desigualdades socioeconómicas en el sistema educativo español,” Discussion paper, Secretaría General Técnica. Centro de Publicaciones. Ministerio de Educación y Ciencia.
- Collado, M. D., I. Ortuño-Ortín, and A. Romeu (2014): “Long-run Intergenerational Social Mobility and the Distribution of Surnames,” Discussion Paper 2, UMUFAE Economics Working Papers.
- Galton, F. (1886): “Regression Towards Mediocrity in Hereditary Stature,” *The Journal of the Anthropological Institute of Great Britain and Ireland*, 15, 246–263.
- Grönqvist, E., B. Öckert, and J. Vlachos (2017): “The Intergenerational Transmission of Cognitive and Noncognitive Abilities,” *Journal of Human Resources*, 52(4), 887–918.
- Hertz, T., T. Jayasundera, P. Piraino, S. Selcuk, N. Smith, and A. Verashchagina (2008): “The Inheritance of Educational Inequality: International Comparisons and Fifty-Year Trends,” *The B.E. Journal of Economic Analysis & Policy*, 7(2), 1–48.
- Price, Richard A, and Steven G Vandenberg. 1980. “Spouse Similarity in American and Swedish Couples.” *Behavior genetics*, 10(1): 59–71
- Silventoinen, K. (2003): “Determinants of Variation in Adult Body Height,” *Journal of Biosocial Science*, 35(2), 263–285.
- Tambs, Kristian, Torbjørn Moum, Lindon J. Eaves, Mike C. Neale, Kristian Midthjell, Per G. Lund-Larsen, and Siri Næss. 1992. “Genetic and Environmental Contributions to the Variance of Body Height in a Sample of First and Second Degree Relatives.” *American Journal of Physical Anthropology*, 88(3): 285–294.

Estimating Intergenerational and Assortative Processes in Extended Family Data:

Additional Derivations

I	The General Model	2
I.1	Assortative mating process	2
I.2	Steady state assumption	4
I.3	Covariances	5
J	No Direct Effect and Assortative Mating Only in z	10
J.1	Assortative mating process	10
J.2	Covariances	12
J.3	Correlations	15
J.4	Identification	16
K	The Reduced Form Model	19
L	The Genetic Model	21
L.1	Assortative mating process	21
L.2	Covariances	22
L.3	Genetic transmission	24
M	The General Model with Two Unobservable Factors	28
M.1	Assortative mating process	28
M.2	Steady state assumption	31
M.3	Main covariances	33
M.4	Other covariances	35

I The General Model

We assume that the value of the outcome y for an individual from generation t is given by

$$y_t^k = \beta^k \tilde{y}_{t-1}^k + z_t^k + x_t^k + u_t^k \quad (\text{I.1})$$

where the superscript $k = m$ stands for males and $k = f$ for females. We assume that

$$\tilde{y}_{t-1}^k = \alpha_y^k y_{t-1}^m + (1 - \alpha_y^k) y_{t-1}^f$$

and the socioeconomic status of the child, z_t^k , depends on the father z_{t-1}^m as well as on the mother z_{t-1}^f

$$\begin{aligned} z_t^k &= \gamma^k \tilde{z}_{t-1}^k + e_t^k + v_t^k \\ \tilde{z}_{t-1}^k &= \alpha_z^k z_{t-1}^m + (1 - \alpha_z^k) z_{t-1}^f \end{aligned} \quad (\text{I.2})$$

Regarding the shocks, we assume that x_t^k and e_t^k are shared by all siblings of the same gender, can be correlated across siblings of different gender and are uncorrelated to each other and with the other variables (in particular with z_{t-1}^k and y_{t-1}^l , $l = m, f$). Finally u_t^k and v_t^k are white-noise errors.

We assume throughout the appendix that the economy is in the steady state, and therefore all the parameters and the moments of all the variables are time invariant.

I.1 Assortative mating process

We assume there is assortative mating both in years of schooling and in socioeconomic status (see Behrman and Rosenzweig, 2002, for a related model with assortative mating in two dimensions). In particular we consider the linear projections of z_{t-1}^f and y_{t-1}^f on z_{t-1}^m and y_{t-1}^m :

$$\begin{aligned} z_{t-1}^f &= r_{zz}^m z_{t-1}^m + r_{zy}^m y_{t-1}^m + w_{t-1}^m \\ y_{t-1}^f &= r_{yz}^m z_{t-1}^m + r_{yy}^m y_{t-1}^m + \varepsilon_{t-1}^m \end{aligned}$$

where w_{t-1}^m and ε_{t-1}^m might be correlated but are uncorrelated with z_{t-1}^m and y_{t-1}^m .

The coefficients of the linear projections depend on the correlations $\rho_{z^m y^m}$, $\rho_{z^m z^f}$, $\rho_{z^m y^f}$, $\rho_{y^m z^f}$ and $\rho_{y^m y^f}$, as well as on the standard deviations of z_{t-1}^k and y_{t-1}^k , $k = m, f$:

$$\begin{aligned} r_{zz}^m &= \frac{1}{(1 - \rho_{z^m y^m}^2)} \frac{\sigma_{z^f}}{\sigma_{z^m}} (\rho_{z^m z^f} - \rho_{z^m y^m} \rho_{y^m z^f}) \\ r_{zy}^m &= \frac{1}{(1 - \rho_{z^m y^m}^2)} \frac{\sigma_{z^f}}{\sigma_{y^m}} (\rho_{y^m z^f} - \rho_{z^m y^m} \rho_{z^m z^f}) \\ r_{yz}^m &= \frac{1}{(1 - \rho_{z^m y^m}^2)} \frac{\sigma_{y^f}}{\sigma_{z^m}} (\rho_{z^m y^f} - \rho_{z^m y^m} \rho_{y^m y^f}) \end{aligned}$$

$$r_{yy}^m = \frac{1}{(1 - \rho_{z^m y^m}^2)} \frac{\sigma_{y^f}}{\sigma_{y^m}} (\rho_{y^m y^f} - \rho_{z^m y^m} \rho_{z^m y^f})$$

We use these matching functions to write years of schooling, y_t^k , and social status, z_t^k , as a function of father's years of schooling, y_{t-1}^m , and social status z_{t-1}^m . We can write (I.2) as

$$z_t^k = G_{zm}^k z_{t-1}^m + G_{ym}^k y_{t-1}^m + g_m^k \omega_{t-1}^m + e_t^k + v_t^k$$

where

$$\begin{aligned} G_{zm}^k &= \gamma^k (\alpha_z^k + (1 - \alpha_z^k) r_{zz}^m) \\ G_{ym}^k &= \gamma^k (1 - \alpha_z^k) r_{zy}^m \\ g_m^k &= \gamma^k (1 - \alpha_z^k) \end{aligned}$$

and (I.1) as

$$y_t^k = B_{ym}^k y_{t-1}^m + B_{zm}^k z_{t-1}^m + b_m^k \varepsilon_{t-1}^m + g_m^k \omega_{t-1}^m + e_t^k + v_t^k + x_t^k + u_t^k$$

where

$$\begin{aligned} B_{ym}^k &= \beta^k (\alpha_y^k + (1 - \alpha_y^k) r_{yy}^m) + G_{ym}^k \\ B_{zm}^k &= \beta^k (1 - \alpha_y^k) r_{yz}^m + G_{zm}^k \\ b_m^k &= \beta^k (1 - \alpha_y^k) \end{aligned}$$

All these expressions will be used to compute correlations between relatives that are related through their fathers. However, when we consider relatives that are related through their mothers, we need to find expressions for y_t^k and z_t^k as functions of mother's years of schooling, y_{t-1}^f , and social status z_{t-1}^f . We then also consider the linear projections of z_{t-1}^m and y_{t-1}^m on z_{t-1}^f and y_{t-1}^f :

$$\begin{aligned} z_{t-1}^m &= r_{zz}^f z_{t-1}^f + r_{zy}^f y_{t-1}^f + w_{t-1}^f \\ y_{t-1}^m &= r_{yz}^f z_{t-1}^f + r_{yy}^f y_{t-1}^f + \varepsilon_{t-1}^f \end{aligned}$$

where w_{t-1}^f and ε_{t-1}^f might be correlated but are uncorrelated with z_{t-1}^f and y_{t-1}^f .

The coefficients of the linear projections depend on $\rho_{z^f y^f}$, $\rho_{z^m z^f}$, $\rho_{z^m y^f}$, $\rho_{y^m z^f}$ and $\rho_{y^m y^f}$, as well as on the standard deviations of z_{t-1}^k and y_{t-1}^k , $k = m, f$:

$$\begin{aligned} r_{zz}^f &= \frac{1}{(1 - \rho_{z^f y^f}^2)} \frac{\sigma_{z^m}}{\sigma_{z^f}} (\rho_{z^m z^f} - \rho_{z^f y^f} \rho_{z^m y^f}) \\ r_{zy}^f &= \frac{1}{(1 - \rho_{z^f y^f}^2)} \frac{\sigma_{z^m}}{\sigma_{y^f}} (\rho_{z^m y^f} - \rho_{z^f y^f} \rho_{z^m z^f}) \end{aligned}$$

$$r_{yz}^f = \frac{1}{(1 - \rho_{zf}^2 \rho_{yf}^2)} \frac{\sigma_{ym}}{\sigma_{zf}} (\rho_{ymzf} - \rho_{zf} \rho_{yf} \rho_{ymyf})$$

$$r_{yy}^f = \frac{1}{(1 - \rho_{zf}^2 \rho_{yf}^2)} \frac{\sigma_{ym}}{\sigma_{yf}} (\rho_{ymyf} - \rho_{zf} \rho_{yf} \rho_{ymzf})$$

Using these linear projections, we can write (I.2) as

$$z_t^k = G_{zf}^k z_{t-1}^f + G_{yf}^k y_{t-1}^f + g_f^k \omega_{t-1}^f + e_t^k + v_t^k$$

where

$$G_{zf}^k = \gamma^k (\alpha_z^k r_{zz}^f + (1 - \alpha_z^k))$$

$$G_{yf}^k = \gamma^k \alpha_z^k r_{zy}^f$$

$$g_f^k = \gamma^k \alpha_z^k$$

and (I.1) as

$$y_t^k = B_{yf}^k y_{t-1}^f + B_{zf}^k z_{t-1}^f + b_f^k \varepsilon_{t-1}^f + g_f^k \omega_{t-1}^f + e_t^k + v_t^k + x_t^k + u_t^k$$

where

$$B_{yf}^k = \beta^k (\alpha_y^k r_{yy}^f + (1 - \alpha_y^k)) + G_{yf}^k$$

$$B_{zf}^k = \beta^k \alpha_y^k r_{yz}^f + G_{zf}^k$$

$$b_f^k = \beta^k \alpha_y^k$$

I.2 Steady state assumption

As mentioned above, we assume that the second order moments of all variables are time invariant. This steady state assumption implies that $\rho_{z^m y^m}$ and $\rho_{zf yf}$ depend on the remaining parameters of the model as shown below.

$$\begin{aligned} Cov(y_t^m, z_t^m) &= Cov(\beta^m \tilde{y}_{t-1}^m + z_t^m, z_t^m) = Cov(\beta^m (\alpha_y^m y_{t-1}^m + (1 - \alpha_y^m) y_{t-1}^f), \gamma^m (\alpha_z^m z_{t-1}^m + (1 - \alpha_z^m) z_{t-1}^f)) + \sigma_{z^m}^2 \\ &= \beta^m \alpha_y^m \gamma^m \alpha_z^m Cov(y_{t-1}^m, z_{t-1}^m) + \beta^m \alpha_y^m \gamma^m (1 - \alpha_z^m) Cov(y_{t-1}^m, z_{t-1}^f) \\ &+ \beta^m (1 - \alpha_y^m) \gamma^m \alpha_z^m Cov(y_{t-1}^f, z_{t-1}^m) + \beta^m (1 - \alpha_y^m) \gamma^m (1 - \alpha_z^m) Cov(y_{t-1}^f, z_{t-1}^f) + \sigma_{z^m}^2 \end{aligned}$$

Dividing by σ_{z^m} and σ_{y^m} , we have

$$\begin{aligned} \rho_{z^m y^m} &= \beta^m \alpha_y^m \gamma^m \alpha_z^m \rho_{z^m y^m} + \beta^m \alpha_y^m \gamma^m (1 - \alpha_z^m) \frac{\sigma_{zf}}{\sigma_{z^m}} \rho_{y^m z^f} \\ &+ \beta^m (1 - \alpha_y^m) \gamma^m \alpha_z^m \frac{\sigma_{yf}}{\sigma_{y^m}} \rho_{z^m y^f} + \beta^m (1 - \alpha_y^m) \gamma^m (1 - \alpha_z^m) \frac{\sigma_{zf}}{\sigma_{z^m}} \frac{\sigma_{yf}}{\sigma_{y^m}} \rho_{z^f y^f} + \frac{\sigma_{z^m}}{\sigma_{y^m}} \end{aligned}$$

and rearranging

$$\begin{aligned} & (1 - \beta^m \alpha_y^m \gamma^m \alpha_z^m) \rho_{z^m y^m} - \beta^m (1 - \alpha_y^m) \gamma^m (1 - \alpha_z^m) \frac{\sigma_{zf}}{\sigma_{z^m}} \frac{\sigma_{yf}}{\sigma_{y^m}} \rho_{zf y^f} \\ = & \frac{\sigma_{z^m}}{\sigma_{y^m}} + \beta^m \alpha_y^m \gamma^m (1 - \alpha_z^m) \frac{\sigma_{zf}}{\sigma_{z^m}} \rho_{y^m z^f} + \beta^m (1 - \alpha_y^m) \gamma^m \alpha_z^m \frac{\sigma_{yf}}{\sigma_{y^m}} \rho_{z^m y^f} \end{aligned}$$

analogously

$$\begin{aligned} & -\beta^f (1 - \alpha_y^f) \gamma^f (1 - \alpha_z^f) \frac{\sigma_{z^m}}{\sigma_{zf}} \frac{\sigma_{y^m}}{\sigma_{yf}} \rho_{z^m y^m} + (1 - \beta^f \alpha_y^f \gamma^f \alpha_z^f) \rho_{zf y^f} \\ = & \frac{\sigma_{zf}}{\sigma_{yf}} + \beta^f \alpha_y^f \gamma^f (1 - \alpha_z^f) \frac{\sigma_{z^m}}{\sigma_{zf}} \rho_{z^m y^f} + \beta^f (1 - \alpha_y^f) \gamma^f \alpha_z^f \frac{\sigma_{y^m}}{\sigma_{yf}} \rho_{y^m z^f} \end{aligned}$$

and from these two equations we can solve for $\rho_{z^m y^m}$ and $\rho_{zf y^f}$ as a function of $\rho_{y^m z^f}$, $\rho_{z^m y^f}$ and some other parameters of the model.

We then have that the model has 20 parameters $\gamma^k, \beta^k, \alpha_z^k, \alpha_y^k, \sigma_{zk}^2, \sigma_{xk}^2, \sigma_{ek}^2$, $k = m, f$, and $\sigma_{x^m x^f}, \sigma_{e^m e^f}, \rho_{z^m z^f}, \rho_{y^m z^f}, \rho_{z^m y^f}$ and $\rho_{y^m y^f}$

I.3 Covariances

I.3.1 Main covariances

We use the notation in Figure 1 to denote individuals with different degrees of kinship. We first compute the main covariances (husband-wife, parent-child and siblings). Then, the covariances for other relatives are obtained recursively.

Husband and wife $a - a'$

We have to compute the covariance between "a" and "a'". Let $n' = m, f$ be the gender of a' and $n = m, f$ the gender of the a .

$$Cov(y_{t-1}^{a,n}, y_{t-1}^{a',n'}) = \sigma_{y^m} \sigma_{y^f} \rho_{y^m y^f}$$

Parent-child $aa - a'$

We have to compute the covariances between "aa" and "a'". Let $n' = m, f$ be the gender of a' and $n^* = m, f$ the gender of the aa . We project aa on a' (his/her father or mother) who has gender n'

$$\begin{aligned} Cov(z_t^{aa,n^*}, z_{t-1}^{a',n'}) &= Cov(G_{y^{n'}}^{n^*} y_{t-1}^{n'} + G_{z^{n'}}^{n^*} z_{t-1}^{n'}, z_{t-1}^{n'}) \\ &= G_{y^{n'}}^{n^*} \sigma_{z^{n'}} \sigma_{y^{n'}} \rho_{z^{n'} y^{n'}} + G_{z^{n'}}^{n^*} \sigma_{z^{n'}}^2 \end{aligned}$$

$$\begin{aligned} Cov(z_t^{aa,n^*}, y_{t-1}^{a',n'}) &= Cov(G_{y^{n'}}^{n^*} y_{t-1}^{n'} + G_{z^{n'}}^{n^*} z_{t-1}^{n'}, y_{t-1}^{n'}) \\ &= G_{y^{n'}}^{n^*} \sigma_{y^{n'}}^2 + G_{z^{n'}}^{n^*} \sigma_{z^{n'}} \sigma_{y^{n'}} \rho_{z^{n'} y^{n'}} \end{aligned}$$

$$\begin{aligned}
Cov(y_t^{aa,n^*}, z_{t-1}^{a',n'}) &= Cov(B_{y_{n'}}^{n^*} y_{t-1}^{n'} + B_{z_{n'}}^{n^*} z_{t-1}^{n'}, z_{t-1}^{n'}) \\
&= B_{y_{n'}}^{n^*} \sigma_{z_{n'}} \sigma_{y_{n'}} \rho_{z_{n'} y_{n'}} + B_{z_{n'}}^{n^*} \sigma_{z_{n'}}^2
\end{aligned}$$

$$\begin{aligned}
Cov(y_t^{aa,n^*}, y_{t-1}^{a',n'}) &= Cov(B_{y_{n'}}^{n^*} y_{t-1}^{n'} + B_{z_{n'}}^{n^*} z_{t-1}^{n'}, y_{t-1}^{n'}) \\
&= B_{y_{n'}}^{n^*} \sigma_{y_{n'}}^2 + B_{z_{n'}}^{n^*} \sigma_{z_{n'}} \sigma_{y_{n'}} \rho_{z_{n'} y_{n'}}
\end{aligned}$$

Siblings $a' - b$

We have to compute the covariances between "a'" and "b". Let $n' = m, f$ be the gender of a' and $l = m, f$ the gender of the b . We project a' and b on their father or mother $GP2$ who has gender k

$$\begin{aligned}
Cov(z_{t-1}^{a',n'}, z_{t-1}^{b,l}) &= Cov(G_{y_k}^{n'} y_{t-2}^{GP2,k} + G_{z_k}^{n'} z_{t-2}^{GP2,k} + g_k^{n'} \omega_{t-2}^k + e_{t-1}^{a',n'}, G_{y_k}^l y_{t-2}^{GP2,k} + G_{z_k}^l z_{t-2}^{GP2,k} + g_k^l \omega_{t-2}^k + e_{t-1}^{b,l}) \\
&= G_{y_k}^{n'} G_{y_k}^l \sigma_{y_k}^2 + G_{z_k}^{n'} G_{z_k}^l \sigma_{z_k}^2 + \left(G_{y_k}^{n'} G_{z_k}^l + G_{z_k}^{n'} G_{y_k}^l \right) \sigma_{z_{n'}} \sigma_{y_{n'}} \rho_{z_{n'} y_{n'}} \\
&+ g_k^{n'} g_k^l \sigma_{w^k}^2 + \sigma_{e_{n'} e^l}
\end{aligned}$$

$$\begin{aligned}
Cov(z_{t-1}^{a',n'}, y_{t-1}^{b,l}) &= Cov(G_{y_k}^{n'} y_{t-2}^{GP2,k} + G_{z_k}^{n'} z_{t-2}^{GP2,k} + g_k^{n'} \omega_{t-2}^k + e_{t-1}^{a',n'}, B_{y_k}^l y_{t-2}^{GP2,k} + B_{z_k}^l z_{t-2}^{GP2,k} + b_k^l \varepsilon_{t-2}^k + g_k^l \omega_{t-2}^k + e_{t-1}^{b,l}) \\
&= G_{y_k}^{n'} B_{y_k}^l \sigma_{y_k}^2 + G_{z_k}^{n'} B_{z_k}^l \sigma_{z_k}^2 + \left(G_{y_k}^{n'} B_{z_k}^l + G_{z_k}^{n'} B_{y_k}^l \right) \sigma_{z_{n'}} \sigma_{y_{n'}} \rho_{z_{n'} y_{n'}} \\
&+ g_k^{n'} g_k^l \sigma_{w^k}^2 + \sigma_{e_{n'} e^l} + g_k^{n'} b_k^l Cov(\varepsilon_{t-1}^k, \omega_{t-1}^k)
\end{aligned}$$

$$\begin{aligned}
Cov(y_{t-1}^{a',n'}, z_{t-1}^{b,l}) &= Cov(B_{y_k}^{n'} y_{t-2}^{GP2,k} + B_{z_k}^{n'} z_{t-2}^{GP2,k} + b_k^{n'} \varepsilon_{t-2}^{n'} + g_k^{n'} \omega_{t-2}^k + e_{t-1}^{a',n'}, G_{y_k}^l y_{t-2}^{GP2,k} + G_{z_k}^l z_{t-2}^{GP2,k} + g_k^l \omega_{t-2}^k + e_{t-1}^{b,l}) \\
&= B_{y_k}^{n'} G_{y_k}^l \sigma_{y_k}^2 + B_{z_k}^{n'} G_{z_k}^l \sigma_{z_k}^2 + \left(B_{y_k}^{n'} G_{z_k}^l + B_{z_k}^{n'} G_{y_k}^l \right) \sigma_{z_{n'}} \sigma_{y_{n'}} \rho_{z_{n'} y_{n'}} \\
&+ g_k^{n'} g_k^l \sigma_{w^k}^2 + \sigma_{e_{n'} e^l} + b_k^{n'} g_k^l Cov(\varepsilon_{t-1}^k, \omega_{t-1}^k)
\end{aligned}$$

$$\begin{aligned}
Cov(y_{t-1}^{a',n'}, y_{t-1}^{b,l}) &= Cov(B_{y_k}^{n'} y_{t-2}^{GP2,k} + B_{z_k}^{n'} z_{t-2}^{GP2,k} + b_k^{n'} \varepsilon_{t-2}^{n'} + g_k^{n'} \omega_{t-2}^k + e_{t-1}^{a',n'} + x_{t-1}^{a',n'}, B_{y_k}^l y_{t-2}^{GP2,k} + B_{z_k}^l z_{t-2}^{GP2,k} + b_k^l \varepsilon_{t-2}^k + g_k^l \omega_{t-2}^k + e_{t-1}^{b,l} + x_{t-1}^{b,l}) \\
&= B_{y_k}^{n'} B_{y_k}^l \sigma_{y_k}^2 + B_{z_k}^{n'} B_{z_k}^l \sigma_{z_k}^2 + \left(B_{y_k}^{n'} B_{z_k}^l + B_{z_k}^{n'} B_{y_k}^l \right) \sigma_{z_{n'}} \sigma_{y_{n'}} \rho_{z_{n'} y_{n'}} \\
&+ g_k^{n'} g_k^l \sigma_{w^k}^2 + b_k^{n'} b_k^l \sigma_{\varepsilon^k}^2 + \sigma_{e_{n'} e^l} + \left(b_k^{n'} g_k^l + g_k^{n'} b_k^l \right) Cov(\varepsilon_{t-1}^{n'}, \omega_{t-1}^{n'}) + \sigma_{x_{n'} x^l}
\end{aligned}$$

I.3.2 Other covariances

Before we obtain the remaining covariances for different degrees of kinship we compute the linear projections of $z_{t-1}^{a',n'}$ and $y_{t-1}^{a',n'}$ on $z_{t-1}^{b,l}$ and $y_{t-1}^{b,l}$, $n', l = m, f$, where a' and b are siblings

$$\begin{aligned}
z_{t-1}^{a',n'} &= r_{zz}^{n',l} z_{t-1}^{b,l} + r_{zy}^{n',l} y_{t-1}^{b,l} + w_{t-1}^{b,l} \\
y_{t-1}^{a',n'} &= r_{yz}^{n',l} z_{t-1}^{b,l} + r_{yy}^{n',l} y_{t-1}^{b,l} + \varepsilon_{t-1}^{b,l}
\end{aligned}$$

where $w_{t-1}^{b,l}$ and $\varepsilon_{t-1}^{b,l}$ might be correlated but are uncorrelated with $z_{t-1}^{b,l}$ and $y_{t-1}^{b,l}$ and

$$r_{zz}^{n',l} = \frac{1}{\sigma_{z^l}^2 \sigma_{y^l}^2 - \sigma_{z^l y^l}^2} \left(\sigma_{y^l}^2 \sigma_{z^{a'}, n'} \sigma_{z^{b,l}} - \sigma_{z^l y^l} \sigma_{z^{a'}, n'} \sigma_{y^{b,l}} \right)$$

$$r_{zy}^{n',l} = \frac{1}{\sigma_{z^l}^2 \sigma_{y^l}^2 - \sigma_{z^l y^l}^2} \left(\sigma_{z^l}^2 \sigma_{z^{a',n'} y^{b,l}} - \sigma_{z^l y^l} \sigma_{z^{a',n'} z^{b,l}} \right)$$

$$r_{yz}^{n',l} = \frac{1}{\sigma_{z^l}^2 \sigma_{y^l}^2 - \sigma_{z^l y^l}^2} \left(\sigma_{y^l}^2 \sigma_{y^{a',n'} z^{b,l}} - \sigma_{z^l y^l} \sigma_{y^{a',n'} y^{b,l}} \right)$$

$$r_{yy}^{n',l} = \frac{1}{\sigma_{z^l}^2 \sigma_{y^l}^2 - \sigma_{z^l y^l}^2} \left(\sigma_{z^l}^2 \sigma_{y^{a',n'} y^{b,l}} - \sigma_{z^l y^l} \sigma_{y^{a',n'} z^{b,l}} \right)$$

Notice that error terms, $w_{t-1}^{b,l}$ and $\varepsilon_{t-1}^{b,l}$, are likely to be correlated with the latent factor and the outcome of a , the spouse of a' , and also with error terms of the linear projections of a' on a . However, since we use these linear projections to find the correlation with in-law relatives of b , what is relevant is whether $w_{t-1}^{b,l}$ and $\varepsilon_{t-1}^{b,l}$ are correlated with $z_{t-1}^{b',l}$ and $y_{t-1}^{b',l}$, where b' is the spouse of b . Since these error terms are not correlated with $z_{t-1}^{b,l}$ and $y_{t-1}^{b,l}$, and we are assuming that the assortative mating is in z and y , they are not correlated with $z_{t-1}^{b',l}$ and $y_{t-1}^{b',l}$ either.

Consanguine relatives ("blood")

Vertical covariances

Uncle/aunt (siblings of the parents) $aa - b$

We have to compute the covariances between "aa" and "b". Let $n^* = m, f$ be the gender of aa and $l = m, f$ the gender of the b . We project aa on a' (his/her father or mother) who has gender n'

$$Cov(z_t^{aa,n^*}, z_{t-1}^{b,l}) = Cov(G_{zn'}^* z_{t-1}^{a',n'} + G_{yn'}^* y_{t-1}^{a',n'}, z_{t-1}^{b,l}) = G_{zn'}^* Cov(z_{t-1}^{a',n'}, z_{t-1}^{b,l}) + G_{yn'}^* Cov(y_{t-1}^{a',n'}, z_{t-1}^{b,l})$$

$$Cov(z_t^{aa,n^*}, y_{t-1}^{b,l}) = Cov(G_{zn'}^* z_{t-1}^{a',n'} + G_{yn'}^* y_{t-1}^{a',n'}, y_{t-1}^{b,l}) = G_{zn'}^* Cov(z_{t-1}^{a',n'}, y_{t-1}^{b,l}) + G_{yn'}^* Cov(y_{t-1}^{a',n'}, y_{t-1}^{b,l})$$

$$Cov(y_t^{aa,n^*}, z_{t-1}^{b,l}) = Cov(B_{zn'}^* z_{t-1}^{a',n'} + B_{yn'}^* y_{t-1}^{a',n'}, z_{t-1}^{b,l}) = B_{zn'}^* Cov(z_{t-1}^{a',n'}, z_{t-1}^{b,l}) + B_{yn'}^* Cov(y_{t-1}^{a',n'}, z_{t-1}^{b,l})$$

$$Cov(y_t^{aa,n^*}, y_{t-1}^{b,l}) = Cov(B_{zn'}^* z_{t-1}^{a',n'} + B_{yn'}^* y_{t-1}^{a',n'}, y_{t-1}^{b,l}) = B_{zn'}^* Cov(z_{t-1}^{a',n'}, y_{t-1}^{b,l}) + B_{yn'}^* Cov(y_{t-1}^{a',n'}, y_{t-1}^{b,l})$$

where a' and b are siblings.

Horizontal covariances

Cousins $aa - bb$

We have to compute the covariances between "aa" and "bb". Let $n^* = m, f$ be the gender of aa and $l^* = m, f$ the gender of the bb . We project bb on b (his/her father or mother) who has gender l

$$Cov(z_t^{aa,n^*}, z_t^{bb,l^*}) = Cov(z_t^{aa,n^*}, G_{zl}^* z_{t-1}^{b,l} + G_{yl}^* y_{t-1}^{b,l}) = G_{zl}^* Cov(z_t^{aa,n^*}, z_{t-1}^{b,l}) + G_{yl}^* Cov(z_t^{aa,n^*}, y_{t-1}^{b,l})$$

$$Cov(z_t^{aa,n^*}, y_t^{bb,l^*}) = Cov(z_t^{aa,n^*}, B_{zl}^* z_{t-1}^{b,l} + B_{yl}^* y_{t-1}^{b,l}) = B_{zl}^* Cov(z_t^{aa,n^*}, z_{t-1}^{b,l}) + B_{yl}^* Cov(z_t^{aa,n^*}, y_{t-1}^{b,l})$$

$$Cov(y_t^{aa,n^*}, z_t^{bb,l^*}) = Cov(y_t^{aa,n^*}, G_{zl}^* z_{t-1}^{b,l} + G_{yl}^* y_{t-1}^{b,l}) = G_{zl}^* Cov(y_t^{aa,n^*}, z_{t-1}^{b,l}) + G_{yl}^* Cov(y_t^{aa,n^*}, y_{t-1}^{b,l})$$

$$Cov(y_t^{aa,n^*}, y_t^{bb,l^*}) = Cov(y_t^{aa,n^*}, B_{zl}^{l^*} z_{t-1}^{b,l} + B_{yl}^{l^*} y_{t-1}^{b,l}) = B_{zl}^{l^*} Cov(y_t^{aa,n^*}, z_{t-1}^{b,l}) + B_{yl}^{l^*} Cov(y_t^{aa,n^*}, y_{t-1}^{b,l})$$

where b is the uncle/aunt of aa .

Affinity relatives ("in-law")

Vertical covariances

Spouse of the uncle/aunt (spouses of the siblings of the parents) $aa - b'$

We have to compute the covariances between " aa " and " b' ". Let $n^* = m, f$ be the gender of aa and $l' = m, f$ the gender of the b' . We project b' on his/her spouse b who has gender l

$$Cov(z_t^{aa,n^*}, z_{t-1}^{b',l'}) = Cov(z_t^{aa,n^*}, r_{zz}^l z_{t-1}^{b,l} + r_{zy}^l y_{t-1}^{b,l}) = r_{zz}^l Cov(z_t^{aa,n^*}, z_{t-1}^{b,l}) + r_{zy}^l Cov(z_t^{aa,n^*}, y_{t-1}^{b,l})$$

$$Cov(z_t^{aa,n^*}, y_{t-1}^{b',l'}) = Cov(z_t^{aa,n^*}, r_{yz}^l z_{t-1}^{b,l} + r_{yy}^l y_{t-1}^{b,l}) = r_{yz}^l Cov(z_t^{aa,n^*}, z_{t-1}^{b,l}) + r_{yy}^l Cov(z_t^{aa,n^*}, y_{t-1}^{b,l})$$

$$Cov(y_t^{aa,n^*}, z_{t-1}^{b',l'}) = Cov(y_t^{aa,n^*}, r_{zz}^l z_{t-1}^{b,l} + r_{zy}^l y_{t-1}^{b,l}) = r_{zz}^l Cov(y_t^{aa,n^*}, z_{t-1}^{b,l}) + r_{zy}^l Cov(y_t^{aa,n^*}, y_{t-1}^{b,l})$$

$$Cov(y_t^{aa,n^*}, y_{t-1}^{b',l'}) = Cov(y_t^{aa,n^*}, r_{yz}^l z_{t-1}^{b,l} + r_{yy}^l y_{t-1}^{b,l}) = r_{yz}^l Cov(y_t^{aa,n^*}, z_{t-1}^{b,l}) + r_{yy}^l Cov(y_t^{aa,n^*}, y_{t-1}^{b,l})$$

where b is uncle/aunt of aa .

Siblings of the siblings in law of the parents $aa - c$

We have to compute the covariances between " aa " and " c ". Let $n^* = m, f$ be the gender of aa and $o = m, f$ the gender of the c . We project c on his/her sibling b' who has gender l'

$$Cov(z_t^{aa,n^*}, z_{t-1}^{c,o}) = Cov(z_t^{aa,n^*}, r_{zz}^{o,l'} z_{t-1}^{b',l'} + r_{zy}^{o,l'} y_{t-1}^{b',l'}) = r_{zz}^{o,l'} Cov(z_t^{aa,n^*}, z_{t-1}^{b',l'}) + r_{zy}^{o,l'} Cov(z_t^{aa,n^*}, y_{t-1}^{b',l'})$$

$$Cov(z_t^{aa,n^*}, y_{t-1}^{c,o}) = Cov(z_t^{aa,n^*}, r_{yz}^{o,l'} z_{t-1}^{b',l'} + r_{yy}^{o,l'} y_{t-1}^{b',l'}) = r_{yz}^{o,l'} Cov(z_t^{aa,n^*}, z_{t-1}^{b',l'}) + r_{yy}^{o,l'} Cov(z_t^{aa,n^*}, y_{t-1}^{b',l'})$$

$$Cov(y_t^{aa,n^*}, z_{t-1}^{c,o}) = Cov(y_t^{aa,n^*}, r_{zz}^{o,l'} z_{t-1}^{b',l'} + r_{zy}^{o,l'} y_{t-1}^{b',l'}) = r_{zz}^{o,l'} Cov(y_t^{aa,n^*}, z_{t-1}^{b',l'}) + r_{zy}^{o,l'} Cov(y_t^{aa,n^*}, y_{t-1}^{b',l'})$$

$$Cov(y_t^{aa,n^*}, y_{t-1}^{c,o}) = Cov(y_t^{aa,n^*}, r_{yz}^{o,l'} z_{t-1}^{b',l'} + r_{yy}^{o,l'} y_{t-1}^{b',l'}) = r_{yz}^{o,l'} Cov(y_t^{aa,n^*}, z_{t-1}^{b',l'}) + r_{yy}^{o,l'} Cov(y_t^{aa,n^*}, y_{t-1}^{b',l'})$$

where b' is the spouse of the uncle/aunt of aa .

We can recursively compute the covariances for the spouses of the siblings in law of the parents and the siblings of the siblings in law of the parents of any degree.

Horizontal covariances

Siblings in law $a - b$

We have to compute the covariances between " a " and " b ". Let $n = m, f$ be the gender of a and $l = m, f$ the

gender of the b . We project a on his/her spouse a' who has gender n'

$$Cov(z_{t-1}^{a,n}, z_{t-1}^{b,l}) = Cov(r_{zz}^{n'} z_{t-1}^{a',n'} + r_{zy}^{n'} y_{t-1}^{a',n'}, z_{t-1}^{b,l}) = r_{zz}^{n'} Cov(z_{t-1}^{a',n'}, z_{t-1}^{b,l}) + r_{zy}^{n'} Cov(y_{t-1}^{a',n'}, z_{t-1}^{b,l})$$

$$Cov(z_{t-1}^{a,n}, y_{t-1}^{b,l}) = Cov(r_{zz}^{n'} z_{t-1}^{a',n'} + r_{zy}^{n'} y_{t-1}^{a',n'}, y_{t-1}^{b,l}) = r_{zz}^{n'} Cov(z_{t-1}^{a',n'}, y_{t-1}^{b,l}) + r_{zy}^{n'} Cov(y_{t-1}^{a',n'}, y_{t-1}^{b,l})$$

$$Cov(y_{t-1}^{a,n}, z_{t-1}^{b,l}) = Cov(r_{yz}^{n'} z_{t-1}^{a',n'} + r_{yy}^{n'} y_{t-1}^{a',n'}, z_{t-1}^{b,l}) = r_{yz}^{n'} Cov(z_{t-1}^{a',n'}, z_{t-1}^{b,l}) + r_{yy}^{n'} Cov(y_{t-1}^{a',n'}, z_{t-1}^{b,l})$$

$$Cov(y_{t-1}^{a,n}, y_{t-1}^{b,l}) = Cov(r_{yz}^{n'} z_{t-1}^{a',n'} + r_{yy}^{n'} y_{t-1}^{a',n'}, y_{t-1}^{b,l}) = r_{yz}^{n'} Cov(z_{t-1}^{a',n'}, y_{t-1}^{b,l}) + r_{yy}^{n'} Cov(y_{t-1}^{a',n'}, y_{t-1}^{b,l})$$

where a' and b are siblings.

Spouse of the siblings in law $a - b'$

We have to compute the covariances between " a " and " b' ". Let $n = m, f$ be the gender of a and $l' = m, f$ the gender of the b' . We project b' on his/her spouse b

$$Cov(z_{t-1}^{a,n}, z_{t-1}^{b',l'}) = Cov(z_{t-1}^{a,n}, r_{zz}^l z_{t-1}^{b,l} + r_{zy}^l y_{t-1}^{b,l}) = r_{zz}^l Cov(z_{t-1}^{a,n}, z_{t-1}^{b,l}) + r_{zy}^l Cov(z_{t-1}^{a,n}, y_{t-1}^{b,l})$$

$$Cov(z_{t-1}^{a,n}, y_{t-1}^{b',l'}) = Cov(z_{t-1}^{a,n}, r_{yz}^l z_{t-1}^{b,l} + r_{yy}^l y_{t-1}^{b,l}) = r_{yz}^l Cov(z_{t-1}^{a,n}, z_{t-1}^{b,l}) + r_{yy}^l Cov(z_{t-1}^{a,n}, y_{t-1}^{b,l})$$

$$Cov(y_{t-1}^{a,n}, z_{t-1}^{b',l'}) = Cov(y_{t-1}^{a,n}, r_{zz}^l z_{t-1}^{b,l} + r_{zy}^l y_{t-1}^{b,l}) = r_{zz}^l Cov(y_{t-1}^{a,n}, z_{t-1}^{b,l}) + r_{zy}^l Cov(y_{t-1}^{a,n}, y_{t-1}^{b,l})$$

$$Cov(y_{t-1}^{a,n}, y_{t-1}^{b',l'}) = Cov(y_{t-1}^{a,n}, r_{yz}^l z_{t-1}^{b,l} + r_{yy}^l y_{t-1}^{b,l}) = r_{yz}^l Cov(y_{t-1}^{a,n}, z_{t-1}^{b,l}) + r_{yy}^l Cov(y_{t-1}^{a,n}, y_{t-1}^{b,l})$$

where a and b are siblings in law.

Sibling of the sibling in law

We have to compute the covariances between " a' " and " c ". Let $n' = m, f$ be the gender of a' and $o = m, f$ the gender of the c . We project a' on his/her sibling b who has gender l

$$Cov(z_{t-1}^{a',n'}, z_{t-1}^{c,o}) = Cov(r_{zz}^{n',l} z_{t-1}^{b,l} + r_{zy}^{n',l} y_{t-1}^{b,l}, z_{t-1}^{c,o}) = r_{zz}^{n',l} Cov(z_{t-1}^{b,l}, z_{t-1}^{c,o}) + r_{zy}^{n',l} Cov(y_{t-1}^{b,l}, z_{t-1}^{c,o})$$

$$Cov(z_{t-1}^{a',n'}, y_{t-1}^{c,o}) = Cov(r_{zz}^{n',l} z_{t-1}^{b,l} + r_{zy}^{n',l} y_{t-1}^{b,l}, y_{t-1}^{c,o}) = r_{zz}^{n',l} Cov(z_{t-1}^{b,l}, y_{t-1}^{c,o}) + r_{zy}^{n',l} Cov(y_{t-1}^{b,l}, y_{t-1}^{c,o})$$

$$Cov(y_{t-1}^{a',n'}, z_{t-1}^{c,o}) = Cov(r_{yz}^{n',l} z_{t-1}^{b,l} + r_{yy}^{n',l} y_{t-1}^{b,l}, z_{t-1}^{c,o}) = r_{yz}^{n',l} Cov(z_{t-1}^{b,l}, z_{t-1}^{c,o}) + r_{yy}^{n',l} Cov(y_{t-1}^{b,l}, z_{t-1}^{c,o})$$

$$Cov(y_{t-1}^{a',n'}, y_{t-1}^{c,o}) = Cov(r_{yz}^{n',l} z_{t-1}^{b,l} + r_{yy}^{n',l} y_{t-1}^{b,l}, y_{t-1}^{c,o}) = r_{yz}^{n',l} Cov(z_{t-1}^{b,l}, y_{t-1}^{c,o}) + r_{yy}^{n',l} Cov(y_{t-1}^{b,l}, y_{t-1}^{c,o})$$

where b and c are siblings in law.

We can recursively compute the covariances for siblings in law, spouses of the siblings in law and siblings of the siblings in law of any degree.

Cousins in law

We have to compute the covariances between " aa " and " cc ". Let $n^* = m, f$ be the gender of aa and $o^* = m, f$

the gender of the cc . We project cc on c (his/her father or mother) who has gender o

$$Cov(z_t^{aa,n^*}, z_t^{cc,o^*}) = Cov(z_t^{aa,n^*}, G_{zo}^{o^*} z_{t-1}^{c,o} + G_{yo}^{o^*} y_{t-1}^{c,o}) = G_{zo}^{o^*} Cov(z_t^{aa,n^*}, z_{t-1}^{c,o}) + G_{yo}^{o^*} Cov(z_t^{aa,n^*}, y_{t-1}^{c,o})$$

$$Cov(z_t^{aa,n^*}, y_t^{cc,o^*}) = Cov(z_t^{aa,n^*}, B_{zo}^{o^*} z_{t-1}^{c,o} + B_{yo}^{o^*} y_{t-1}^{c,o}) = B_{zo}^{o^*} Cov(z_t^{aa,n^*}, z_{t-1}^{c,o}) + B_{yo}^{o^*} Cov(z_t^{aa,n^*}, y_{t-1}^{c,o})$$

$$Cov(y_t^{aa,n^*}, z_t^{cc,o^*}) = Cov(y_t^{aa,n^*}, G_{zo}^{o^*} z_{t-1}^{c,o} + G_{yo}^{o^*} y_{t-1}^{c,o}) = G_{zo}^{o^*} Cov(y_t^{aa,n^*}, z_{t-1}^{c,o}) + G_{yo}^{o^*} Cov(y_t^{aa,n^*}, y_{t-1}^{c,o})$$

$$Cov(y_t^{aa,n^*}, y_t^{cc,o^*}) = Cov(y_t^{aa,n^*}, B_{zo}^{o^*} z_{t-1}^{c,o} + B_{yo}^{o^*} y_{t-1}^{c,o}) = B_{zo}^{o^*} Cov(y_t^{aa,n^*}, z_{t-1}^{c,o}) + B_{yo}^{o^*} Cov(y_t^{aa,n^*}, y_{t-1}^{c,o})$$

where c is the sibling in law of the uncle/aunt of aa . We can recursively compute the covariances for cousins in law of any degree.

J No Direct Effect and Assortative Mating Only in z

We next consider a latent factor model with no direct effect ($\beta = 0$) and assortative mating only in z . This model is less general than the previous one but it has the advantage that we can show how the parameters are identified.

We write the outcome y for an individual from generation t as

$$y_t^k = z_t^k + x_t^k + u_t^k \tag{J.1}$$

where the superscript $k = m$ stands for males and $k = f$ for females. We assume that the socioeconomic status of the child, z_t^k , depends on the father z_{t-1}^m as well as on the mother z_{t-1}^f

$$\begin{aligned} z_t^k &= \gamma^k z_{t-1}^k + e_t^k + v_t^k \\ \tilde{z}_{t-1}^k &= \alpha_z^k z_{t-1}^m + (1 - \alpha_z^k) z_{t-1}^f \end{aligned} \tag{J.2}$$

Regarding the shocks, we assume that x_t^k and e_t^k are shared by all siblings of the same gender, can be correlated across siblings of different gender and are uncorrelated to each other and with the other variables (in particular with z_{t-1}^k and y_{t-1}^l , $l = m, f$). Finally u_t^k and v_t^k are white-noise errors.

Notice that from (J.1)

$$Cov(y_t^k, z_t^k) = \sigma_{z^k}^2$$

J.1 Assortative mating process

We assume there is assortative mating only in z , i.e we assume that the coefficients of y_{t-1}^m in the linear projections of z_{t-1}^f and y_{t-1}^f on z_{t-1}^m and y_{t-1}^m are zero. This means that we can write z_{t-1}^f as

$$z_{t-1}^f = \frac{\sigma_{zf}}{\sigma_{zm}} \rho_{zmzf} z_{t-1}^m + w_{t-1}^m$$

where w_{t-1}^m is uncorrelated with z_{t-1}^m and y_{t-1}^m , and

$$y_{t-1}^f = \frac{\sigma_{zf}}{\sigma_{zm}} \rho_{zmzf} z_{t-1}^m + w_{t-1}^m + x_{t-1}^f + u_{t-1}^f$$

We have that

$$\sigma_{w^m}^2 = \sigma_{zf}^2 (1 - \rho_{zmzf}^2)$$

We use these matching functions to write years of schooling, y_t^k , and social status, z_t^k , as a function of the father social status z_{t-1}^m . We can write (J.2) as

$$\begin{aligned} z_t^k &= \gamma^k \left(\alpha_z^k z_{t-1}^m + (1 - \alpha_z^k) z_{t-1}^f \right) + e_t^k + v_t^k \\ &= \gamma^k \left(\alpha_z^k z_{t-1}^m + (1 - \alpha_z^k) \left(\frac{\sigma_{zf}}{\sigma_{zm}} \rho_{zmzf} z_{t-1}^m + w_{t-1}^m \right) \right) + e_t^k + v_t^k \\ &= G_{zm}^k z_{t-1}^m + g_m^k \omega_{t-1}^m + e_t^k + v_t^k \end{aligned}$$

where

$$\begin{aligned} G_{zm}^k &= \gamma^k (\alpha_z^k + (1 - \alpha_z^k) \frac{\sigma_{zf}}{\sigma_{zm}} \rho_{zmzf}) \\ g_m^k &= \gamma^k (1 - \alpha_z^k) \end{aligned}$$

and (J.1) as

$$y_t^k = G_{zm}^k z_{t-1}^m + g_m^k \omega_{t-1}^m + e_t^k + x_t^k + v_t^k + u_t^k$$

All these expressions will be used to compute correlations between relatives that are related through their fathers. However, when we consider relatives that are related through their mothers, we use the expressions for y_t^k and z_t^k as functions of mother

$$z_t^k = G_{zf}^k z_{t-1}^f + g_f^k \omega_{t-1}^f + e_t^k + v_t^k$$

where

$$\begin{aligned} G_{zf}^k &= \gamma^k (\alpha_z^k \frac{\sigma_{zm}}{\sigma_{zf}} \rho_{zmzf} + (1 - \alpha_z^k)) \\ g_f^k &= \gamma^k \alpha_z^k \end{aligned}$$

and (J.1) as

$$y_t^k = G_{zf}^k z_{t-1}^f + g_f^k \omega_{t-1}^f + e_t^k + x_t^k + v_t^k + u_t^k$$

We then have that the model has 13 parameters $\gamma^k, \alpha_z^k, \sigma_{z^k}^2, \sigma_{x^k}^2, \sigma_{e^k}^2, k = m, f, \sigma_{x^m x^f}, \sigma_{e^m e^f}, \rho_{zmzf}$.

J.2 Covariances

J.2.1 Main covariances

We first compute the main covariances (husband-wife, parent-child and siblings). Then, the covariances for other relatives are obtained recursively. We again use the notation in Figure 1 to denote individuals with different degrees of kinship.

Husband and wife $a - a'$

We have to compute the covariances between " a " and " a' ". Let $n' = m, f$ be the gender of a' and $n = f, m$ the gender of a

$$\begin{aligned} Cov(y_{t-1}^{a,n}, y_{t-1}^{a',n'}) &= Cov\left(\frac{\sigma_{z^n}}{\sigma_{z^{n'}}} \rho_{z^m z^f} z_{t-1}^{a',n'}, y_{t-1}^{a',n'}\right) \\ &= \frac{\sigma_{z^n}}{\sigma_{z^{n'}}} \rho_{z^m z^f} Cov(z_{t-1}^{a',n'}, y_{t-1}^{a',n'}) = \frac{\sigma_{z^n}}{\sigma_{z^{n'}}} \rho_{z^m z^f} \sigma_{z^{n'}}^2 = \sigma_{z^f} \sigma_{z^m} \rho_{z^m z^f} \end{aligned}$$

Parent-child $aa - a'$

We have to compute the covariances between " aa " and " a' ". Let $n^* = m, f$ be the gender of aa and $n' = m, f$ the gender of a' . We project aa on a' (his/her father or mother).

$$\begin{aligned} Cov(z_t^{aa,n^*}, z_{t-1}^{a',n'}) &= Cov(G_{z^{n'}}^{n^*} z_{t-1}^{a',n'}, z_{t-1}^{a',n'}) = G_{z^{n'}}^{n^*} \sigma_{z^{n'}}^2 \\ Cov(z_t^{aa,n^*}, y_{t-1}^{a',n'}) &= Cov(G_{z^{n'}}^{n^*} z_{t-1}^{a',n'}, y_{t-1}^{a',n'}) = G_{z^{n'}}^{n^*} \sigma_{z^{n'}}^2 \\ Cov(y_t^{aa,n^*}, z_{t-1}^{a',n'}) &= Cov(G_{z^{n'}}^{n^*} z_{t-1}^{a',n'}, z_{t-1}^{a',n'}) = G_{z^{n'}}^{n^*} \sigma_{z^{n'}}^2 \\ Cov(y_t^{aa,n^*}, y_{t-1}^{a',n'}) &= Cov(G_{z^{n'}}^{n^*} z_{t-1}^{a',n'}, y_{t-1}^{a',n'}) = G_{z^{n'}}^{n^*} \sigma_{z^{n'}}^2 \end{aligned}$$

Notice that in this case the four covariances take the same value.

Grandparent-child $aaa - a'$

We have to compute the covariances between " aaa " and " a' ". Let $n' = m, f$ be the gender of a' and $n^{**} = m, f$ the gender of the aaa . We project aaa on aa (his/her father or mother) who has gender n^*

$$\begin{aligned} Cov(z_{t+1}^{aaa,n^{**}}, z_{t-1}^{a',n'}) &= G_{z^{n^*}}^{n^{**}} Cov(z_t^{aa,n^*}, z_{t-1}^{a',n'}) \\ Cov(z_{t+1}^{aaa,n^{**}}, y_{t-1}^{a',n'}) &= G_{z^{n^*}}^{n^{**}} Cov(z_t^{aa,n^*}, z_{t-1}^{a',n'}) \\ Cov(y_{t+1}^{aaa,n^{**}}, z_{t-1}^{a',n'}) &= G_{z^{n^*}}^{n^{**}} Cov(z_t^{aa,n^*}, z_{t-1}^{a',n'}) \end{aligned}$$

$$Cov(y_{t+1}^{aaa,n^{**}}, y_{t-1}^{a',n'}) = G_{zn^*}^{n^{**}} Cov(z_t^{aa,n^*}, z_{t-1}^{a',n'})$$

Siblings $a' - b$

We have to compute the covariance between " a' " and " b ". Let $n' = m, f$ be the gender of a' and $l = m, f$ the gender of the b . We project a' and b on their father or mother $GP2$ who has gender k

$$\begin{aligned} Cov(z_{t-1}^{a',n'}, z_{t-1}^{b,l}) &= Cov(G_{zk}^{n'} z_{t-2}^{GP2,k} + g_k^{n'} \omega_{t-2}^{GP2,k} + e_{t-1}^{a',n'}, G_{zk}^l z_{t-2}^{GP2,k} + g_k^l \omega_{t-2}^{GP2,k} + e_{t-1}^{b,l}) \\ &= G_{zk}^{n'} G_{zk}^l \sigma_{z^k}^2 + g_k^{n'} g_k^l \sigma_{w^k}^2 + \sigma_{e^{n'} e^l} \end{aligned}$$

$$\begin{aligned} Cov(z_{t-1}^{a',n'}, y_{t-1}^{b,l}) &= Cov(G_{zk}^{n'} z_{t-2}^{GP2,k} + g_k^{n'} \omega_{t-2}^{GP2,k} + e_{t-1}^{a',n'}, G_{zk}^l z_{t-2}^{GP2,k} + g_k^l \omega_{t-2}^{GP2,k} + e_{t-1}^{b,l}) \\ &= G_{zk}^{n'} G_{zk}^l \sigma_{z^k}^2 + g_k^{n'} g_k^l \sigma_{w^k}^2 + \sigma_{e^{n'} e^l} \end{aligned}$$

$$\begin{aligned} Cov(y_t^{a',n'}, y_t^{b,l}) &= Cov(G_{zk}^{n'} z_{t-2}^{GP2,k} + g_k^{n'} \omega_{t-2}^{GP2,k} + e_{t-1}^{a',n'} + x_{t-1}^{a',n'}, G_{zk}^l z_{t-2}^{GP2,k} + g_k^l \omega_{t-2}^{GP2,k} + e_{t-1}^{b,l} + x_{t-1}^{b,l}) \\ &= G_{zk}^{n'} G_{zk}^l \sigma_{z^k}^2 + g_k^{n'} g_k^l \sigma_{w^k}^2 + \sigma_{e^{n'} e^l} + \sigma_{x^{n'} x^l} \end{aligned}$$

J.2.2 Other covariances

Consanguine relatives ("blood")

Vertical covariances

Uncle/aunt (siblings of the parents) $aa - b$

We have to compute the covariances between " aa " and " b ". Let $n^* = m, f$ be the gender of aa and $l = m, f$ the gender of the b . We project aa on a' (his/her father or mother) who has gender n'

$$Cov(z_t^{aa,n^*}, z_{t-1}^{b,l}) = Cov(G_{zn'}^{n^*} z_{t-1}^{a',n'}, z_{t-1}^{b,l}) = G_{zn'}^{n^*} Cov(z_{t-1}^{a',n'}, z_{t-1}^{b,l})$$

$$Cov(z_t^{aa,n^*}, y_{t-1}^{b,l}) = Cov(G_{zn'}^{n^*} z_{t-1}^{a',n'}, y_{t-1}^{b,l}) = G_{zn'}^{n^*} Cov(z_{t-1}^{a',n'}, y_{t-1}^{b,l})$$

$$Cov(y_t^{aa,n^*}, z_{t-1}^{b,l}) = Cov(G_{zn'}^{n^*} z_{t-1}^{a',n'}, z_{t-1}^{b,l}) = G_{zn'}^{n^*} Cov(z_{t-1}^{a',n'}, z_{t-1}^{b,l})$$

$$Cov(y_t^{aa,n^*}, y_{t-1}^{b,l}) = Cov(G_{zn'}^{n^*} z_{t-1}^{a',n'}, y_{t-1}^{b,l}) = G_{zn'}^{n^*} Cov(z_{t-1}^{a',n'}, y_{t-1}^{b,l})$$

where a' and b are siblings.

Horizontal covariances

Cousins $aa - bb$

We have to compute the covariances between " aa " and " bb ". Let $n^* = m, f$ be the gender of aa and $l^* = m, f$ the gender of the bb . We project bb on b (his/her father or mother) who has gender l

$$Cov(z_t^{aa,n^*}, z_t^{bb,l^*}) = Cov(z_t^{aa,n^*}, G_{zl}^{l^*} z_{t-1}^{b,l}) = G_{zl}^{l^*} Cov(z_t^{aa,n^*}, z_{t-1}^{b,l})$$

$$Cov(z_t^{aa,n^*}, y_t^{bb,l^*}) = Cov(z_t^{aa,n^*}, G_{zl}^{l^*} z_{t-1}^{b,l}) = G_{zl}^{l^*} Cov(z_t^{aa,n^*}, z_{t-1}^{b,l})$$

$$Cov(y_t^{aa,n^*}, z_t^{bb,l^*}) = Cov(y_t^{aa,n^*}, G_{z_l}^{l^*} z_{t-1}^{b,l}) = G_{z_l}^{l^*} Cov(y_t^{aa,n^*}, z_{t-1}^{b,l})$$

$$Cov(y_t^{aa,n^*}, y_t^{bb,l^*}) = Cov(y_t^{aa,n^*}, G_{z_l}^{l^*} z_{t-1}^{b,l}) = G_{z_l}^{l^*} Cov(y_t^{aa,n^*}, z_{t-1}^{b,l})$$

where b is the uncle/aunt of aa .

Affinity relatives ("in-law")

Vertical covariances

Spouse of the uncle/aunt (spouses of the siblings of the parents) $aa - b'$

We have to compute the covariances between " aa " and " b' ". Let $n^* = m, f$ be the gender of aa and $l' = m, f$ the gender of the b' . We project b' on his/her spouse b with gender l

$$Cov(z_t^{aa,n^*}, z_{t-1}^{b',l'}) = Cov(z_t^{aa,n^*}, \frac{\sigma_{z_l'}}{\sigma_{z_l}} \rho_{z^m z^f} z_{t-1}^{b,l}) = \frac{\sigma_{z_l'}}{\sigma_{z_l}} \rho_{z^m z^f} Cov(z_t^{aa,n^*}, z_{t-1}^{b,l})$$

$$Cov(z_t^{aa,n^*}, y_{t-1}^{b',l'}) = Cov(z_t^{aa,n^*}, \frac{\sigma_{z_l'}}{\sigma_{z_l}} \rho_{z^m z^f} z_{t-1}^{b,l}) = \frac{\sigma_{z_l'}}{\sigma_{z_l}} \rho_{z^m z^f} Cov(z_t^{aa,n^*}, z_{t-1}^{b,l})$$

$$Cov(y_t^{aa,n^*}, z_{t-1}^{b',l'}) = Cov(y_t^{aa,n^*}, \frac{\sigma_{z_l'}}{\sigma_{z_l}} \rho_{z^m z^f} z_{t-1}^{b,l}) = \frac{\sigma_{z_l'}}{\sigma_{z_l}} \rho_{z^m z^f} Cov(y_t^{aa,n^*}, z_{t-1}^{b,l})$$

$$Cov(y_t^{aa,n^*}, y_{t-1}^{b',l'}) = Cov(y_t^{aa,n^*}, \frac{\sigma_{z_l'}}{\sigma_{z_l}} \rho_{z^m z^f} z_{t-1}^{b,l}) = \frac{\sigma_{z_l'}}{\sigma_{z_l}} \rho_{z^m z^f} Cov(y_t^{aa,n^*}, z_{t-1}^{b,l})$$

where b is uncle/aunt of aa .

Horizontal covariances

Siblings in law $a - b$

We have to compute the covariances between a and b . Let $n = m, f$ be the gender of a and $l = m, f$ the gender of the b . We project a on his/her spouse a' with gender n'

$$Cov(z_{t-1}^{a,n}, z_{t-1}^{b,l}) = Cov\left(\frac{\sigma_{z_n}}{\sigma_{z_{n'}}} \rho_{z^m z^f} z_{t-1}^{a',n'}, z_{t-1}^{b,l}\right) = \frac{\sigma_{z_n}}{\sigma_{z_{n'}}} \rho_{z^m z^f} Cov(z_{t-1}^{a',n'}, z_{t-1}^{b,l})$$

$$Cov(z_{t-1}^{a,n}, y_{t-1}^{b,l}) = Cov\left(\frac{\sigma_{z_n}}{\sigma_{z_{n'}}} \rho_{z^m z^f} z_{t-1}^{a',n'}, y_{t-1}^{b,l}\right) = \frac{\sigma_{z_n}}{\sigma_{z_{n'}}} \rho_{z^m z^f} Cov(z_{t-1}^{a',n'}, y_{t-1}^{b,l})$$

$$Cov(y_{t-1}^{a,n}, z_{t-1}^{b,l}) = Cov\left(\frac{\sigma_{z_n}}{\sigma_{z_{n'}}} \rho_{z^m z^f} z_{t-1}^{a',n'}, z_{t-1}^{b,l}\right) = \frac{\sigma_{z_n}}{\sigma_{z_{n'}}} \rho_{z^m z^f} Cov(z_{t-1}^{a',n'}, z_{t-1}^{b,l})$$

$$Cov(y_{t-1}^{a,n}, y_{t-1}^{b,l}) = Cov\left(\frac{\sigma_{z_n}}{\sigma_{z_{n'}}} \rho_{z^m z^f} z_{t-1}^{a',n'}, y_{t-1}^{b,l}\right) = \frac{\sigma_{z_n}}{\sigma_{z_{n'}}} \rho_{z^m z^f} Cov(z_{t-1}^{a',n'}, y_{t-1}^{b,l})$$

where a' and b are siblings.

We now compute the covariances between " a' " and " b' ". Let $n' = m, f$ be the gender of " a' " and $l' = m, f$ the gender of the b' . We project b' on his/her spouse b with gender l

$$Cov(z_{t-1}^{a',n'}, z_{t-1}^{b',l'}) = Cov\left(z_{t-1}^{a',n'}, \frac{\sigma_{z_l'}}{\sigma_{z_l}} \rho_{z^m z^f} z_{t-1}^{b,l}\right) = \frac{\sigma_{z_l'}}{\sigma_{z_l}} \rho_{z^m z^f} Cov(z_{t-1}^{a',n'}, z_{t-1}^{b,l})$$

$$Cov(z_{t-1}^{a',n'}, y_{t-1}^{b',l'}) = Cov\left(z_{t-1}^{a',n'}, \frac{\sigma_{z^{l'}}}{\sigma_{z^l}} \rho_{z^m z^f} z_{t-1}^{b,l}\right) = \frac{\sigma_{z^{l'}}}{\sigma_{z^l}} \rho_{z^m z^f} Cov(z_{t-1}^{a',n'}, z_{t-1}^{b,l})$$

$$Cov(y_{t-1}^{a',n'}, z_{t-1}^{b',l'}) = Cov\left(y_{t-1}^{a',n'}, \frac{\sigma_{z^{l'}}}{\sigma_{z^l}} \rho_{z^m z^f} z_{t-1}^{b,l}\right) = \frac{\sigma_{z^{l'}}}{\sigma_{z^l}} \rho_{z^m z^f} Cov(y_{t-1}^{a',n'}, z_{t-1}^{b,l})$$

$$Cov(y_{t-1}^{a',n'}, y_{t-1}^{b',l'}) = Cov\left(y_{t-1}^{a',n'}, \frac{\sigma_{z^{l'}}}{\sigma_{z^l}} \rho_{z^m z^f} z_{t-1}^{b,l}\right) = \frac{\sigma_{z^{l'}}}{\sigma_{z^l}} \rho_{z^m z^f} Cov(y_{t-1}^{a',n'}, z_{t-1}^{b,l})$$

where "a'" and "b'" are siblings. Notice that since "a'" is the spouse of "a", $n = f$ when $n' = m$ and viceversa.

Spouse of the siblings in law $a - b'$

We have to compute the covariances between "a'" and "b'". Let $n = m, f$ be the gender of a and $l' = m, f$ the gender of the b' . We project b' on his/her spouse b with gender l

$$Cov(z_{t-1}^{a,n}, z_{t-1}^{b',l'}) = Cov\left(z_{t-1}^{a,n}, \frac{\sigma_{z^{l'}}}{\sigma_{z^l}} \rho_{z^m z^f} z_{t-1}^{b,l}\right) = \frac{\sigma_{z^{l'}}}{\sigma_{z^l}} \rho_{z^m z^f} Cov(z_{t-1}^{a,n}, z_{t-1}^{b,l})$$

$$Cov(z_{t-1}^{a,n}, y_{t-1}^{b',l'}) = Cov\left(z_{t-1}^{a,n}, \frac{\sigma_{z^{l'}}}{\sigma_{z^l}} \rho_{z^m z^f} z_{t-1}^{b,l}\right) = \frac{\sigma_{z^{l'}}}{\sigma_{z^l}} \rho_{z^m z^f} Cov(z_{t-1}^{a,n}, z_{t-1}^{b,l})$$

$$Cov(y_{t-1}^{a,n}, z_{t-1}^{b',l'}) = Cov\left(y_{t-1}^{a,n}, \frac{\sigma_{z^{l'}}}{\sigma_{z^l}} \rho_{z^m z^f} z_{t-1}^{b,l}\right) = \frac{\sigma_{z^{l'}}}{\sigma_{z^l}} \rho_{z^m z^f} Cov(y_{t-1}^{a,n}, z_{t-1}^{b,l})$$

$$Cov(y_{t-1}^{a,n}, y_{t-1}^{b',l'}) = Cov\left(y_{t-1}^{a,n}, \frac{\sigma_{z^{l'}}}{\sigma_{z^l}} \rho_{z^m z^f} z_{t-1}^{b,l}\right) = \frac{\sigma_{z^{l'}}}{\sigma_{z^l}} \rho_{z^m z^f} Cov(y_{t-1}^{a,n}, z_{t-1}^{b,l})$$

where a and b are siblings in law.

J.3 Correlations

We now compute the correlations in y for different degrees of kinship using the formulas for the covariances we derive above. We denote the correlations by $\rho_{i,n-j,l}$, where i and j denote the corresponding relatives, and n and l are the genders of i and j respectively

Husband and wife $a - a'$

$$\rho_{a-a'} = \frac{\sigma_{z^f} \sigma_{z^m}}{\sigma_{y^f} \sigma_{y^m}} \rho_{z^f z^m}$$

Parent-child $aa - a'$

$$\rho_{aa,n^*-a',n'} = G_{zn'}^{n^*} \frac{\sigma_{z^{n^*}} \sigma_{z^{n'}}}{\sigma_{y^{n^*}} \sigma_{y^{n'}}$$

Grandparent-child $aaa - a'$

$$\rho_{aaa,n^{**}-a',n'} = G_{zn'}^{n^{**}} \rho_{aa,n^*-a',n'}$$

Siblings $a' - b$

$$\rho_{a',n'-b,l} = G_{zk}^{m'} G_{zk}^l \frac{\sigma_{z^k} \sigma_{z^k}}{\sigma_{y^{n'}} \sigma_{y^l}} + g_k^{n'} g_k^l \frac{\sigma_{w^k} \sigma_{w^k}}{\sigma_{y^{n'}} \sigma_{y^l}} + \frac{\sigma_{\epsilon^{n'} \epsilon^l}}{\sigma_{y^{n'}} \sigma_{y^l}} + \frac{\sigma_{x^{n'} x^l}}{\sigma_{y^{n'}} \sigma_{y^l}}$$

Uncle/aunt (siblings of the parents) $aa - b$

$$\rho_{aa,n^*-b,l} = G_{zn'}^{m^*} \frac{\sigma_{y^{n'}}}{\sigma_{y^{n^*}}} \left(G_{zk}^{n'} G_{zk}^l \frac{\sigma_{z^k}}{\sigma_{y^{n'}}} \frac{\sigma_{z^k}}{\sigma_{y^l}} + g_k^{n'} g_k^l \frac{\sigma_{w^k}}{\sigma_{y^{n'}}} \frac{\sigma_{w^k}}{\sigma_{y^l}} + \frac{\sigma_{e^{n'} e^l}}{\sigma_{y^{n'} \sigma_{y^l}}} \right) \quad (\text{J.3})$$

Cousins $aa - bb$

$$\rho_{aa,n^*-b,l^*} = G_{zl}^{l^*} \frac{\sigma_{y^l}}{\sigma_{y^{l^*}}} \rho_{aa,n^*-b,l}$$

Spouse of the uncle/aunt (spouses of the siblings of the parents) $aa - b'$

$$\rho_{aa,n^*-b',l'} = \frac{\sigma_{z^{l'}}}{\sigma_{z^l}} \rho_{zmzf} \frac{\sigma_{y^l}}{\sigma_{y^{l'}}} \rho_{aa,n^*-b,l} \quad (\text{J.4})$$

Siblings in law $a - b$ or $a' - b'$

$$\begin{aligned} \rho_{a,n-b,l} &= \frac{\sigma_{z^n}}{\sigma_{z^{n'}}} \rho_{zmzf} \frac{\sigma_{y^{n'}}}{\sigma_{y^n}} \left(G_{zk}^{n'} G_{zk}^l \frac{\sigma_{z^k}}{\sigma_{y^{n'}}} \frac{\sigma_{z^k}}{\sigma_{y^l}} + g_k^{n'} g_k^l \frac{\sigma_{w^k}}{\sigma_{y^{n'}}} \frac{\sigma_{w^k}}{\sigma_{y^l}} + \frac{\sigma_{e^{n'} e^l}}{\sigma_{y^{n'} \sigma_{y^l}}} \right) \\ \rho_{a',n'-b',l'} &= \frac{\sigma_{z^{l'}}}{\sigma_{z^l}} \rho_{zmzf} \frac{\sigma_{y^l}}{\sigma_{y^{l'}}} \left(G_{zk}^{n'} G_{zk}^l \frac{\sigma_{z^k}}{\sigma_{y^{n'}}} \frac{\sigma_{z^k}}{\sigma_{y^l}} + g_k^{n'} g_k^l \frac{\sigma_{w^k}}{\sigma_{y^{n'}}} \frac{\sigma_{w^k}}{\sigma_{y^l}} + \frac{\sigma_{e^{n'} e^l}}{\sigma_{y^{n'} \sigma_{y^l}}} \right) \end{aligned} \quad (\text{J.5})$$

Spouse of the siblings in law $a - b'$

$$\rho_{a,n-b',l'} = \frac{\sigma_{z^{l'}}}{\sigma_{z^l}} \rho_{zmzf} \frac{\sigma_{y^l}}{\sigma_{y^{l'}}} \rho_{a,n-b,l}$$

J.4 Identification

Our baseline model cannot be solved analytically, that is we cannot write the parameters of the model as functions of the correlations between different types of relatives. However, to provide some intuition about how the parameters are identified, we show identification in this restricted model with no direct effect ($\beta = 0$) and assortative mating occurring only in the latent factor z (i.e. we assume that the coefficients of y_{t-1}^m in the linear projections of z_{t-1}^f and y_{t-1}^f on z_{t-1}^m and y_{t-1}^m are zero).

Assortative process. First, note that the ratio of the spouse of the sibling in law to the sibling in law (or the ratio of the uncle in law to the uncle) identifies

$$\frac{\rho_{a,n-b',l'}}{\rho_{a,n-b,l}} = \frac{\rho_{aa,n^*-b',l'}}{\rho_{aa,n^*-b,l}} = \rho_{zmzf} \frac{\sigma_{z^{l'}}/\sigma_{y^{l'}}}{\sigma_{z^l}/\sigma_{y^l}} \quad (\text{J.6})$$

Moreover, σ_{y^m} and σ_{y^f} are observable. Notice that the ratio on the left-hand side corresponds to an instrumental variable regression in which the outcome of the spouse b in the spousal regression $b' - b$ is instrumented with the outcome of the *spouse's sibling in law* a (or the spouse's nephew or niece aa). This IV regression effectively swaps the correlations in equation (J.6) for covariances and therefore identifies $\rho_{zmzf} \frac{\sigma_{z^{l'}}}{\sigma_{z^l}}$. Then,

if there are no gender asymmetries in the variances, that is, if $\sigma_{yf} = \sigma_{ym}$ and $\sigma_{zf} = \sigma_{zm}$, the IV regression estimates the assortative parameter $\rho_{z^m z^f}$.

The IV approach therefore needs to be based on sufficiently distant in-laws. In particular, notice that the ratio of sibling in law to sibling does not identify the assortative parameter, i.e. the spouse's *sibling* a' is not a valid instrument for the spouse b in the spousal regression $b - b'$. The reason is that the sibling component x_t is shared by siblings but not by spouses or other in-laws. For the identification of the assortative process, we therefore need to “break” the sibling link by comparing kinship moments that are sufficiently distant.

In the general model with potential gender asymmetries, we can use the product of the ratios of the correlations with the brother in law and his wife ($l = m$ and $l' = f$) and with the sister in law and his husband ($l = f$ and $l' = m$) to identify the assortative mating parameter, $\rho_{z^m z^f}$,

$$\frac{\rho_{a,n-b',f} \rho_{a,n-b',m}}{\rho_{a,n-b,m} \rho_{a,n-b,f}} = \rho_{z^m z^f}^2 \quad (\text{J.7})$$

The assortative mating parameter can also be identified from the product of the ratios of the correlations with uncle and his wife ($l = m$ and $l' = f$) and aunt and his husband ($l = f$ and $l' = m$). In contrast, standardizing the outcome variable by gender would not fully abstract from gender asymmetries. As is clear from equation (J.6), the estimates would be still biased by the gender difference in the variance share of the latent variable, $\frac{\sigma_{z^{l'}}/\sigma_{y^{l'}}}{\sigma_{z^l}/\sigma_{y^l}}$.

Intergenerational process (considering extended kins in the parent generation). Next, we can identify the reduced-form intergenerational transmission parameters, $G_{zn'}^{n^*}$, $n', n^* = m, f$, from the ratio of the spouse of the uncle to the sibling in law,

$$\frac{\rho_{aa,n^*-b',l'}}{\rho_{a',n'-b',l'}} = G_{zn'}^{n^*} \frac{\sigma_{y^{n'}}}{\sigma_{y^{n^*}}}$$

Notice that this ratio corresponds to the instrumental variable regression in which the outcome of the parent a' in the parent-child regression $aa - a'$ is instrumented with the outcome of the parent's sibling in law b' (or the parent's own parent, see below).

As for the assortative process, researchers need to consider sufficiently distant relatives in order to abstract from sibling links and to isolate the intergenerational process. In particular, notice that we cannot use the ratio of uncle to siblings to identify the intergenerational parameters because x is shared by siblings but is not transmitted to their descendants. Accordingly, the corresponding IV approach in which the outcome of the parent a' is instrumented with the parent's sibling b (i.e., the child's aunt or uncle) is biased.

Intergenerational process (considering grandparents). Alternatively, one can identify the strength of the intergenerational process from multigenerational data across three generations (as in [Lindahl et al., 2015](#), or [Braun and Stuhler, 2018](#)). In our simplified model, the ratio between the grandparent-child and the parent-child correlations identifies

$$\frac{\rho_{aaa,n^{**}-a',n'}}{\rho_{aa,n^*-a',n'}} = G_{zn'}^{n^{**}}$$

The reduced-form intergenerational transmission parameter $G_{zn'}^{n^{**}}$ depends in turn on the strength of the

intergenerational transmission γ^k , the assortative parameter $\rho_{z^m z^f}$, and gender-specific weights. The corresponding IV approach of using the outcome of the grandparent a' as an instrument for the parent aa in the parent-child regression $aaa - aa$ swaps these correlations with covariances, and therefore identifies $G_{zn'}^{m**} \frac{\sigma_{y^{n**}}}{\sigma_{y^{n*}}}$. Once the $G_{zn'}^{n^*}$, $n', n^* = m, f$ are identified, we can identify the share of the variances of y^f and y^m explained by the latent factor, $\frac{\sigma_{z^{n'}}^2}{\sigma_{y^{n'}}^2}$, $n' = m, f$ from the parent child correlations

$$\frac{\sigma_{z^{n'}}^2}{\sigma_{y^{n'}}^2} = \frac{\rho_{aa, n^* - a', n'}}{G_{zn'}^{n^*}}$$

Next, using the definition of $G_{zn'}^{n^*}$ for different gender combinations, we have that

$$\begin{aligned} \gamma^k \alpha_z^k &= \frac{G_{zm}^k - G_{zf}^k \frac{\sigma_{zf}}{\sigma_{zm}} \rho_{zm z^f}}{1 - \rho_{zm z^f}^2} \\ \gamma^k &= G_{zf}^k - \gamma^k \alpha_z^k \left(\frac{\sigma_{zm}}{\sigma_{zf}} \rho_{zm z^f} - 1 \right) \end{aligned}$$

and we can identify γ^k and α_z^k , $k = m, f$. If there are no gender asymmetries, that is if $\gamma^f = \gamma^m = \gamma$, $\alpha^f = \alpha^m = \frac{1}{2}$, $\sigma_{yf} = \sigma_{ym}$ and $\sigma_{zf} = \sigma_{zm}$, the reduced form intergenerational transmission parameters are all equal to $\frac{\gamma}{2}(1 + \rho_{zm z^f})$ and we can identify the pure intergenerational transmission parameter, γ , by

$$\gamma = \frac{2 \frac{\rho_{aa-b'}}{\rho_{a'-b'}}}{1 + \frac{\rho_{a-b'}}{\rho_{a-b}}} = \frac{2\rho_{aa-b'}}{\rho_{a-b} + \rho_{a-b'}}$$

Next, using the eight uncles correlations for different gender combinations ($n^*, l, k = m, f$)

$$\rho_{aa, n^* - b, l} = G_{zn'}^{m^*} \frac{\sigma_{y^{n'}}}{\sigma_{y^{n^*}}} \left(G_{zk}^{n'} G_{zk}^l \frac{\sigma_{zk}}{\sigma_{y^{n'}}} \frac{\sigma_{zk}}{\sigma_{y^l}} + g_k^{n'} g_k^l \frac{\sigma_{wk}}{\sigma_{y^{n'}}} \frac{\sigma_{wk}}{\sigma_{y^l}} + \frac{\sigma_{e^{n'} e^l}}{\sigma_{y^{n'} \sigma_{y^l}}} \right)$$

we can identify $\sigma_{e^{n'}}^2$, $n' = m, f$ and $\sigma_{e^m e^f}$. Finally from the three siblings correlations for different gender combinations

$$\rho_{a', n' - b, l} = G_{zk}^{m'} G_{zk}^l \frac{\sigma_{zk}}{\sigma_{y^{n'}}} \frac{\sigma_{zk}}{\sigma_{y^l}} + g_k^{n'} g_k^l \frac{\sigma_{wk}}{\sigma_{y^{n'}}} \frac{\sigma_{wk}}{\sigma_{y^l}} + \frac{\sigma_{e^{n'} e^l}}{\sigma_{y^{n'} \sigma_{y^l}}} + \frac{\sigma_{x^{n'} x^l}}{\sigma_{y^{n'} \sigma_{y^l}}}$$

we can identify $\sigma_{x^{n'}}^2$, $n' = m, f$ and $\sigma_{x^m x^f}$.

Notice that, under classical measurement errors, all correlations would decrease in the same proportion and therefore, since in this model the parameters are identified as ratios of correlations, classical measurement errors will not bias our estimates. In the general model with β^k different from zero, classical measurement errors can bias the results. However, since our estimated β^k are close to zero, we expect that measurement errors do not affect much the estimates. To confirm this intuition, we have calibrated the parameters of the general model when we increase all the correlations by 10%. The estimated parameters are very close to our benchmark estimates (the results are available upon request).

K The Reduced Form Model

We now study when our general model can be written as a reduced form model where the transmission takes place only through the male line. We consider the following reduced form model where the outcome y for an individual from generation t only depends on his father, and is given by

$$y_t = \beta y_{t-1}^m + z_t + x_t + u_t \quad (\text{K.1})$$

and the socioeconomic status of the child, z_t , only depends on the father z_{t-1}^m

$$z_t = \gamma z_{t-1}^m + e_t + v_t \quad (\text{K.2})$$

Substituting (K.2) in (K.1)

$$y_t = \beta y_{t-1}^m + \gamma z_{t-1}^m + e_t + v_t + x_t + u_t \quad (\text{K.3})$$

Regarding the shocks, as in the general model, we assume that x_t and e_t are shared by all siblings and are uncorrelated to each other and with the other variables (in particular with z_{t-1}^m and y_{t-1}^m). Finally u_t and v_t are white-noise errors.

We can now compare (K.2) and (K.3) with the expression for z_t^k and y_t^k as a function of the father obtained for the general model

$$z_t^k = G_{zm}^k z_{t-1}^m + G_{ym}^k y_{t-1}^m + g_m^k \omega_{t-1}^m + e_t^k + v_t^k \quad (\text{K.4})$$

$$y_t^k = B_{ym}^k y_{t-1}^m + B_{zm}^k z_{t-1}^m + b_m^k \varepsilon_{t-1}^m + g_m^k \omega_{t-1}^m + e_t^k + v_t^k + x_t^k + u_t^k \quad (\text{K.5})$$

where

$$\begin{aligned} G_{zm}^k &= \gamma^k (\alpha_z^k + (1 - \alpha_z^k) r_{zz}^m) \\ G_{ym}^k &= \gamma^k (1 - \alpha_z^k) r_{zy}^m \\ g_m^k &= \gamma^k (1 - \alpha_z^k) \end{aligned}$$

$$\begin{aligned} B_{ym}^k &= \beta^k (\alpha_y^k + (1 - \alpha_y^k) r_{yy}^m) + G_{ym}^k \\ B_{zm}^k &= \beta^k (1 - \alpha_y^k) r_{yz}^m + G_{zm}^k \\ b_m^k &= \beta^k (1 - \alpha_y^k) \end{aligned}$$

It is then easy to see that there are two key differences between the two models:

1. The errors in (K.2) are assumed to be orthogonal to y_{t-1}^m and z_{t-1}^m , whereas in (K.4), z_t^k depends on y_{t-1}^m and therefore, unless $G_{ym}^k = 0$, if we project y_t^m on z_{t-1}^m , the new error will be correlated to y_{t-1}^m .
2. In the reduced form model, z_{t-1}^m has the same coefficient in (K.2) and (K.1), whereas in the general

model, the coefficient of z_{t-1}^m is different in (K.4) and (K.5).

Then, we have that the general model can be written as a reduced form model if and only if the following two conditions are satisfied

1. $G_{ym}^k = 0 \iff \gamma^k = 0$, or $\alpha_z^k = 1$ or $r_{zy}^m = 0$
2. $B_{zm}^k = G_{zm}^k \iff \beta^k = 0$, or $\alpha_y^k = 1$ or $r_{yz}^m = 0$

We then have that the general model can be written as a reduced form model

1. In the trivial case when just the father matters ($\alpha_z^k = \alpha_y^k = 1$, or $\alpha_z^k = 1$ and $\beta^k = 0$, or $\alpha_y^k = 1$ and $\gamma^k = 0$).
2. When $\beta^k = 0$ and y_{t-1}^m does not influence z_{t-1}^f once the effect of z_{t-1}^m has been netted out ($r_{zy}^m = 0$).
3. When $\gamma^k = 0$ and z_{t-1}^m does not influence y_{t-1}^f once the effect of y_{t-1}^m has been netted out ($r_{yz}^m = 0$).
4. When y_{t-1}^m does not influence z_{t-1}^f once the effect of z_{t-1}^m has been netted out ($r_{zy}^m = 0$), and z_{t-1}^m does not influence y_{t-1}^f once the effect of y_{t-1}^m has been netted out ($r_{yz}^m = 0$).

Notice that Case 2 corresponds to a latent factor model with assortative mating only in z (this is the model we consider in Section J) and Case 3 to a direct effect model with assortative mating only in y . In our baseline specification, our calibrated parameters are close to satisfy the restrictions of Case 2, however, it is worth mentioning than using only male moments we cannot identify all the parameters. From Subsection J.4, we know we can identify G_{zm}^m from the ratio of the correlation with the spouse of the aunt to the correlation with the brother in law

$$G_{zm}^m = \frac{\rho_{aa,m-b',m}}{\rho_{a',m-b',m}}$$

and using G_{zm}^m and the father son correlation, we can identify $\frac{\sigma_{zm}^2}{\sigma_{ym'}^2}$ from

$$\frac{\sigma_{zm}^2}{\sigma_{ym}^2} = \frac{\rho_{aa,m-a',m}}{G_{zm}^m}$$

However, as it is shown in Subsection J.4, to identify ρ_{zmzf} we need the ratio of the correlation with the spouse of the aunt to the correlation with the aunt, and the ratio of the correlation with the spouse of the uncle to the correlation with the uncle, and therefore we need moments involving females. Moreover, to identify γ^m and α_z^m we need to use G_{zn}^{m*} for different gender combinations, that is we again need to use moments involving females. Finally to identify σ_{em}^2 , we need the correlations between nephew and uncle (brother of the father and brother of the mother), G_{zm}^m and G_{zf}^m and therefore we need female moments to identify G_{zf}^m . Since we cannot identify σ_{em}^2 using only male moments, we cannot identify σ_{xm}^2 from the brothers correlation.

L The Genetic Model

The genetic model is nested in our general model by imposing the following restrictions:

- There is no a direct effect of parents outcome on children outcome ($\beta^k = 0$, $k = f, m$), and hence

$$y_t^k = z_t^k + x_t^k + u_t^k$$

Then $Cov(y_t^k, z_t^k) = \sigma_z^2$ and $\rho_{z^k y^k} = \sigma_z / \sigma_{y^k}$.

- The latent factor is genetic and therefore it is transmitted from parents to children as

$$z_t^k = \frac{z_{t-1}^m + z_{t-1}^f}{2} + v_t^k$$

where v_t^k is uncorrelated across relatives and to z_{t-1}^m and z_{t-1}^f ($\gamma^k = 1$ and $\sigma_{e_k}^2 = 0$, $k = f, m$).

- The share of the variance explained by the latent factor is equal across genders ($\sigma_{z^k}^2 = \sigma_z^2$, $k = f, m$)
- There is assortative mating only in the observed outcome y ($\rho_{z^m y^f}$, $\rho_{y^m z^f}$ and $\rho_{z^m z^f}$ are functions of $\rho_{y^m y^f}$ and some of the other parameters of the model).

The genetic model has only 5 parameters: σ_z^2 , $\sigma_{x^m}^2$, $\sigma_{x^f}^2$, $\sigma_{x^m x^f}$, $\rho_{y^m y^f}$.

L.1 Assortative mating process

Under the assumption of assortative mating only in y , the coefficients of the linear projections z_{t-1}^f and y_{t-1}^f on z_{t-1}^m and y_{t-1}^m are

$$r_{zz}^m = \frac{1}{(1 - \rho_{z^m y^m}^2)} \frac{\sigma_{z^f}}{\sigma_{z^m}} (\rho_{z^m z^f} - \rho_{z^m y^m} \rho_{y^m z^f}) = 0 \Rightarrow \rho_{z^m z^f} = \rho_{z^m y^m} \rho_{y^m z^f} = \frac{\sigma_z}{\sigma_{y^m}} \rho_{y^m z^f}$$

$$r_{zy}^m = \frac{\sigma_z}{\sigma_{y^m}} \rho_{y^m z^f}$$

$$r_{yz}^m = \frac{1}{(1 - \rho_{z^m y^m}^2)} \frac{\sigma_{y^f}}{\sigma_{z^m}} (\rho_{z^m y^f} - \rho_{z^m y^m} \rho_{y^m y^f}) = 0 \Rightarrow \rho_{z^m y^f} = \rho_{z^m y^m} \rho_{y^m y^f} = \frac{\sigma_z}{\sigma_{y^m}} \rho_{y^m y^f}$$

$$r_{yy}^m = \frac{\sigma_{y^f}}{\sigma_{y^m}} \rho_{y^m y^f}$$

and the coefficients of the linear projections of z_{t-1}^m and y_{t-1}^m on z_{t-1}^f and y_{t-1}^f are:

$$r_{zz}^f = \frac{1}{(1 - \rho_{z^f y^f}^2)} \frac{\sigma_{z^m}}{\sigma_{z^f}} (\rho_{z^m z^f} - \rho_{z^f y^f} \rho_{z^m y^f}) = 0 \Rightarrow \rho_{z^m z^f} = \rho_{z^f y^f} \rho_{z^m y^f} = \frac{\sigma_z}{\sigma_{y^f}} \rho_{z^m y^f} = \frac{\sigma_z^2}{\sigma_{y^f} \sigma_{y^m}} \rho_{y^m y^f}$$

$$r_{zy}^f = \frac{\sigma_z}{\sigma_{y^f}} \rho_{z^m y^f}$$

$$r_{yz}^f = \frac{1}{(1 - \rho_{z^f y^f}^2)} \frac{\sigma_{y^m}}{\sigma_{z^f}} (\rho_{y^m z^f} - \rho_{z^f y^f} \rho_{y^m y^f}) = 0 \Rightarrow \rho_{y^m z^f} = \rho_{z^f y^f} \rho_{y^m y^f} = \frac{\sigma_z}{\sigma_{y^f}} \rho_{y^m y^f}$$

$$r_{yy}^f = \frac{\sigma_{y^m}}{\sigma_{y^f}} \rho_{y^m y^f}$$

Then, we have that

$$r_{zy}^m = r_{zy}^f = \frac{\sigma_z}{\sigma_{y^m}} \rho_{y^m z^f} = \frac{\sigma_z^2}{\sigma_{y^f} \sigma_{y^m}} \rho_{y^m y^f}$$

$$r_{yy}^m = \frac{\sigma_{y^f}}{\sigma_{y^m}} \rho_{y^m y^f}$$

$$r_{zy}^f = \frac{\sigma_z}{\sigma_{y^f}} \rho_{z^m y^f}$$

and

$$\sigma_{w^m}^2 = \sigma_z^2 - \left(\frac{\sigma_z^2}{\sigma_{y^m} \sigma_{y^f}} \rho_{y^m y^f} \right)^2 \sigma_{y^m}^2 = \sigma_z^2 \left(1 - \frac{\sigma_z^2}{\sigma_{y^f}^2} \rho_{y^m y^f}^2 \right)$$

We can write z_t^k and y_t^k as a function of the father

$$z_t^k = G_{zm}^k z_{t-1}^m + G_{ym}^k y_{t-1}^m + g_m^k \omega_{t-1}^m + v_t^k$$

where

$$G_{zm}^k = \frac{1}{2}, G_{ym}^k = \frac{1}{2} \frac{\sigma_z^2}{\sigma_{y^m} \sigma_{y^f}} \rho_{y^m y^f}, g_m^k = \frac{1}{2}$$

and

$$y_t^k = G_{ym}^k y_{t-1}^m + G_{zm}^k z_{t-1}^m + g_m^k \omega_{t-1}^m + v_t^k + x_t^k + u_t^k$$

and we can write z_t^k and y_t^k as a function of the mother

$$z_t^k = G_{zf}^k z_{t-1}^f + G_{yf}^k y_{t-1}^f + g_f^k \omega_{t-1}^f + v_t^k$$

where

$$G_{zf}^k = \frac{1}{2}, G_{yf}^k = \frac{1}{2} \frac{\sigma_z^2}{\sigma_{y^m} \sigma_{y^f}} \rho_{y^m y^f}, g_f^k = \frac{1}{2}$$

and

$$y_t^k = G_{yf}^k y_{t-1}^f + G_{zf}^k z_{t-1}^f + g_f^k \omega_{t-1}^f + v_t^k + x_t^k + u_t^k$$

L.2 Covariances

L.2.1 Main covariances

We use the notation in Figure 1 to denote individuals with different degrees of kinship. We first compute the main covariances (husband-wife, parent-child and siblings). Then, the covariances for other relatives are obtained recursively.

Husband and wife $a - a'$

We have to compute the covariance between "a" and "a'". Let $n' = m, f$ be the gender of a' and $n = m, f$

the gender of the a .

$$Cov(y_{t-1}^{a,n}, y_{t-1}^{a',n'}) = \sigma_{y^m} \sigma_{y^f} \rho_{y^m y^f}$$

Parent-child $aa - a'$

We have to compute the covariance between " aa " and " a' ". Let $n' = m, f$ be the gender of a' and $n^* = m, f$ the gender of the aa . We project aa on a' (his/her father or mother) who has gender n' and we denote by n the gender of the spouse of a'

$$\begin{aligned} Cov(z_t^{aa,n^*}, z_{t-1}^{a',n'}) &= \frac{1}{2} \left(\frac{\sigma_z^2}{\sigma_{y^m} \sigma_{y^f}} \rho_{y^m y^f} + 1 \right) \sigma_z^2 \\ Cov(z_t^{aa,n^*}, y_{t-1}^{a',n'}) &= \frac{1}{2} \left(\frac{\sigma_{y^{n'}}}{\sigma_{y^n}} \rho_{y^m y^f} + 1 \right) \sigma_{z^{n'}}^2 \\ Cov(y_t^{aa,n^*}, z_{t-1}^{a',n'}) &= \frac{1}{2} \left(\frac{\sigma_z^2}{\sigma_{y^m} \sigma_{y^f}} \rho_{y^m y^f} + 1 \right) \sigma_z^2 \\ Cov(y_t^{aa,n^*}, y_{t-1}^{a',n'}) &= \frac{1}{2} \left(\frac{\sigma_{y^{n'}}}{\sigma_{y^n}} \rho_{y^m y^f} + 1 \right) \sigma_{z^{n'}}^2 \end{aligned}$$

Siblings $a' - b$

We have to compute the covariance between " a' " and " b ". Let $n' = m, f$ be the gender of a' and $l = m, f$ the gender of the b . We project a' and b on their father (or mother) $GP2$ who has gender k , and we denote by k' the gender of the mother (or the father)

$$\begin{aligned} Cov(z_{t-1}^{a',n'}, z_{t-1}^{b,l}) &= Cov(G_{y_k}^{n'} y_{t-2}^{GP2,k} + G_{z_k}^{m'} z_{t-2}^{GP2,k} + g_k^{n'} \omega_{t-2}^{GP2,k}, G_{y_k}^l y_{t-2}^{GP2,k} + G_{z_k}^l z_{t-2}^{GP2,k} + g_k^l \omega_{t-2}^{GP2,k}) \\ &= \left(\frac{1}{2} \frac{\sigma_z^2}{\sigma_{y^m} \sigma_{y^f}} \rho_{y^m y^f} \right)^2 \sigma_{y^k}^2 + \frac{1}{4} \sigma_z^2 + \frac{1}{2} \frac{\sigma_z^2}{\sigma_{y^m} \sigma_{y^f}} \rho_{y^m y^f} + \frac{1}{4} \sigma_z^2 \left(1 - \frac{\sigma_z^2}{\sigma_{y^{k'}}^2} \rho_{y^m y^f}^2 \right) \\ &= \frac{1}{2} \left(\frac{\sigma_z^2}{\sigma_{y^m} \sigma_{y^f}} \rho_{y^m y^f} + 1 \right) \sigma_z^2 \\ Cov(z_{t-1}^{a',n'}, y_{t-1}^{b,l}) &= Cov(G_{y_k}^{n'} y_{t-2}^{GP2,k} + G_{z_k}^{m'} z_{t-2}^{GP2,k} + g_k^{n'} \omega_{t-2}^{GP2,k}, G_{y_k}^l y_{t-2}^{GP2,k} + G_{z_k}^l z_{t-2}^{GP2,k} + g_k^l \omega_{t-2}^{GP2,k}) \\ &= \frac{1}{2} \left(\frac{\sigma_z^2}{\sigma_{y^m} \sigma_{y^f}} \rho_{y^m y^f} + 1 \right) \sigma_z^2 \\ Cov(y_{t-1}^{a',n'}, z_{t-1}^{b,l}) &= Cov(G_{y_k}^{n'} y_{t-2}^{GP2,k} + G_{z_k}^{m'} z_{t-2}^{GP2,k} + g_k^{n'} \omega_{t-2}^{GP2,k}, G_{y_k}^l y_{t-2}^{GP2,k} + G_{z_k}^l z_{t-2}^{GP2,k} + g_k^l \omega_{t-2}^{GP2,k}) \\ &= \frac{1}{2} \left(\frac{\sigma_z^2}{\sigma_{y^m} \sigma_{y^f}} \rho_{y^m y^f} + 1 \right) \sigma_z^2 \\ Cov(y_{t-1}^{a',n'}, y_{t-1}^{b,l}) &= Cov(G_{y_k}^{n'} y_{t-2}^{GP2,k} + G_{z_k}^{m'} z_{t-2}^{GP2,k} + g_k^{n'} \omega_{t-2}^{GP2,k} + x_{t-1}^{n'}, G_{y_k}^l y_{t-2}^{GP2,k} + G_{z_k}^l z_{t-2}^{GP2,k} + g_k^l \omega_{t-2}^{GP2,k} + x_{t-1}^l) \\ &= \frac{1}{2} \left(\frac{\sigma_z^2}{\sigma_{y^m} \sigma_{y^f}} \rho_{y^m y^f} + 1 \right) \sigma_z^2 + \sigma_{x^m x^f} \end{aligned}$$

L.2.2 Other covariances

Vertical covariances

Uncle/aunt (siblings of the parents) $aa - b$

We have to compute the covariances between " aa " and " b ". Let $n^* = m, f$ be the gender of aa and $l = m, f$

the gender of the b . We project aa on a' (his/her father or mother) who has gender n'

$$\begin{aligned} Cov(z_t^{aa,n^*}, z_{t-1}^{b,l}) &= Cov(G_{zn'}^{m^*} z_{t-1}^{a',n'} + G_{yn'}^{m^*} y_{t-1}^{a',n'}, z_{t-1}^{b,l}) = \frac{1}{4} \left(\frac{\sigma_z^2}{\sigma_{y^m} \sigma_{y^f}} \rho_{y^m y^f} + 1 \right)^2 \sigma_z^2 \\ Cov(z_t^{aa,n^*}, y_{t-1}^{b,l}) &= Cov(G_{zn'}^{m^*} z_{t-1}^{a',n'} + G_{yn'}^{m^*} y_{t-1}^{a',n'}, y_{t-1}^{b,l}) = \frac{1}{4} \left(\frac{\sigma_z^2}{\sigma_{y^m} \sigma_{y^f}} \rho_{y^m y^f} + 1 \right)^2 \sigma_z^2 \\ Cov(y_t^{aa,n^*}, z_{t-1}^{b,l}) &= Cov(B_{zn'}^{n^*} z_{t-1}^{a',n'} + B_{yn'}^{n^*} y_{t-1}^{a',n'}, z_{t-1}^{b,l}) = \frac{1}{4} \left(\frac{\sigma_z^2}{\sigma_{y^m} \sigma_{y^f}} \rho_{y^m y^f} + 1 \right)^2 \sigma_z^2 \\ Cov(y_t^{aa,n^*}, y_{t-1}^{b,l}) &= Cov(B_{zn'}^{n^*} z_{t-1}^{a',n'} + B_{yn'}^{n^*} y_{t-1}^{a',n'}, y_{t-1}^{b,l}) = \frac{1}{4} \left(\frac{\sigma_z^2}{\sigma_{y^m} \sigma_{y^f}} \rho_{y^m y^f} + 1 \right)^2 \sigma_z^2 + \frac{1}{2} \frac{\sigma_z^2}{\sigma_{y^m} \sigma_{y^f}} \rho_{y^m y^f} \sigma_{x^m x^f} \end{aligned}$$

where a' and b are siblings.

Horizontal covariances

Cousins $aa - bb$

We have to compute the covariances between " aa " and " bb ". Let $n^* = m, f$ be the gender of aa and $l^* = m, f$ the gender of the ay . We project bb on b (his/her father or mother) who has gender l

$$\begin{aligned} Cov(z_t^{aa,n^*}, z_t^{bb,l^*}) &= Cov(z_t^{aa,n^*}, G_{zl}^{l^*} z_{t-1}^{b,l} + G_{yl}^{l^*} y_{t-1}^{b,l}) = \frac{1}{8} \left(\frac{\sigma_z^2}{\sigma_{y^m} \sigma_{y^f}} \rho_{y^m y^f} + 1 \right)^3 \sigma_z^2 \\ Cov(z_t^{aa,n^*}, y_t^{bb,l^*}) &= Cov(z_t^{aa,n^*}, B_{zl}^{l^*} z_{t-1}^{b,l} + B_{yl}^{l^*} y_{t-1}^{b,l}) = \frac{1}{8} \left(\frac{\sigma_z^2}{\sigma_{y^m} \sigma_{y^f}} \rho_{y^m y^f} + 1 \right)^3 \sigma_z^2 \\ Cov(y_t^{aa,n^*}, z_t^{bb,l^*}) &= Cov(y_t^{aa,n^*}, G_{zl}^{l^*} z_{t-1}^{b,l} + G_{yl}^{l^*} y_{t-1}^{b,l}) = \frac{1}{8} \left(\frac{\sigma_z^2}{\sigma_{y^m} \sigma_{y^f}} \rho_{y^m y^f} + 1 \right)^3 \sigma_z^2 \\ Cov(y_t^{aa,n^*}, y_t^{bb,l^*}) &= Cov(y_t^{aa,n^*}, B_{zl}^{l^*} z_{t-1}^{b,l} + B_{yl}^{l^*} y_{t-1}^{b,l}) = \frac{1}{8} \left(\frac{\sigma_z^2}{\sigma_{y^m} \sigma_{y^f}} \rho_{y^m y^f} + 1 \right)^3 \sigma_z^2 + \frac{1}{4} \left(\frac{\sigma_z^2}{\sigma_{y^m} \sigma_{y^f}} \rho_{y^m y^f} \right)^2 \sigma_{x^m x^f} \end{aligned}$$

where b is the uncle/aunt of aa .

L.3 Genetic transmission

Suppose that each person has only one gene with two alleles, A and B . One of the allele is inherited from the father and the other one from the mother. Let X_A and X_B be the random variables representing the potential values each allele may take and suppose that the outcome of interest Y depends on $Z = X_A + X_B$

$$Y = Z + U$$

where U is mean independent of Z .

We have to compute

$$E\left(Z_t \mid Z_{t-1}^m = z^m, Z_{t-1}^f = z^f\right)$$

The distribution of the child Z_t conditional on the parents $X_{A,t-1}^m = x_A^m$, $X_{B,t-1}^m = x_B^m$, $X_{A,t-1}^f = x_A^f$,

$X_{B,t-1}^f = x_B^f$ is multinomial with the following probability mass function

$$Z_t = \begin{cases} x_A^m + x_A^f, & \text{with probability } \frac{1}{4} \\ x_A^m + x_B^f, & \text{with probability } \frac{1}{4} \\ x_B^m + x_A^f, & \text{with probability } \frac{1}{4} \\ x_B^m + x_B^f, & \text{with probability } \frac{1}{4} \end{cases}$$

Then, the distribution of Z_t conditional on $X_{A,t-1}^m = x_A^m$, $Z_{t-1}^m = z^m$, $X_{A,t-1}^f = x_A^f$, $Z_{t-1}^f = z^f$ is also multinomial, and the probability mass function is

$$Z_t = \begin{cases} x_A^m + x_A^f, & \text{with probability } \frac{1}{4} \\ x_A^m + z^f - x_A^f, & \text{with probability } \frac{1}{4} \\ z^m - x_A^m + x_A^f, & \text{with probability } \frac{1}{4} \\ z^m - x_A^m + z^f - x_A^f, & \text{with probability } \frac{1}{4} \end{cases}$$

Then,

$$\begin{aligned} E\left(Z_t \mid X_{A,t-1}^m, Z_{t-1}^m, X_{A,t-1}^f, Z_{t-1}^f\right) &= \frac{1}{4}\left(X_{A,t-1}^m + X_{A,t-1}^f\right) + \frac{1}{4}\left(X_{A,t-1}^m + Z_{t-1}^f - X_{A,t-1}^f\right) \\ &\quad + \frac{1}{4}\left(Z_{t-1}^m - X_{A,t-1}^m + X_{A,t-1}^f\right) + \frac{1}{4}\left(Z_{t-1}^m - X_{A,t-1}^m + Z_{t-1}^f - X_{A,t-1}^f\right) \\ &= \frac{1}{4}Z_{t-1}^f + \frac{1}{4}Z_{t-1}^m + \frac{1}{4}\left(Z_{t-1}^m + Z_{t-1}^f\right) = \frac{1}{2}\left(Z_{t-1}^m + Z_{t-1}^f\right) \end{aligned}$$

Since $E\left(Z_t \mid X_{A,t-1}^m, Z_{t-1}^m, X_{A,t-1}^f, Z_{t-1}^f\right)$ does not depend on $X_{A,t-1}^m$ and $X_{A,t-1}^f$, using the law of iterated expectations

$$E\left(Z_t \mid Z_{t-1}^m, Z_{t-1}^f\right) = \frac{1}{2}\left(Z_{t-1}^m + Z_{t-1}^f\right)$$

If we now consider that each person has n genes, each with two alleles, A_i and B_i . For each gene, one of the allele is inherited from the father and the other one from the mother. Let X_{A_i} and X_{B_i} be the random variables representing the potential values each allele may take and suppose that the outcome of interest Y depends on $Z = \sum_{i=1}^n (X_{A_i} + X_{B_i}) = \sum_{i=1}^n Z_i$, where $Z_i = X_{A_i} + X_{B_i}$. For each gene i , given $X_{A_i,t-1}^m = x_{A_i}^m$, $Z_{i,t-1}^m = z_i^m$, $X_{A_i,t-1}^f = x_{A_i}^f$, there are 4 possible realizations of the child alleles of gene i , and therefore 4^n possible genomes. Then, the distribution of the child Z_t conditional on the parents $X_{A_1,t-1}^m = x_{A_1}^m$, $Z_{1,t-1}^m = z_1^m$, $X_{A_1,t-1}^f = x_{A_1}^f$, $Z_{1,t-1}^f = z_1^f$, ..., $X_{A_n,t-1}^m = x_{A_n}^m$, $Z_{n,t-1}^m = z_n^m$, $X_{A_n,t-1}^f = x_{A_n}^f$,

$Z_{n,t-1}^f = z_n^f$ is also multinomial, and the probability mass function is

$$Z_t = \begin{cases} \left(x_{A_1}^m + x_{A_1}^f \right) + \left(x_{A_2}^m + x_{A_2}^f \right) + \dots + \left(x_{A_n}^m + x_{A_n}^f \right), & \text{with probability } \frac{1}{4^n} \\ \left(x_{A_1}^m + z_1^f - x_{A_1}^f \right) + \left(x_{A_2}^m + x_{A_2}^f \right) + \dots + \left(x_{A_n}^m + x_{A_n}^f \right), & \text{with probability } \frac{1}{4^n} \\ \left(z_1^m - x_{A_1}^m + x_{A_1}^f \right) + \left(x_{A_2}^m + x_{A_2}^f \right) + \dots + \left(x_{A_n}^m + x_{A_n}^f \right), & \text{with probability } \frac{1}{4^n} \\ \left(z_1^m - x_{A_1}^m + z_1^f - x_{A_1}^f \right) + \left(x_{A_2}^m + x_{A_2}^f \right) + \dots + \left(x_{A_n}^m + x_{A_n}^f \right), & \text{with probability } \frac{1}{4^n} \\ \vdots \\ \left(z_1^m - x_{A_1}^m + z_1^f - x_{A_1}^f \right) + \left(z_2^m - x_{A_2}^m + z_2^f - x_{A_2}^f \right) + \dots + \left(z_n^m - x_{A_n}^m + z_n^f - x_{A_n}^f \right), & \text{with probability } \frac{1}{4^n} \end{cases}$$

As in the model with just one gene, all the $x_{A_i}^k$ cancel when we compute the conditional mean

$$\begin{aligned} & E \left(Z_t \mid X_{A_1,t-1}^m, Z_{1,t-1}^m, X_{A_1,t-1}^f, Z_{1,t-1}^f, \dots, X_{A_n,t-1}^m, Z_{n,t-1}^m, X_{A_n,t-1}^f, Z_{n,t-1}^f \right) \\ &= \frac{1}{2} Z_{1,t-1}^m + \dots + \frac{1}{2} Z_{n,t-1}^m + \frac{1}{2} Z_{1,t-1}^f + \dots + \frac{1}{2} Z_{n,t-1}^f = \frac{1}{2} \left(Z_{t-1}^m + Z_{t-1}^f \right) \end{aligned}$$

Then, since the conditional expectation above only depends on Z_{t-1}^m and Z_{t-1}^f , using the law of iterated expectations

$$E \left(Z_t \mid Z_{t-1}^m, Z_{t-1}^f \right) = \frac{1}{2} \left(Z_{t-1}^m + Z_{t-1}^f \right)$$

Let us now consider two siblings i and j . We have to compute

$$E \left(Z_{it} Z_{jt} \mid Z_{t-1}^m = z^m, Z_{t-1}^f = z^f \right)$$

The distribution of $Z_{it} Z_{jt}$ conditional on the parents $X_{A,t-1}^m = x_A^m, X_{B,t-1}^m = x_B^m, X_{A,t-1}^f = x_A^f, X_{B,t-1}^f = x_B^f$ is multinomial with the following probability mass function

$$Z_{it} Z_{jt} = \begin{cases} \left(x_A^m + x_A^f \right)^2, & \text{with probability } \frac{1}{16} \\ \left(x_A^m + x_A^f \right) \left(x_A^m + x_B^f \right), & \text{with probability } \frac{1}{8} \\ \left(x_A^m + x_A^f \right) \left(x_B^m + x_A^f \right), & \text{with probability } \frac{1}{8} \\ \left(x_A^m + x_A^f \right) \left(x_B^m + x_B^f \right), & \text{with probability } \frac{1}{8} \\ \left(x_A^m + x_B^f \right)^2, & \text{with probability } \frac{1}{16} \\ \left(x_A^m + x_B^f \right) \left(x_B^m + x_A^f \right), & \text{with probability } \frac{1}{8} \\ \left(x_A^m + x_B^f \right) \left(x_B^m + x_B^f \right), & \text{with probability } \frac{1}{8} \\ \left(x_B^m + x_A^f \right)^2, & \text{with probability } \frac{1}{16} \\ \left(x_B^m + x_A^f \right) \left(x_B^m + x_B^f \right), & \text{with probability } \frac{1}{8} \\ \left(x_B^m + x_B^f \right)^2, & \text{with probability } \frac{1}{16} \end{cases}$$

Then, the distribution of $Z_{it} Z_{jt}$ conditional on $X_{A,t-1}^m = x_A^m, Z_{t-1}^m = z^m, X_{A,t-1}^f = x_A^f, Z_{t-1}^f = z^f$ is also

multinomial, and the probability mass function is

$$Z_{it}Z_{jt} = \begin{cases} \left(x_A^m + x_A^f\right)^2, & \text{with probability } \frac{1}{16} \\ \left(x_A^m + x_A^f\right)\left(x_A^m + z^f - x_A^f\right), & \text{with probability } \frac{1}{8} \\ \left(x_A^m + x_A^f\right)\left(z^m - x_A^m + x_A^f\right), & \text{with probability } \frac{1}{8} \\ \left(x_A^m + x_A^f\right)\left(z^m - x_A^m + z^f - x_A^f\right), & \text{with probability } \frac{1}{8} \\ \left(x_A^m + z^f - x_A^f\right)^2, & \text{with probability } \frac{1}{16} \\ \left(x_A^m + z^f - x_A^f\right)\left(z^m - x_A^m + x_A^f\right), & \text{with probability } \frac{1}{8} \\ \left(x_A^m + z^f - x_A^f\right)\left(z^m - x_A^m + z^f - x_A^f\right), & \text{with probability } \frac{1}{8} \\ \left(z^m - x_A^m + x_A^f\right)^2, & \text{with probability } \frac{1}{16} \\ \left(z^m - x_A^m + x_A^f\right)\left(z^m - x_A^m + z^f - x_A^f\right), & \text{with probability } \frac{1}{8} \\ \left(z^m - x_A^m + z^f - x_A^f\right)^2, & \text{with probability } \frac{1}{16} \end{cases}$$

Then,

$$\begin{aligned} & E\left(Z_{it}Z_{jt} \mid X_{A,t-1}^m, Z_{t-1}^m, X_{A,t-1}^f, Z_{t-1}^f\right) \\ &= \frac{1}{16} \left(X_A^m + X_A^f\right) \left(\left(X_A^m + X_A^f\right) + \left(X_A^m + Z^f - X_A^f\right) + \left(Z^m - X_A^m + X_A^f\right) + \left(Z^m - X_A^m + Z^f - X_A^f\right)\right) \\ &+ \frac{1}{16} \left(X_A^m + Z^f - X_A^f\right) \left(\left(X_A^m + X_A^f\right) + \left(X_A^m + Z^f - X_A^f\right) + \left(Z^m - X_A^m + X_A^f\right) + \left(Z^m - X_A^m + Z^f - X_A^f\right)\right) \\ &+ \frac{1}{16} \left(Z^m - X_A^m + X_A^f\right) \left(\left(X_A^m + X_A^f\right) + \left(X_A^m + Z^f - X_A^f\right) + \left(Z^m - X_A^m + X_A^f\right) + \left(Z^m - X_A^m + Z^f - X_A^f\right)\right) \\ &+ \frac{1}{16} \left(Z^m - X_A^m + Z^f - X_A^f\right) \left(\left(X_A^m + X_A^f\right) + \left(X_A^m + Z^f - X_A^f\right) + \left(Z^m - X_A^m + X_A^f\right) + \left(Z^m - X_A^m + Z^f - X_A^f\right)\right) \\ &= \frac{1}{8} \left(X_A^m + X_A^f\right) \left(Z^f + Z^m\right) + \frac{1}{8} \left(X_A^m + Z^f - X_A^f\right) \left(Z^f + Z^m\right) \\ &+ \frac{1}{8} \left(Z^m - X_A^m + X_A^f\right) \left(Z^f + Z^m\right) + \frac{1}{8} \left(Z^m - X_A^m + Z^f - X_A^f\right) \left(Z^f + Z^m\right) \\ &= \frac{1}{4} \left(Z_{t-1}^m + Z_{t-1}^f\right)^2 \end{aligned}$$

Since $E\left(Z_{it}Z_{jt} \mid X_{A,t-1}^m, Z_{t-1}^m, X_{A,t-1}^f, Z_{t-1}^f\right)$ does not depend on $X_{A,t-1}^m$ and $X_{A,t-1}^f$, using the law of iterated expectations

$$E\left(Z_{it}Z_{jt} \mid Z_{t-1}^m, Z_{t-1}^f\right) = \frac{1}{4} \left(Z_{t-1}^m + Z_{t-1}^f\right)^2$$

We then have that $E\left(Z_{it}Z_{jt} \mid Z_{t-1}^m, Z_{t-1}^f\right) = E\left(Z_{it} \mid Z_{t-1}^m, Z_{t-1}^f\right) E\left(Z_{jt} \mid Z_{t-1}^m, Z_{t-1}^f\right)$ and Z_{it} and Z_{jt} are uncorrelated conditional on Z_{t-1}^m, Z_{t-1}^f . Then, we can write

$$Z_{it} = \frac{1}{2} \left(Z_{t-1}^m + Z_{t-1}^f\right) + e_{it}$$

where e_{it} and e_{jt} are uncorrelated across siblings.

M The General Model with Two Unobservable Factors

We assume that the value of the output y for an individual from generation t is given by

$$y_t^k = \beta^k \tilde{y}_{t-1}^k + z_t^{G,k} + z_t^{C,k} + x_t^k + u_t^k \quad (\text{M.1})$$

where the superscript k stands for males ($k = m$) and for females ($k = f$). We assume that

$$\tilde{y}_{t-1}^k = \alpha_y^k y_{t-1}^m + (1 - \alpha_y^k) y_{t-1}^f$$

$z_t^{G,k}$ and $z_t^{C,k}$ are two unobservable factors. The genetic factor of the child, $z_t^{G,k}$, depends on the father $z_{t-1}^{G,m}$ as well as on the mother $z_{t-1}^{G,f}$

$$z_t^{G,k} = \frac{z_{t-1}^{G,m} + z_{t-1}^{G,f}}{2} + v_t^{G,k} \quad (\text{M.2})$$

The cultural factor of the child, $z_t^{C,k}$, also depends on the father $z_{t-1}^{C,m}$ as well as on the mother $z_{t-1}^{C,f}$

$$\begin{aligned} z_t^{C,k} &= \gamma^k \tilde{z}_{t-1}^k + e_t^{C,k} + v_t^{C,k} \\ \tilde{z}_{t-1}^k &= \alpha_z^k z_{t-1}^{C,m} + (1 - \alpha_z^k) z_{t-1}^{C,f} \end{aligned} \quad (\text{M.3})$$

Regarding the shocks in model (M.1), we assume that x_t^k , and $e_t^{C,k}$ are shared by all siblings of the same gender, can be correlated across siblings of different gender and are uncorrelated with the other variables (in particular with $z_t^{G,k}$, $z_t^{C,k}$ and y_{t-1}). Finally u_t^k , $v_t^{G,k}$ and $v_t^{C,k}$ are individual's white-noise error terms.

M.1 Assortative mating process

We assume there is assortative mating both in years of schooling and in the cultural factor. In particular we consider the linear projections of $z_{t-1}^{G,f}$, $z_{t-1}^{C,f}$ and y_{t-1}^f on $z_{t-1}^{G,m}$, $z_{t-1}^{C,m}$ and y_{t-1}^m :

$$\begin{aligned} z_{t-1}^{G,f} &= r_{z^G z^G}^m z_{t-1}^{G,m} + r_{z^G z^C}^m z_{t-1}^{C,m} + r_{z^G y}^m y_{t-1}^m + w_{t-1}^{G,m} \\ z_{t-1}^{C,f} &= r_{z^C z^G}^m z_{t-1}^{G,m} + r_{z^C z^C}^m z_{t-1}^{C,m} + r_{z^C y}^m y_{t-1}^m + w_{t-1}^{C,m} \\ y_{t-1}^f &= r_{y z^G}^m z_{t-1}^{G,m} + r_{y z^C}^m z_{t-1}^{C,m} + r_{y y}^m y_{t-1}^m + \varepsilon_{t-1}^m \end{aligned}$$

The coefficients of the linear projections depend on 15 correlations, $\rho_{z^G, m z^C, m}$, $\rho_{z^G, m y^m}$, $\rho_{z^C, m y^m}$, $\rho_{z^G, f z^C, f}$, $\rho_{z^G, f y^f}$, $\rho_{z^C, f y^f}$, $\rho_{z^G, m z^G, f}$, $\rho_{z^G, m z^C, f}$, $\rho_{z^G, m y, f}$, $\rho_{z^C, m z^G, f}$, $\rho_{z^C, m z^C, f}$, $\rho_{z^C, m y, f}$, $\rho_{y^m z^G, f}$, $\rho_{y^m z^C, f}$ and $\rho_{y^m y^f}$, as well as on the standard deviations of $z_{t-1}^{G,k}$, $z_{t-1}^{C,k}$ and y_{t-1}^k , $k = m, f$. However, since we assume there is no assortative mating in the genetic factor, we have that $r_{z^G z^G}^m = r_{z^C z^G}^m = r_{y z^G}^m = 0$, which implies

$$\rho_{z^G, m z^G, f} = \frac{(\rho_{z^G, m y^m} \rho_{z^C, m y^m} - \rho_{z^G, m z^C, m}) \rho_{z^C, m z^G, f} + (\rho_{z^G, m z^C, m} \rho_{z^C, m y^m} - \rho_{z^G, m y^m}) \rho_{y^m z^G, f}}{\rho_{z^C, m y^m}^2 - 1} \quad (\text{M.4})$$

$$\rho_{z^G, m_{z^C}, f} = \frac{(\rho_{z^G, m_{y^m}} \rho_{z^C, m_{y^m}} - \rho_{z^G, m_{z^C}, m}) \rho_{z^C, m_{z^C}, f} + (\rho_{z^G, m_{z^C}, m} \rho_{z^C, m_{y^m}} - \rho_{z^G, m_{y^m}}) \rho_{y^m z^C, f}}{\rho_{z^C, m_{y^m}}^2 - 1}$$

$$\rho_{z^G, m_{y^f}} = \frac{(\rho_{z^G, m_{y^m}} \rho_{z^C, m_{y^m}} - \rho_{z^G, m_{z^C}, m}) \rho_{z^C, m_{y^f}} + (\rho_{z^G, m_{z^C}, m} \rho_{z^C, m_{y^m}} - \rho_{z^G, m_{y^m}}) \rho_{y^m y^f}}{\rho_{z^C, m_{y^m}}^2 - 1}$$

which reduces the number of free correlations to 12.

The remaining coefficients are:

$$r_{z^G z^C}^m = \frac{1}{(1 - \rho_{z^C, m_{y^m}}^2)} \frac{\sigma_{z^G, f}}{\sigma_{z^C, m}} (\rho_{z^C, m_{z^G}, f} - \rho_{z^C, m_{y^m}} \rho_{y^m z^G, f})$$

$$r_{z^G y}^m = \frac{1}{(1 - \rho_{z^C, m_{y^m}}^2)} \frac{\sigma_{z^G, f}}{\sigma_{y^m}} (\rho_{y^m z^G, f} - \rho_{z^C, m_{y^m}} \rho_{z^C, m_{z^G}, f})$$

$$r_{z^C z^C}^m = \frac{1}{(1 - \rho_{z^C, m_{y^m}}^2)} \frac{\sigma_{z^C, f}}{\sigma_{z^C, m}} (\rho_{z^C, m_{z^C}, f} - \rho_{z^C, m_{y^m}} \rho_{y^m z^C, f})$$

$$r_{z^C y}^m = \frac{1}{(1 - \rho_{z^C, m_{y^m}}^2)} \frac{\sigma_{z^C, f}}{\sigma_{y^m}} (\rho_{y^m z^C, f} - \rho_{z^C, m_{y^m}} \rho_{z^C, m_{z^C}, f})$$

$$r_{y z^C}^m = \frac{1}{(1 - \rho_{z^C, m_{y^m}}^2)} \frac{\sigma_{y^f}}{\sigma_{z^C, m}} (\rho_{z^C, m_{y^f}} - \rho_{z^C, m_{y^m}} \rho_{y^m y^f})$$

$$r_{yy}^m = \frac{1}{(1 - \rho_{z^C, m_{y^m}}^2)} \frac{\sigma_{y^f}}{\sigma_{y^m}} (\rho_{y^m y^f} - \rho_{z^C, m_{y^m}} \rho_{z^C, m_{y^f}})$$

We use these matching functions to write the genetic factor, $z_t^{G,k}$, the cultural factor, $z_t^{C,k}$, and years of schooling, y_t^k , as a function of father's genetic factor, $z_{t-1}^{G,m}$, cultural factor, $z_{t-1}^{C,m}$, and years of schooling, y_{t-1}^m . We write (M.2) as

$$\begin{aligned} z_t^{G,k} &= \frac{z_{t-1}^{G,m} + z_{t-1}^{G,f}}{2} + v_t^{G,k} \\ &= \frac{1}{2} \left(z_{t-1}^{G,m} + r_{z^G z^C}^m z_{t-1}^{C,m} + r_{z^G y}^m y_{t-1}^m + w_{t-1}^{G,m} \right) + v_t^{G,k} \\ &= G_{zgm}^k z_{t-1}^{G,m} + G_{zcm}^k z_{t-1}^{C,m} + G_{ym}^k y_{t-1}^m + g_m^k w_{t-1}^{G,m} + v_t^{G,k} \end{aligned}$$

where

$$\begin{aligned} G_{zgm}^k &= \frac{1}{2} \\ G_{zcm}^k &= \frac{1}{2} r_{z^G z^C}^m \\ G_{ym}^k &= \frac{1}{2} r_{z^G y}^m \\ g_m^k &= \frac{1}{2} \end{aligned}$$

(M.3) as

$$z_t^{C,k} = \gamma^k \left(\alpha_z^k z_{t-1}^{C,m} + (1 - \alpha_z^k) z_{t-1}^{C,f} \right) + e_t^{C,k} + v_t^{C,k}$$

$$\begin{aligned}
&= \gamma^k \left(\alpha_z^k z_{t-1}^{C,m} + (1 - \alpha_z^k) \left(r_{z^C z^C}^m z_{t-1}^{C,m} + r_{z^C y}^m y_{t-1}^m + w_{t-1}^{C,m} \right) \right) + e_t^{C,k} + v_t^{C,k} \\
&= C_{zm}^k z_{t-1}^{C,m} + C_{ym}^k y_{t-1}^m + c_m^k \omega_{t-1}^{C,m} + e_t^{C,k} + v_t^{C,k}
\end{aligned}$$

where

$$\begin{aligned}
C_{zm}^k &= \gamma^k (\alpha_z^k + (1 - \alpha_z^k) r_{z^C z^C}^m) \\
C_{ym}^k &= \gamma^k (1 - \alpha_z^k) r_{z^C y}^m \\
c_m^k &= \gamma^k (1 - \alpha_z^k)
\end{aligned}$$

and (M.1) as

$$y_t^k = \beta^k \left(\alpha_y^k y_{t-1}^m + (1 - \alpha_y^k) y_{t-1}^f \right) + z_t^{G,k} + z_t^{C,k} + x_t^k + u_t^k$$

$$\begin{aligned}
y_t^k &= \beta^k \left(\alpha_y^k y_{t-1}^m + (1 - \alpha_y^k) y_{t-1}^f \right) + z_t^{G,k} + z_t^{C,k} + x_t^k + u_t^k \\
&= \beta^k \left(\alpha_y^k y_{t-1}^m + (1 - \alpha_y^k) \left(r_{yz^C}^m z_{t-1}^{C,m} + r_{yy}^m y_{t-1}^m + \varepsilon_{t-1}^m \right) \right) \\
&\quad \frac{1}{2} z_{t-1}^{G,m} + \frac{1}{2} r_{z^G z^C}^m z_{t-1}^{C,m} + \frac{1}{2} r_{z^G y}^m y_{t-1}^m + \frac{1}{2} w_{t-1}^{G,m} + v_t^{G,k} \\
&\quad C_{zm}^k z_{t-1}^{C,m} + C_{ym}^k y_{t-1}^m + c_m^k \omega_{t-1}^{C,m} + e_t^{C,k} + v_t^{C,k} + x_t^k + u_t^k
\end{aligned}$$

$$\begin{aligned}
y_t^k &= B_{zgm}^k z_{t-1}^{G,m} + B_{zm}^k z_{t-1}^{C,m} + B_{ym}^k y_{t-1}^m + g_m^k w_{t-1}^{G,m} + c_m^k \omega_{t-1}^{C,m} + b_m^k \varepsilon_{t-1}^m \\
&\quad + e_t^{G,k} + e_t^{C,k} + x_t^k + v_t^{G,k} + v_t^{C,k} + u_t^k
\end{aligned}$$

where

$$\begin{aligned}
B_{zgm}^k &= \frac{1}{2} \\
B_{zm}^k &= \beta^k (1 - \alpha_y^k) r_{yz^C}^m + \frac{1}{2} r_{z^G z^C}^m + C_{zm}^k \\
B_{ym}^k &= \beta^k (\alpha_y^k + (1 - \alpha_y^k) r_{yy}^m) + \frac{1}{2} r_{z^G y}^m + C_{ym}^k \\
b_m^k &= \beta^k (1 - \alpha_y^k)
\end{aligned}$$

All these expressions will be used to compute correlations between relatives that are related through their fathers.

Analogously, we can compute the linear projections of $z_{t-1}^{G,m}$, $z_{t-1}^{C,m}$ and y_{t-1}^m on $z_{t-1}^{G,f}$, $z_{t-1}^{C,f}$ and y_{t-1}^f . The assumption of no assortative mating in the genetic factor implies $r_{z^G z^G}^f = r_{z^C z^C}^f = r_{y z^G}^f = 0$

$$\rho_{z^G, m z^G, f} = \frac{(\rho_{z^G, f y^f} \rho_{z^C, f y^f} - \rho_{z^G, f z^C, f}) \rho_{z^G, m z^C, f} + (\rho_{z^G, f z^C, f} \rho_{z^C, f y^f} - \rho_{z^G, f y^f}) \rho_{z^G, m y^f}}{\rho_{z^C, f y^f}^2 - 1} \quad (\text{M.5})$$

$$\rho_{z^C, m, z^G, f} = \frac{(\rho_{z^G, f, y^f} \rho_{z^C, f, y^f} - \rho_{z^G, f, z^C, f}) \rho_{z^C, m, z^C, f} + (\rho_{z^G, f, z^C, f} \rho_{z^C, f, y^f} - \rho_{z^G, f, y^f}) \rho_{z^C, m, y^f}}{\rho_{z^C, f, y^f}^2 - 1}$$

$$\rho_{y^m, z^G, f} = \frac{(\rho_{z^G, f, y^f} \rho_{z^C, f, y^f} - \rho_{z^G, f, z^C, f}) \rho_{y^m, z^C, f} + (\rho_{z^G, f, z^C, f} \rho_{z^C, f, y^f} - \rho_{z^G, f, y^f}) \rho_{y^m, y^f}}{\rho_{z^C, f, y^f}^2 - 1}$$

The definitions of $\rho_{z^G, m, z^G, f}$ in (M.4) and (M.5) turn to be identical and therefore the the number of free correlations is reduced to 10. We can then write the genetic factor, $z_t^{G, k}$, the cultural factor, $z_t^{C, k}$, and years of schooling, y_t^k , as a function of mother's genetic factor, $z_{t-1}^{G, f}$, cultural factor, $z_{t-1}^{C, f}$, and years of schooling, y_{t-1}^f . These expressions will be used to compute correlations between relatives that are related through their mothers.

M.2 Steady state assumption

We assume that the second order moments of all variables are time invariant. This steady state assumption implies that $\rho_{z^C, m, z^G, m}$, ρ_{z^C, m, y^m} , ρ_{z^G, m, y^m} , $\rho_{z^C, f, z^G, f}$, ρ_{z^C, f, y^f} , and ρ_{z^G, f, y^f} depend on the remaining parameters of the model as shown below.

We first compute $\rho_{z^G, m, z^C, m}$

$$\begin{aligned} Cov(z_t^{C, m}, z_t^{G, m}) &= Cov\left(\gamma^m \alpha_z^m z_{t-1}^{C, m} + \gamma^m (1 - \alpha_z^m) z_{t-1}^{C, f}, \frac{1}{2} z_{t-1}^{G, m} + \frac{1}{2} z_{t-1}^{G, f}\right) \\ &= \gamma^m \alpha_z^m \frac{1}{2} Cov(z_{t-1}^{C, m}, z_{t-1}^{G, m}) + \gamma^m \alpha_z^m \frac{1}{2} Cov(z_{t-1}^{C, m}, z_{t-1}^{G, f}) \\ &\quad + \gamma^m (1 - \alpha_z^m) \frac{1}{2} Cov(z_{t-1}^{C, f}, z_{t-1}^{G, m}) + \gamma^m (1 - \alpha_z^m) \frac{1}{2} Cov(z_{t-1}^{C, f}, z_{t-1}^{G, f}) \end{aligned}$$

and dividing by $\sigma_{z^C, m}$ and $\sigma_{z^G, m}$ and rearranging we have

$$\begin{aligned} &\left(1 - \gamma^m \alpha_z^m \frac{1}{2}\right) \rho_{z^G, m, z^C, m} - \gamma^m (1 - \alpha_z^m) \frac{1}{2} \frac{\sigma_{z^C, f}}{\sigma_{z^C, m}} \frac{\sigma_{z^G, f}}{\sigma_{z^G, m}} \rho_{z^C, f, z^G, f} \\ &= \gamma^m \alpha_z^m \frac{1}{2} \frac{\sigma_{z^G, f}}{\sigma_{z^G, m}} \rho_{z^C, m, z^G, f} + \gamma^m (1 - \alpha_z^m) \frac{1}{2} \frac{\sigma_{z^C, f}}{\sigma_{z^C, m}} \rho_{z^G, m, z^C, f} \end{aligned}$$

analogously we obtain another equation from the steady state assumption on $\rho_{z^G, f, z^C, f}$

$$\begin{aligned} &\left(1 - \frac{1}{2} \gamma^f (1 - \alpha_z^f)\right) \rho_{z^G, f, z^C, f} - \frac{1}{2} \gamma^f \alpha_z^f \frac{\sigma_{z^C, m}}{\sigma_{z^C, f}} \frac{\sigma_{z^G, m}}{\sigma_{z^G, f}} \rho_{z^G, m, z^C, m} \\ &= \frac{1}{2} \gamma^f (1 - \alpha_z^f) \frac{\sigma_{z^G, m}}{\sigma_{z^G, f}} \rho_{z^G, m, z^C, f} + \frac{1}{2} \gamma^f \alpha_z^f \frac{\sigma_{z^C, m}}{\sigma_{z^C, f}} \rho_{z^C, m, z^G, f} \end{aligned}$$

We now compute ρ_{z^G, m, y^m}

$$\begin{aligned} Cov(y_t^m, z_t^{G, m}) &= Cov\left(\beta^m \tilde{y}_{t-1}^m + z_t^{G, m} + z_t^{C, m}, z_t^{G, m}\right) = Cov\left(\beta^m \alpha_y^m y_{t-1}^m + \beta^m (1 - \alpha_y^m) y_{t-1}^f, \frac{1}{2} z_{t-1}^{G, m} + \frac{1}{2} z_{t-1}^{G, f}\right) \\ &\quad + \sigma_{z^G, m}^2 + Cov(z_t^{C, m}, z_t^{G, m}) \\ &= \beta^m \alpha_y^m \frac{1}{2} Cov(y_{t-1}^m, z_{t-1}^{G, m}) + \beta^m \alpha_y^m \frac{1}{2} Cov(y_{t-1}^m, z_{t-1}^{G, f}) + \beta^m (1 - \alpha_y^m) \frac{1}{2} Cov(y_{t-1}^f, z_{t-1}^{G, m}) \end{aligned}$$

$$+\beta^m(1-\alpha_y^m)\frac{1}{2}\text{Cov}\left(y_{t-1}^f, z_{t-1}^{G,f}\right) + \sigma_{z^{G,m}}^2 + \text{Cov}\left(z_t^{C,m}, z_t^{G,m}\right)$$

and dividing by σ_{y^m} and $\sigma_{z^{G,m}}$ and rearranging we have

$$\begin{aligned} & \left(1 - \frac{1}{2}\beta^m\alpha_y^m\right)\rho_{z^{G,m}y^m} - \frac{1}{2}\beta^m(1-\alpha_y^m)\frac{\sigma_{y^f}}{\sigma_{y^m}}\frac{\sigma_{z^{G,f}}}{\sigma_{z^{G,m}}}\rho_{z^{G,f}y^f} \\ = & \frac{\sigma_{z^{C,m}}}{\sigma_{y^m}}\rho_{z^{G,m}z^{C,m}} + \frac{1}{2}\beta^m\alpha_y^m\frac{\sigma_{z^{G,f}}}{\sigma_{z^{G,m}}}\rho_{y^m z^{G,f}} + \frac{1}{2}\beta^m(1-\alpha_y^m)\frac{\sigma_{y^f}}{\sigma_{y^m}}\rho_{z^{G,m}y^f} + \frac{\sigma_{z^{G,m}}}{\sigma_{y^m}} \end{aligned}$$

analogously we obtain another equation from the steady state assumption on $\rho_{z^{G,f}y^f}$

$$\begin{aligned} & \left(1 - \frac{1}{2}\beta^f(1-\alpha_y^f)\right)\rho_{z^{G,f}y^f} - \frac{1}{2}\beta^f\alpha_y^f\frac{\sigma_{y^m}}{\sigma_{y^f}}\frac{\sigma_{z^{G,m}}}{\sigma_{z^{G,f}}}\rho_{z^{G,m}y^m} \\ = & \frac{\sigma_{z^{C,f}}}{\sigma_{y^f}}\rho_{z^{G,f}z^{C,f}} + \frac{1}{2}\beta^f(1-\alpha_y^f)\frac{\sigma_{z^{G,m}}}{\sigma_{z^{G,f}}}\rho_{y^f z^{G,m}} + \frac{1}{2}\beta^f\alpha_y^f\frac{\sigma_{y^m}}{\sigma_{y^f}}\rho_{z^{G,f}y^m} + \frac{\sigma_{z^{G,f}}}{\sigma_{y^f}} \end{aligned}$$

We finally compute $\rho_{z^{C,m}y^m}$

$$\begin{aligned} \text{Cov}(y_t^m, z_t^{C,m}) &= \text{Cov}(\beta^m\tilde{y}_{t-1}^m + z_t^{G,m} + z_t^{C,m}, z_t^{C,m}) \\ &= \text{Cov}\left(\beta^m\alpha_y^m y_{t-1}^m + \beta^m(1-\alpha_y^m)y_{t-1}^f, \gamma^m\alpha_z^k z_{t-1}^{C,m} + \gamma^m(1-\alpha_z^k)z_{t-1}^{C,f}\right) \\ &\quad + \text{Cov}\left(z_t^{C,m}, z_t^{G,m}\right) + \sigma_{z^{C,m}}^2 \\ &= \beta^m\alpha_y^m\gamma^m\alpha_z^m\text{Cov}\left(y_{t-1}^m, z_{t-1}^{C,m}\right) + \beta^m\alpha_y^m\gamma^m(1-\alpha_z^k)\text{Cov}\left(y_{t-1}^m, z_{t-1}^{C,f}\right) \\ &\quad + \beta^m(1-\alpha_y^m)\gamma^m\alpha_z^k\text{Cov}\left(y_{t-1}^f, z_{t-1}^{C,m}\right) \\ &\quad + \beta^m(1-\alpha_y^m)\gamma^m(1-\alpha_z^k)\text{Cov}\left(y_{t-1}^f, z_{t-1}^{C,f}\right) + \text{Cov}\left(z_t^{C,m}, z_t^{G,m}\right) + \sigma_{z^{C,m}}^2 \end{aligned}$$

and dividing by σ_{y^m} and $\sigma_{z^{C,m}}$ and rearranging we have

$$\begin{aligned} & \left(1 - \beta^m\alpha_y^m\gamma^m\alpha_z^m\right)\rho_{z^{C,m}y^m} - \beta^m(1-\alpha_y^m)\gamma^m(1-\alpha_z^m)\frac{\sigma_{z^{C,f}}}{\sigma_{z^{C,m}}}\frac{\sigma_{y^f}}{\sigma_{y^m}}\rho_{z^{C,f}y^f} \\ = & \frac{\sigma_{z^{G,m}}}{\sigma_{y^m}}\rho_{z^{G,m}z^{C,m}} + \beta^m\alpha_y^m\gamma^m(1-\alpha_z^m)\frac{\sigma_{z^{C,f}}}{\sigma_{z^{C,m}}}\rho_{y^m z^{C,f}} + \beta^m(1-\alpha_y^m)\gamma^m\alpha_z^m\frac{\sigma_{y^f}}{\sigma_{y^m}}\rho_{z^{C,m}y^f} + \frac{\sigma_{z^{C,m}}}{\sigma_{y^m}} \end{aligned}$$

analogously we obtain another equation from the steady state assumption on $\rho_{z^{C,f}y^f}$

$$\begin{aligned} & \left(1 - \beta^f(1-\alpha_y^f)\gamma^f\alpha_z^f\right)\rho_{z^{C,f}y^f} - \beta^f\alpha_y^f\gamma^f\alpha_z^f\frac{\sigma_{z^{C,m}}}{\sigma_{z^{C,f}}}\frac{\sigma_{y^m}}{\sigma_{y^f}}\rho_{z^{C,m}y^m} \\ = & \frac{\sigma_{z^{G,f}}}{\sigma_{y^f}}\rho_{z^{G,f}z^{C,f}} + \beta^f(1-\alpha_y^f)\gamma^f\alpha_z^f\frac{\sigma_{z^{C,m}}}{\sigma_{z^{C,f}}}\rho_{y^f z^{C,m}} + \beta^f\alpha_y^f\gamma^f(1-\alpha_z^f)\frac{\sigma_{y^m}}{\sigma_{y^f}}\rho_{z^{C,f}y^m} + \frac{\sigma_{z^{C,f}}}{\sigma_{y^f}} \end{aligned}$$

The six equations for the steady state reduce the number of free correlations to four: $\rho_{z^{C,m}z^{C,f}}$, $\rho_{z^{C,m}y^f}$, $\rho_{y^m z^{C,f}}$, and $\rho_{y^m y^f}$. Then, this model has 21 parameters: $\beta^k, \gamma^k, \sigma_{z^{G,k}}, \sigma_{z^{C,k}}, \sigma_{x^k}^2, \sigma_{e^{C,k}}^2, \alpha_y^k, \alpha_z^k, k = m, f, \sigma_{x^m x^f}, \sigma_{e^{C,m} e^{C,f}}, \rho_{z^{C,m} z^{C,f}}, \rho_{z^{C,m} y^f}, \rho_{y^m z^{C,f}}$, and $\rho_{y^m y^f}$, just one parameter more than the one factor model.

M.3 Main covariances

We first compute the main covariances (husband-wife, parent-child and siblings). Then, the covariances for other relatives are obtained recursively. We again use the notation in Figure 1 to denote individuals with different degrees of kinship.

Husband and wife $a - a'$

We have to compute the covariance between "a" and "a'". Let $n' = m, f$ be the gender of "a'" and $n = f, m$ the gender of "a"

$$Cov(y_{t-1}^{a,n}, y_{t-1}^{a',n'}) = \sigma_{y^m} \sigma_{y^f} \rho_{y^m y^f}$$

Parent-child $aa - a'$

We have to compute the covariance between "aa" and "a'". Let $n' = m, f$ be the gender of a' and $n^* = f, m$ the gender of aa . We project aa on a' (his/her father or mother).

$$\begin{aligned} Cov(z_t^{G,aa,n^*}, z_{t-1}^{G,a',n'}) &= Cov(G_{zgn'}^{n^*} z_{t-1}^{G,a',n'} + G_{zn'}^{n^*} z_{t-1}^{C,a',n'} + G_{yn'}^{n^*} y_{t-1}^{a',n'}, z_{t-1}^{G,a',n'}) \\ &= G_{zgn'}^{n^*} \sigma_{z^{G,n'}}^2 + G_{zn'}^{n^*} Cov(z_{t-1}^{C,a',n'}, z_{t-1}^{G,a',n'}) + G_{yn'}^{n^*} Cov(y_{t-1}^{a',n'}, z_{t-1}^{G,a',n'}) \end{aligned}$$

$$\begin{aligned} Cov(z_t^{G,aa,n^*}, z_{t-1}^{C,a',n'}) &= Cov(G_{zgn'}^{n^*} z_{t-1}^{G,a',n'} + G_{zn'}^{n^*} z_{t-1}^{C,a',n'} + G_{yn'}^{n^*} y_{t-1}^{a',n'}, z_{t-1}^{C,a',n'}) \\ &= G_{zgn'}^{n^*} Cov(z_{t-1}^{G,a',n'}, z_{t-1}^{C,a',n'}) + G_{zn'}^{n^*} \sigma_{z^{C,n'}}^2 + G_{yn'}^{n^*} Cov(y_{t-1}^{a',n'}, z_{t-1}^{C,a',n'}) \end{aligned}$$

$$\begin{aligned} Cov(z_t^{G,aa,n^*}, y_{t-1}^{a',n'}) &= Cov(G_{zgn'}^{n^*} z_{t-1}^{G,a',n'} + G_{zn'}^{n^*} z_{t-1}^{C,a',n'} + G_{yn'}^{n^*} y_{t-1}^{a',n'}, y_{t-1}^{a',n'}) \\ &= G_{zgn'}^{n^*} Cov(z_{t-1}^{G,a',n'}, y_{t-1}^{a',n'}) + G_{zn'}^{n^*} Cov(z_{t-1}^{C,a',n'}, y_{t-1}^{a',n'}) + G_{yn'}^{n^*} \sigma_{y^{n'}}^2 \end{aligned}$$

$$\begin{aligned} Cov(z_t^{C,aa,n^*}, z_{t-1}^{G,a',n'}) &= Cov(C_{zn'}^{n^*} z_{t-1}^{C,a',n'} + C_{yn'}^{n^*} y_{t-1}^{a',n'}, z_{t-1}^{G,a',n'}) \\ &= C_{zn'}^{n^*} Cov(z_{t-1}^{C,a',n'}, z_{t-1}^{G,a',n'}) + C_{yn'}^{n^*} Cov(y_{t-1}^{a',n'}, z_{t-1}^{G,a',n'}) \end{aligned}$$

$$\begin{aligned} Cov(z_t^{C,aa,n^*}, z_{t-1}^{C,a',n'}) &= Cov(C_{zn'}^{n^*} z_{t-1}^{C,a',n'} + C_{yn'}^{n^*} y_{t-1}^{a',n'}, z_{t-1}^{C,a',n'}) \\ &= C_{zn'}^{n^*} \sigma_{z^{C,n'}}^2 + C_{yn'}^{n^*} Cov(y_{t-1}^{a',n'}, z_{t-1}^{C,a',n'}) \end{aligned}$$

$$\begin{aligned} Cov(z_t^{C,aa,n^*}, y_{t-1}^{a',n'}) &= Cov(C_{zn'}^{n^*} z_{t-1}^{C,a',n'} + C_{yn'}^{n^*} y_{t-1}^{a',n'}, y_{t-1}^{a',n'}) \\ &= C_{zn'}^{n^*} Cov(z_{t-1}^{C,a',n'}, y_{t-1}^{a',n'}) + C_{yn'}^{n^*} \sigma_{y^{n'}}^2 \end{aligned}$$

$$\begin{aligned}
Cov(y_t^{aa,n^*}, z_{t-1}^{G,a',n'}) &= Cov(B_{zgn'}^* z_{t-1}^{G,a',n'} + B_{zn'}^* z_{t-1}^{C,a',n'} + B_{yn'}^* y_{t-1}^{a',n'}, z_{t-1}^{G,a',n'}) \\
&= B_{zgn'}^* \sigma_{zG,n'}^2 + B_{zn'}^* Cov(z_{t-1}^{C,a',n'}, z_{t-1}^{G,a',n'}) + B_{yn'}^* Cov(y_{t-1}^{a',n'}, z_{t-1}^{G,a',n'})
\end{aligned}$$

$$\begin{aligned}
Cov(y_t^{aa,n^*}, z_{t-1}^{C,a',n'}) &= Cov(B_{zgn'}^* z_{t-1}^{G,a',n'} + B_{zn'}^* z_{t-1}^{C,a',n'} + B_{yn'}^* y_{t-1}^{a',n'}, z_{t-1}^{C,a',n'}) \\
&= B_{zgn'}^* Cov(z_{t-1}^{G,a',n'}, z_{t-1}^{C,a',n'}) + B_{zn'}^* \sigma_{zC,n'}^2 + B_{yn'}^* Cov(y_{t-1}^{a',n'}, z_{t-1}^{C,a',n'})
\end{aligned}$$

$$\begin{aligned}
Cov(y_t^{aa,n^*}, y_{t-1}^{a',n'}) &= Cov(B_{zgn'}^* z_{t-1}^{G,a',n'} + B_{zn'}^* z_{t-1}^{C,a',n'} + B_{yn'}^* y_{t-1}^{a',n'}, y_{t-1}^{a',n'}) \\
&= B_{zgn'}^* Cov(z_{t-1}^{G,a',n'}, y_{t-1}^{a',n'}) + B_{zn'}^* Cov(z_{t-1}^{C,a',n'}, y_{t-1}^{a',n'}) + B_{yn'}^* \sigma_{y_n'}^2
\end{aligned}$$

Siblings $a' - b$

We have to compute the covariance between "a'" and "b". Let $n', l = m, f$ be the genders of the siblings.

We can compute the covariances projecting on the father ($k = m$) or on the mother ($k = f$).

$$\begin{aligned}
Cov(z_t^{G,a',n'}, z_t^{G,b,l}) &= G_{zGk}^{n'} G_{zGk}^{l} \sigma_{zG,k}^2 + G_{zGk}^{n'} G_{zGk}^{l} \sigma_{zC,k}^2 + G_{yGk}^{n'} G_{yGk}^{l} \sigma_{yG,k}^2 + \left(G_{zGk}^{n'} G_{zGk}^{l} + G_{zGk}^{n'} G_{zGk}^{l} \right) Cov(z_{t-1}^{G,a',k}, z_{t-1}^{C,a',k}) \\
&+ \left(G_{zGk}^{n'} G_{yGk}^{l} + G_{yGk}^{n'} G_{zGk}^{l} \right) Cov(z_{t-1}^{G,a',k}, y_{t-1}^{a',k}) + \left(G_{zGk}^{n'} G_{yGk}^{l} + G_{yGk}^{n'} G_{zGk}^{l} \right) Cov(z_{t-1}^{C,a',k}, y_{t-1}^{a',k}) + g_k^{n'} g_k^{l} \sigma_{wG,k}^2
\end{aligned}$$

$$\begin{aligned}
Cov(z_t^{G,a',n'}, z_t^{C,b,l}) &= G_{zGk}^{n'} C_{zGk}^{l} \sigma_{zC,k}^2 + G_{yGk}^{n'} C_{yGk}^{l} \sigma_{yG,k}^2 + G_{zGk}^{n'} C_{zGk}^{l} Cov(z_{t-1}^{G,a',k}, z_{t-1}^{C,a',k}) + G_{zGk}^{n'} C_{yGk}^{l} Cov(z_{t-1}^{G,a',k}, y_{t-1}^{a',k}) \\
&+ \left(G_{zGk}^{n'} C_{yGk}^{l} + G_{yGk}^{n'} C_{zGk}^{l} \right) Cov(z_{t-1}^{C,a',k}, y_{t-1}^{a',k}) + g_k^{n'} c_k^l Cov(w_{t-1}^{G,k}, \omega_{t-1}^{C,k})
\end{aligned}$$

$$\begin{aligned}
Cov(z_t^{G,a',n'}, y_t^{b,l}) &= G_{zGk}^{n'} B_{zGk}^{l} \sigma_{zG,k}^2 + G_{zGk}^{n'} B_{zGk}^{l} \sigma_{zC,k}^2 + G_{yGk}^{n'} B_{yGk}^{l} \sigma_{yG,k}^2 + \left(G_{zGk}^{n'} B_{zGk}^{l} + G_{zGk}^{n'} B_{zGk}^{l} \right) Cov(z_{t-1}^{G,a',k}, z_{t-1}^{C,a',k}) \\
&+ \left(G_{zGk}^{n'} B_{yGk}^{l} + G_{yGk}^{n'} B_{zGk}^{l} \right) Cov(z_{t-1}^{G,a',k}, y_{t-1}^{a',k}) + \left(G_{zGk}^{n'} B_{yGk}^{l} + G_{yGk}^{n'} B_{zGk}^{l} \right) Cov(z_{t-1}^{C,a',k}, y_{t-1}^{a',k}) \\
&+ g_k^{n'} g_k^l \sigma_{wG,k}^2 + g_k^{n'} c_k^l Cov(w_{t-1}^{G,k}, \omega_{t-1}^{C,k}) + g_k^{n'} b_k^l Cov(w_{t-1}^{G,k}, \varepsilon_{t-1}^k)
\end{aligned}$$

$$\begin{aligned}
Cov(z_t^{C,a',n'}, z_t^{G,b,l}) &= C_{zGk}^{n'} G_{zGk}^{l} \sigma_{zC,k}^2 + C_{yGk}^{n'} G_{yGk}^{l} \sigma_{yG,k}^2 + C_{zGk}^{n'} G_{zGk}^{l} Cov(z_{t-1}^{G,a',k}, z_{t-1}^{C,a',k}) + C_{yGk}^{n'} G_{zGk}^{l} Cov(z_{t-1}^{G,a',k}, y_{t-1}^{a',k}) \\
&+ \left(C_{zGk}^{n'} G_{yGk}^{l} + C_{yGk}^{n'} G_{zGk}^{l} \right) (z_{t-1}^{C,a',k}, y_{t-1}^{a',k}) + c_k^{n'} g_k^l Cov(w_{t-1}^{G,k}, \omega_{t-1}^{C,k})
\end{aligned}$$

$$Cov(z_t^{C,a',n'}, z_t^{C,b,l}) = c_{zGk}^{n'} C_{zGk}^{l} \sigma_{zC,k}^2 + c_{yGk}^{n'} C_{yGk}^{l} \sigma_{yG,k}^2 + \left(C_{zGk}^{n'} C_{yGk}^{l} + C_{yGk}^{n'} C_{zGk}^{l} \right) cov(z_{t-1}^{C,a',k}, y_{t-1}^{a',k}) + c_k^{n'} c_k^l \sigma_{wC,k}^2 + \sigma_{ec,n'ec,l}$$

$$\begin{aligned}
Cov(z_t^{C,a',n'}, y_t^{b,l}) &= C_{zGk}^{n'} B_{zGk}^{l} \sigma_{zC,k}^2 + C_{yGk}^{n'} B_{yGk}^{l} \sigma_{yG,k}^2 + C_{zGk}^{n'} B_{zGk}^{l} Cov(z_{t-1}^{G,a',k}, z_{t-1}^{C,a',k}) + C_{yGk}^{n'} B_{zGk}^{l} Cov(z_{t-1}^{G,a',k}, y_{t-1}^{a',k}) \\
&+ \left(C_{zGk}^{n'} B_{yGk}^{l} + C_{yGk}^{n'} B_{zGk}^{l} \right) cov(z_{t-1}^{C,a',k}, y_{t-1}^{a',k}) + c_k^{n'} g_k^l Cov(w_{t-1}^{C,k}, \omega_{t-1}^{G,k}) + c_k^{n'} c_k^l \sigma_{wC,k}^2 + c_k^{n'} b_k^l Cov(w_{t-1}^{C,k}, \varepsilon_{t-1}^k) + \sigma_{ec,n'ec,l}
\end{aligned}$$

$$\begin{aligned}
Cov(y_t^{a',n'}, z_t^{G,b,l}) &= B_{zGk}^{n'} G_{zGk}^{l} \sigma_{zG,k}^2 + B_{zGk}^{n'} G_{zGk}^{l} \sigma_{zC,k}^2 + B_{yGk}^{n'} G_{yGk}^{l} \sigma_{yG,k}^2 + \left(B_{zGk}^{n'} G_{zGk}^{l} + B_{zGk}^{n'} G_{zGk}^{l} \right) Cov(z_{t-1}^{G,a',k}, z_{t-1}^{C,a',k}) \\
&+ \left(B_{zGk}^{n'} G_{yGk}^{l} + B_{yGk}^{n'} G_{zGk}^{l} \right) Cov(z_{t-1}^{G,a',k}, y_{t-1}^{a',k}) + \left(B_{zGk}^{n'} G_{yGk}^{l} + B_{yGk}^{n'} G_{zGk}^{l} \right) Cov(z_{t-1}^{C,a',k}, y_{t-1}^{a',k}) \\
&+ g_m^{n'} g_k^l \sigma_{wG,k}^2 + c_k^{n'} g_k^l Cov(w_{t-1}^{C,m}, \omega_{t-1}^{G,k}) + b_m^{n'} g_k^l Cov(\varepsilon_{t-1}^m, \omega_{t-1}^{G,k})
\end{aligned}$$

$$\begin{aligned}
Cov(y_t^{a',n'}, z_t^{C,b,l}) &= B_{zGk}^{n'} C_{zGk}^{l} \sigma_{zC,k}^2 + B_{yGk}^{n'} C_{yGk}^{l} \sigma_{yG,k}^2 + B_{zGk}^{n'} C_{zGk}^{l} Cov(z_{t-1}^{G,a',k}, z_{t-1}^{C,a',k}) + B_{zGk}^{n'} C_{yGk}^{l} Cov(z_{t-1}^{G,a',k}, y_{t-1}^{a',k}) \\
&+ \left(B_{zGk}^{n'} C_{yGk}^{l} + B_{yGk}^{n'} C_{zGk}^{l} \right) Cov(z_{t-1}^{C,a',k}, y_{t-1}^{a',k}) + g_k^{n'} c_k^l Cov(w_{t-1}^{G,k}, \omega_{t-1}^{C,k}) \\
&+ c_k^{n'} c_k^l \sigma_{wC,k}^2 + b_k^{n'} c_k^l Cov(\varepsilon_{t-1}^m, \omega_{t-1}^{C,k}) + \sigma_{ec,n'ec,l}
\end{aligned}$$

$$\begin{aligned}
Cov(y_t^{a',n'}, y_t^{b,l}) &= B_{z_gk}^{n'} B_{z_gk}^l \sigma_{zG,k}^2 + B_{z_k}^{n'} B_{z_k}^l \sigma_{zC,k}^2 + B_{y_k}^{n'} B_{y_k}^l \sigma_{y^k}^2 + \left(B_{z_gk}^{n'} B_{z_k}^l + B_{z_k}^{n'} B_{z_gk}^l \right) Cov(z_{t-1}^{G,a',k}, z_{t-1}^{C,a',k}) \\
&+ \left(B_{z_gk}^{n'} B_{y_k}^l + B_{y_k}^{n'} B_{z_gk}^l \right) cov(z_{t-1}^{G,a',k}, y_{t-1}^{a',k}) + \left(B_{z_k}^{n'} B_{y_k}^l + B_{y_k}^{n'} B_{z_k}^l \right) cov(z_{t-1}^{C,a',k}, y_{t-1}^{a',k}) + b_k^{n'} b_k^l \sigma_{\varepsilon^k}^2 + g_k^{n'} g_k^l \sigma_{wG,k}^2 \\
&+ c_k^{n'} c_k^l \sigma_{wC,k}^2 + \left(g_k^{n'} c_k^l + c_k^{n'} g_k^l \right) Cov(\omega_{t-1}^{G,k}, \omega_{t-1}^{C,k}) + \left(b_k^{n'} g_k^l + g_k^{n'} b_k^l \right) Cov(\omega_{t-1}^{G,k}, \varepsilon_{t-1}^m) \\
&+ \left(b_k^{n'} c_k^l + c_k^{n'} b_k^l \right) Cov(\omega_{t-1}^{C,k}, \varepsilon_{t-1}^m) + \sigma_{eC,n'} \sigma_{eC,l} + \sigma_{x^{n'} x^l}
\end{aligned}$$

M.4 Other covariances

Before we obtain the remaining covariances for different degrees of kinship we compute the linear projections of $z_{t-1}^{G,a',n'}$, $z_{t-1}^{C,a',n'}$ and $y_{t-1}^{a',n'}$ on $z_{t-1}^{G,b,l}$, $z_{t-1}^{C,b,l}$ and $y_{t-1}^{b,l}$, $n', l = m, f$, where a' and b are siblings.

$$\begin{aligned}
z_{t-1}^{G,a',n'} &= r_{zGzG}^{n',l} z_{t-1}^{G,b,l} + r_{zGzC}^{n',l} z_{t-1}^{C,b,l} + r_{zGy}^{n',l} y_{t-1}^{b,l} + w_{t-1}^{G,n',l} \\
z_{t-1}^{C,a',n'} &= r_{zCzG}^{n',l} z_{t-1}^{G,b,l} + r_{zCzC}^{n',l} z_{t-1}^{C,b,l} + r_{zCy}^{n',l} y_{t-1}^{b,l} + w_{t-1}^{C,n',l} \\
y_{t-1}^{a',n'} &= r_{yzG}^{n',l} z_{t-1}^{G,b,l} + r_{yzC}^{n',l} z_{t-1}^{C,b,l} + r_{yy}^{n',l} y_{t-1}^{b,l} + \varepsilon_{t-1}^{n',l}
\end{aligned}$$

where $w_{t-1}^{G,n',l}$, $w_{t-1}^{C,n',l}$ and $\varepsilon_{t-1}^{n',l}$ might be correlated but are uncorrelated with $z_{t-1}^{G,b,l}$, $z_{t-1}^{C,b,l}$ and $y_{t-1}^{b,l}$. We have that

$$\begin{pmatrix} r_{zGzG}^{n',l} & r_{zGzC}^{n',l} & r_{zGy}^{n',l} \\ r_{zCzG}^{n',l} & r_{zCzC}^{n',l} & r_{zCy}^{n',l} \\ r_{yzG}^{n',l} & r_{yzC}^{n',l} & r_{yy}^{n',l} \end{pmatrix}' = \begin{pmatrix} \sigma_{zG,l}^2 & \sigma_{zG,lzC,l} & \sigma_{zG,l y^l} \\ \sigma_{zG,lzC,l} & \sigma_{zC,l}^2 & \sigma_{zC,l y^l} \\ \sigma_{zG,l y^l} & \sigma_{zC,l y^l} & \sigma_{y^l}^2 \end{pmatrix}^{-1} \begin{pmatrix} \sigma_{zG,b,lzG,a',n'} & \sigma_{zG,b,lzC,a',n'} & \sigma_{zG,b,l y^{a',n'}} \\ \sigma_{zC,b,lzG,a',n'} & \sigma_{zC,b,lzC,a',n'} & \sigma_{zC,b,l y^{a',n'}} \\ \sigma_{y^{b,l}zG,a',n'} & \sigma_{y^{b,l}zC,a',n'} & \sigma_{y^{b,l} y^{a',n'}} \end{pmatrix}$$

Consanguine relatives ("blood")

Vertical covariances

Uncle/aunt (siblings of the parents) $aa - b$

We have to compute the covariances between "aa" and "b". Let $n^* = m, f$ be the gender of aa and $l = m, f$ the gender of b . We project aa on a' (his/her father or mother) who has gender n'

$$\begin{aligned}
Cov(z_t^{G,aa,n^*}, z_{t-1}^{G,b,l}) &= Cov(G_{zgn'}^{n^*} z_{t-1}^{G,a',n'} + G_{zn'}^{n^*} z_{t-1}^{C,a',n'} + G_{yn'}^{n^*} y_{t-1}^{a',n'}, z_{t-1}^{G,b,l}) = \\
&G_{zgn'}^{n^*} Cov(z_{t-1}^{G,a',n'}, z_{t-1}^{G,b,l}) + G_{zn'}^{n^*} Cov(z_{t-1}^{C,a',n'}, z_{t-1}^{G,b,l}) + G_{yn'}^{n^*} Cov(y_{t-1}^{a',n'}, z_{t-1}^{G,b,l})
\end{aligned}$$

$$\begin{aligned}
Cov(z_t^{G,aa,n^*}, z_{t-1}^{C,b,l}) &= Cov(G_{zgn'}^{n^*} z_{t-1}^{G,a',n'} + G_{zn'}^{n^*} z_{t-1}^{C,a',n'} + G_{yn'}^{n^*} y_{t-1}^{a',n'}, z_{t-1}^{C,b,l}) = \\
&G_{zgn'}^{n^*} Cov(z_{t-1}^{G,a',n'}, z_{t-1}^{C,b,l}) + G_{zn'}^{n^*} Cov(z_{t-1}^{C,a',n'}, z_{t-1}^{C,b,l}) + G_{yn'}^{n^*} Cov(y_{t-1}^{a',n'}, z_{t-1}^{C,b,l})
\end{aligned}$$

$$Cov(z_t^{G,aa,n^*}, y_{t-1}^{b,l}) = Cov(G_{zgn'}^{n^*} z_{t-1}^{G,a',n'} + G_{zn'}^{n^*} z_{t-1}^{C,a',n'} + G_{yn'}^{n^*} y_{t-1}^{a',n'}, y_{t-1}^{b,l}) =$$

$$\begin{aligned}
& G_{zgn'}^{m*} Cov(z_{t-1}^{G,a',n'}, y_{t-1}^{b,l}) + G_{zn'}^{m*} Cov(z_{t-1}^{C,a',n'}, y_{t-1}^{b,l}) + G_{yn'}^{m*} Cov(y_{t-1}^{a',n'}, y_{t-1}^{b,l}) \\
Cov(z_t^{C,aa,n*}, z_{t-1}^{G,b,l}) &= Cov(C_{zgn'}^{m*} z_{t-1}^{G,a',n'} + C_{zn'}^{m*} z_{t-1}^{C,a',n'} + C_{yn'}^{m*} y_{t-1}^{a',n'}, z_{t-1}^{G,b,l}) = \\
& C_{zgn'}^{m*} Cov(z_{t-1}^{G,a',n'}, z_{t-1}^{G,b,l}) + C_{zn'}^{m*} Cov(z_{t-1}^{C,a',n'}, z_{t-1}^{G,b,l}) + C_{yn'}^{m*} Cov(y_{t-1}^{a',n'}, z_{t-1}^{G,b,l}) \\
Cov(z_t^{C,aa,n*}, z_{t-1}^{C,b,l}) &= Cov(C_{zgn'}^{m*} z_{t-1}^{G,a',n'} + C_{zn'}^{m*} z_{t-1}^{C,a',n'} + C_{yn'}^{m*} y_{t-1}^{a',n'}, z_{t-1}^{C,b,l}) = \\
& C_{zgn'}^{m*} Cov(z_{t-1}^{G,a',n'}, z_{t-1}^{C,b,l}) + C_{zn'}^{m*} Cov(z_{t-1}^{C,a',n'}, z_{t-1}^{C,b,l}) + C_{yn'}^{m*} Cov(y_{t-1}^{a',n'}, z_{t-1}^{C,b,l}) \\
Cov(z_t^{C,aa,n*}, y_{t-1}^{b,l}) &= Cov(C_{zgn'}^{m*} z_{t-1}^{G,a',n'} + C_{zn'}^{m*} z_{t-1}^{C,a',n'} + C_{yn'}^{m*} y_{t-1}^{a',n'}, y_{t-1}^{b,l}) = \\
& C_{zgn'}^{m*} Cov(z_{t-1}^{G,a',n'}, y_{t-1}^{b,l}) + C_{zn'}^{m*} Cov(z_{t-1}^{C,a',n'}, y_{t-1}^{b,l}) + C_{yn'}^{m*} Cov(y_{t-1}^{a',n'}, y_{t-1}^{b,l}) \\
Cov(y_t^{aa,n*}, z_{t-1}^{G,b,l}) &= Cov(B_{zgn'}^{n*} z_{t-1}^{G,a',n'} + B_{zn'}^{n*} z_{t-1}^{C,a',n'} + B_{yn'}^{n*} y_{t-1}^{a',n'}, z_{t-1}^{G,b,l}) = \\
& B_{zgn'}^{n*} Cov(z_{t-1}^{G,a',n'}, z_{t-1}^{G,b,l}) + B_{zn'}^{n*} Cov(z_{t-1}^{C,a',n'}, z_{t-1}^{G,b,l}) + B_{yn'}^{n*} Cov(y_{t-1}^{a',n'}, z_{t-1}^{G,b,l}) \\
Cov(y_t^{aa,n*}, z_{t-1}^{C,b,l}) &= Cov(B_{zgn'}^{n*} z_{t-1}^{G,a',n'} + B_{zn'}^{n*} z_{t-1}^{C,a',n'} + B_{yn'}^{n*} y_{t-1}^{a',n'}, z_{t-1}^{C,b,l}) = \\
& B_{zgn'}^{n*} Cov(z_{t-1}^{G,a',n'}, z_{t-1}^{C,b,l}) + B_{zn'}^{n*} Cov(z_{t-1}^{C,a',n'}, z_{t-1}^{C,b,l}) + B_{yn'}^{n*} Cov(y_{t-1}^{a',n'}, z_{t-1}^{C,b,l}) \\
Cov(y_t^{aa,n*}, y_{t-1}^{b,l}) &= Cov(B_{zgn'}^{n*} z_{t-1}^{G,a',n'} + B_{zn'}^{n*} z_{t-1}^{C,a',n'} + B_{yn'}^{n*} y_{t-1}^{a',n'}, y_{t-1}^{b,l}) = \\
& B_{zgn'}^{n*} Cov(z_{t-1}^{G,a',n'}, y_{t-1}^{b,l}) + B_{zn'}^{n*} Cov(z_{t-1}^{C,a',n'}, y_{t-1}^{b,l}) + B_{yn'}^{n*} Cov(y_{t-1}^{a',n'}, y_{t-1}^{b,l})
\end{aligned}$$

where a' and b are siblings.

Horizontal covariances

Cousins $aa - bb$

We have to compute the covariances between " aa " and " bb ". Let $n^* = m, f$ be the gender of aa and $l^* = m, f$ the gender of the bb . We project bb on b (his/her father or mother) who has gender l

$$\begin{aligned}
Cov(z_t^{G,aa,n*}, z_t^{G,bb,l^*}) &= Cov(z_t^{G,aa,n*}, G_{zgl}^{l*} z_{t-1}^{G,b,l} + G_{zl}^{l*} z_{t-1}^{C,b,l} + G_{yl}^{l*} y_{t-1}^{b,l}) \\
&= G_{zgl}^{l*} Cov(z_t^{G,aa,n*}, z_{t-1}^{G,b,l}) + G_{zl}^{l*} Cov(z_t^{G,aa,n*}, z_{t-1}^{C,b,l}) + G_{yl}^{l*} Cov(z_t^{G,aa,n*}, y_{t-1}^{b,l}) \\
Cov(z_t^{G,aa,n*}, z_t^{C,bb,l^*}) &= Cov(z_t^{G,aa,n*}, C_{zgl}^{l*} z_{t-1}^{G,b,l} + C_{zl}^{l*} z_{t-1}^{C,b,l} + C_{yl}^{l*} y_{t-1}^{b,l}) \\
&= C_{zgl}^{l*} Cov(z_t^{G,aa,n*}, z_{t-1}^{G,b,l}) + C_{zl}^{l*} Cov(z_t^{G,aa,n*}, z_{t-1}^{C,b,l}) + C_{yl}^{l*} Cov(z_t^{G,aa,n*}, y_{t-1}^{b,l})
\end{aligned}$$

$$\begin{aligned}
Cov(z_t^{G,aa,n^*}, y_t^{bb,l^*}) &= Cov(z_t^{G,aa,n^*}, B_{zgl}^{l^*} z_{t-1}^{G,b,l} + B_{zl}^{l^*} z_{t-1}^{C,b,l} + B_{yl}^{l^*} y_{t-1}^{b,l}) \\
&= B_{zgl}^{l^*} Cov(z_t^{G,aa,n^*}, z_{t-1}^{G,b,l}) + B_{zl}^{l^*} Cov(z_t^{G,aa,n^*}, z_{t-1}^{C,b,l}) + B_{yl}^{l^*} Cov(z_t^{G,aa,n^*}, y_{t-1}^{b,l})
\end{aligned}$$

$$\begin{aligned}
Cov(z_t^{C,aa,n^*}, z_t^{G,bb,l^*}) &= Cov(z_t^{C,aa,n^*}, G_{zgl}^{l^*} z_{t-1}^{G,b,l} + G_{zl}^{l^*} z_{t-1}^{C,b,l} + G_{yl}^{l^*} y_{t-1}^{b,l}) \\
&= G_{zgl}^{l^*} Cov(z_t^{C,aa,n^*}, z_{t-1}^{G,b,l}) + G_{zl}^{l^*} Cov(z_t^{C,aa,n^*}, z_{t-1}^{C,b,l}) + G_{yl}^{l^*} Cov(z_t^{C,aa,n^*}, y_{t-1}^{b,l})
\end{aligned}$$

$$\begin{aligned}
Cov(z_t^{C,aa,n^*}, z_t^{C,bb,l^*}) &= Cov(z_t^{C,aa,n^*}, C_{zgl}^{l^*} z_{t-1}^{G,b,l} + C_{zl}^{l^*} z_{t-1}^{C,b,l} + C_{yl}^{l^*} y_{t-1}^{b,l}) \\
&= C_{zgl}^{l^*} Cov(z_t^{C,aa,n^*}, z_{t-1}^{G,b,l}) + C_{zl}^{l^*} Cov(z_t^{C,aa,n^*}, z_{t-1}^{C,b,l}) + C_{yl}^{l^*} Cov(z_t^{C,aa,n^*}, y_{t-1}^{b,l})
\end{aligned}$$

$$\begin{aligned}
Cov(z_t^{C,aa,n^*}, y_t^{bb,l^*}) &= Cov(z_t^{C,aa,n^*}, B_{zgl}^{l^*} z_{t-1}^{G,b,l} + B_{zl}^{l^*} z_{t-1}^{C,b,l} + B_{yl}^{l^*} y_{t-1}^{b,l}) \\
&= B_{zgl}^{l^*} Cov(z_t^{C,aa,n^*}, z_{t-1}^{G,b,l}) + B_{zl}^{l^*} Cov(z_t^{C,aa,n^*}, z_{t-1}^{C,b,l}) + B_{yl}^{l^*} Cov(z_t^{C,aa,n^*}, y_{t-1}^{b,l})
\end{aligned}$$

$$\begin{aligned}
Cov(y_t^{aa,n^*}, z_t^{G,bb,l^*}) &= Cov(y_t^{aa,n^*}, G_{zgl}^{l^*} z_{t-1}^{G,b,l} + G_{zl}^{l^*} z_{t-1}^{C,b,l} + G_{yl}^{l^*} y_{t-1}^{b,l}) \\
&= G_{zgl}^{l^*} Cov(y_t^{aa,n^*}, z_{t-1}^{G,b,l}) + G_{zl}^{l^*} Cov(y_t^{aa,n^*}, z_{t-1}^{C,b,l}) + G_{yl}^{l^*} Cov(y_t^{aa,n^*}, y_{t-1}^{b,l})
\end{aligned}$$

$$\begin{aligned}
Cov(z_t^{G,aa,n^*}, z_t^{C,bb,l^*}) &= Cov(y_t^{aa,n^*}, C_{zgl}^{l^*} z_{t-1}^{G,b,l} + C_{zl}^{l^*} z_{t-1}^{C,b,l} + C_{yl}^{l^*} y_{t-1}^{b,l}) \\
&= C_{zgl}^{l^*} Cov(y_t^{aa,n^*}, z_{t-1}^{G,b,l}) + C_{zl}^{l^*} Cov(y_t^{aa,n^*}, z_{t-1}^{C,b,l}) + C_{yl}^{l^*} Cov(y_t^{aa,n^*}, y_{t-1}^{b,l})
\end{aligned}$$

$$\begin{aligned}
Cov(y_t^{aa,n^*}, y_t^{bb,l^*}) &= Cov(y_t^{aa,n^*}, B_{zgl}^{l^*} z_{t-1}^{G,b,l} + B_{zl}^{l^*} z_{t-1}^{C,b,l} + B_{yl}^{l^*} y_{t-1}^{b,l}) \\
&= B_{zgl}^{l^*} Cov(y_t^{aa,n^*}, z_{t-1}^{G,b,l}) + B_{zl}^{l^*} Cov(y_t^{aa,n^*}, z_{t-1}^{C,b,l}) + B_{yl}^{l^*} Cov(y_t^{aa,n^*}, y_{t-1}^{b,l})
\end{aligned}$$

where b is the uncle/aunt of aa .

Affinity relatives ("in-law")

Vertical covariances

Spouse of the uncle/aunt (spouses of the siblings of the parents) $aa - b'$

We have to compute the covariances between " aa " and " b' ". Let $n^* = m, f$ be the gender of aa and $l' = m, f$ the gender of the b' . We project b' on his/her spouse b

$$Cov(z_t^{G,aa,n^*}, z_{t-1}^{G,b',l'}) = Cov(z_t^{G,aa,n^*}, r_{zGzG}^l z_{t-1}^{G,b,l} + r_{zGzC}^l z_{t-1}^{C,b,l} + r_{zGy}^l y_{t-1}^{b,l})$$

$$= r_{z^l z^G z^G}^l Cov(z_t^{G,aa,n^*}, z_{t-1}^{G,b,l}) + r_{z^l z^G z^C}^l Cov(z_t^{G,aa,n^*}, z_{t-1}^{C,b,l}) + r_{z^l z^G y}^l Cov(z_t^{G,aa,n^*}, y_{t-1}^{b,l})$$

$$\begin{aligned} Cov(z_t^{G,aa,n^*}, z_{t-1}^{C,b',l'}) &= Cov(z_t^{G,aa,n^*}, r_{z^l z^G z^G}^l z_{t-1}^{G,b,l} + r_{z^l z^G z^C}^l z_{t-1}^{C,b,l} + r_{z^l z^G y}^l y_{t-1}^{b,l}) \\ &= r_{z^l z^G z^G}^l Cov(z_t^{G,aa,n^*}, z_{t-1}^{G,b,l}) + r_{z^l z^G z^C}^l Cov(z_t^{G,aa,n^*}, z_{t-1}^{C,b,l}) + r_{z^l z^G y}^l Cov(z_t^{G,aa,n^*}, y_{t-1}^{b,l}) \end{aligned}$$

$$\begin{aligned} Cov(z_t^{G,aa,n^*}, y_{t-1}^{b',l'}) &= Cov(z_t^{G,aa,n^*}, r_{y z^G}^l z_{t-1}^{G,b,l} + r_{y z^C}^l z_{t-1}^{C,b,l} + r_{y y}^l y_{t-1}^{b,l}) \\ &= r_{y z^G}^l Cov(z_t^{G,aa,n^*}, z_{t-1}^{G,b,l}) + r_{y z^C}^l Cov(z_t^{G,aa,n^*}, z_{t-1}^{C,b,l}) + r_{y y}^l Cov(z_t^{G,aa,n^*}, y_{t-1}^{b,l}) \end{aligned}$$

$$\begin{aligned} Cov(z_t^{C,aa,n^*}, z_{t-1}^{G,b',l'}) &= Cov(z_t^{C,aa,n^*}, r_{z^l z^G z^G}^l z_{t-1}^{G,b,l} + r_{z^l z^G z^C}^l z_{t-1}^{C,b,l} + r_{z^l z^G y}^l y_{t-1}^{b,l}) \\ &= r_{z^l z^G z^G}^l Cov(z_t^{C,aa,n^*}, z_{t-1}^{G,b,l}) + r_{z^l z^G z^C}^l Cov(z_t^{C,aa,n^*}, z_{t-1}^{C,b,l}) + r_{z^l z^G y}^l Cov(z_t^{C,aa,n^*}, y_{t-1}^{b,l}) \end{aligned}$$

$$\begin{aligned} Cov(z_t^{C,aa,n^*}, z_{t-1}^{C,b',l'}) &= Cov(z_t^{C,aa,n^*}, r_{z^l z^C z^G}^l z_{t-1}^{G,b,l} + r_{z^l z^C z^C}^l z_{t-1}^{C,b,l} + r_{z^l z^C y}^l y_{t-1}^{b,l}) \\ &= r_{z^l z^C z^G}^l Cov(z_t^{C,aa,n^*}, z_{t-1}^{G,b,l}) + r_{z^l z^C z^C}^l Cov(z_t^{C,aa,n^*}, z_{t-1}^{C,b,l}) + r_{z^l z^C y}^l Cov(z_t^{C,aa,n^*}, y_{t-1}^{b,l}) \end{aligned}$$

$$\begin{aligned} Cov(z_t^{C,aa,n^*}, y_{t-1}^{b',l'}) &= Cov(z_t^{C,aa,n^*}, r_{y z^G}^l z_{t-1}^{G,b,l} + r_{y z^C}^l z_{t-1}^{C,b,l} + r_{y y}^l y_{t-1}^{b,l}) \\ &= r_{y z^G}^l Cov(z_t^{C,aa,n^*}, z_{t-1}^{G,b,l}) + r_{y z^C}^l Cov(z_t^{C,aa,n^*}, z_{t-1}^{C,b,l}) + r_{y y}^l Cov(z_t^{C,aa,n^*}, y_{t-1}^{b,l}) \end{aligned}$$

$$\begin{aligned} Cov(y_t^{aa,n^*}, z_{t-1}^{G,b',l'}) &= Cov(y_t^{aa,n^*}, r_{z^l z^G z^G}^l z_{t-1}^{G,b,l} + r_{z^l z^G z^C}^l z_{t-1}^{C,b,l} + r_{z^l z^G y}^l y_{t-1}^{b,l}) \\ &= r_{z^l z^G z^G}^l Cov(y_t^{aa,n^*}, z_{t-1}^{G,b,l}) + r_{z^l z^G z^C}^l Cov(y_t^{aa,n^*}, z_{t-1}^{C,b,l}) + r_{z^l z^G y}^l Cov(y_t^{aa,n^*}, y_{t-1}^{b,l}) \end{aligned}$$

$$\begin{aligned} Cov(y_t^{aa,n^*}, z_{t-1}^{C,b',l'}) &= Cov(y_t^{aa,n^*}, r_{z^l z^C z^G}^l z_{t-1}^{G,b,l} + r_{z^l z^C z^C}^l z_{t-1}^{C,b,l} + r_{z^l z^C y}^l y_{t-1}^{b,l}) \\ &= r_{z^l z^C z^G}^l Cov(y_t^{aa,n^*}, z_{t-1}^{G,b,l}) + r_{z^l z^C z^C}^l Cov(y_t^{aa,n^*}, z_{t-1}^{C,b,l}) + r_{z^l z^C y}^l Cov(y_t^{aa,n^*}, y_{t-1}^{b,l}) \end{aligned}$$

$$\begin{aligned} Cov(y_t^{aa,n^*}, y_{t-1}^{b',l'}) &= Cov(y_t^{aa,n^*}, r_{y z^G}^l z_{t-1}^{G,b,l} + r_{y z^C}^l z_{t-1}^{C,b,l} + r_{y y}^l y_{t-1}^{b,l}) \\ &= r_{y z^G}^l Cov(y_t^{aa,n^*}, z_{t-1}^{G,b,l}) + r_{y z^C}^l Cov(y_t^{aa,n^*}, z_{t-1}^{C,b,l}) + r_{y y}^l Cov(y_t^{aa,n^*}, y_{t-1}^{b,l}) \end{aligned}$$

where b is uncle/aunt of aa .

Siblings of the siblings in law of the parents $aa - c$

We have to compute the covariances between " aa " and " c ". Let $n^* = m, f$ be the gender of aa and $o = m, f$

the gender of the c . We project c on his/her sibling b'

$$\begin{aligned} Cov(z_t^{G,aa,n^*}, z_{t-1}^{G,c,o}) &= Cov(z_t^{G,aa,n^*}, r_{zGzG}^{o,l'} z_{t-1}^{G,b',l'} + r_{zGzC}^{o,l'} z_{t-1}^{C,b',l'} + r_{zGy}^{o,l'} y_{t-1}^{b',l'}) \\ &= r_{zGzG}^{o,l'} Cov(z_t^{G,aa,n^*}, z_{t-1}^{G,b',l'}) + r_{zGzC}^{o,l'} Cov(z_t^{G,aa,n^*}, z_{t-1}^{C,b',l'}) + r_{zGy}^{o,l'} Cov(z_t^{G,aa,n^*}, y_{t-1}^{b',l'}) \end{aligned}$$

$$\begin{aligned} Cov(z_t^{G,aa,n^*}, z_{t-1}^{C,c,o}) &= Cov(z_t^{G,aa,n^*}, r_{zCzG}^{o,l'} z_{t-1}^{G,b',l'} + r_{zCzC}^{o,l'} z_{t-1}^{C,b',l'} + r_{zCy}^{o,l'} y_{t-1}^{b',l'}) \\ &= r_{zCzG}^{o,l'} Cov(z_t^{G,aa,n^*}, z_{t-1}^{G,b',l'}) + r_{zCzC}^{o,l'} Cov(z_t^{G,aa,n^*}, z_{t-1}^{C,b',l'}) + r_{zCy}^{o,l'} Cov(z_t^{G,aa,n^*}, y_{t-1}^{b',l'}) \end{aligned}$$

$$\begin{aligned} Cov(z_t^{G,aa,n^*}, y_{t-1}^{c,o}) &= Cov(z_t^{G,aa,n^*}, r_{yzG}^{o,l'} z_{t-1}^{G,b',l'} + r_{yzC}^{o,l'} z_{t-1}^{C,b',l'} + r_{yy}^{o,l'} y_{t-1}^{b',l'}) \\ &= r_{yzG}^{o,l'} Cov(z_t^{G,aa,n^*}, z_{t-1}^{G,b',l'}) + r_{yzC}^{o,l'} Cov(z_t^{G,aa,n^*}, z_{t-1}^{C,b',l'}) + r_{yy}^{o,l'} Cov(z_t^{G,aa,n^*}, y_{t-1}^{b',l'}) \end{aligned}$$

$$\begin{aligned} Cov(z_t^{C,aa,n^*}, z_{t-1}^{G,c,o}) &= Cov(z_t^{C,aa,n^*}, r_{zGzG}^{o,l'} z_{t-1}^{G,b',l'} + r_{zGzC}^{o,l'} z_{t-1}^{C,b',l'} + r_{zGy}^{o,l'} y_{t-1}^{b',l'}) \\ &= r_{zGzG}^{o,l'} Cov(z_t^{C,aa,n^*}, z_{t-1}^{G,b',l'}) + r_{zGzC}^{o,l'} Cov(z_t^{C,aa,n^*}, z_{t-1}^{C,b',l'}) + r_{zGy}^{o,l'} Cov(z_t^{C,aa,n^*}, y_{t-1}^{b',l'}) \end{aligned}$$

$$\begin{aligned} Cov(z_t^{C,aa,n^*}, z_{t-1}^{C,c,o}) &= Cov(z_t^{C,aa,n^*}, r_{zCzG}^{o,l'} z_{t-1}^{G,b',l'} + r_{zCzC}^{o,l'} z_{t-1}^{C,b',l'} + r_{zCy}^{o,l'} y_{t-1}^{b',l'}) \\ &= r_{zCzG}^{o,l'} Cov(z_t^{C,aa,n^*}, z_{t-1}^{G,b',l'}) + r_{zCzC}^{o,l'} Cov(z_t^{C,aa,n^*}, z_{t-1}^{C,b',l'}) + r_{zCy}^{o,l'} Cov(z_t^{C,aa,n^*}, y_{t-1}^{b',l'}) \end{aligned}$$

$$\begin{aligned} Cov(z_t^{C,aa,n^*}, y_{t-1}^{c,o}) &= Cov(z_t^{C,aa,n^*}, r_{yzG}^{o,l'} z_{t-1}^{G,b',l'} + r_{yzC}^{o,l'} z_{t-1}^{C,b',l'} + r_{yy}^{o,l'} y_{t-1}^{b',l'}) \\ &= r_{yzG}^{o,l'} Cov(z_t^{C,aa,n^*}, z_{t-1}^{G,b',l'}) + r_{yzC}^{o,l'} Cov(z_t^{C,aa,n^*}, z_{t-1}^{C,b',l'}) + r_{yy}^{o,l'} Cov(z_t^{C,aa,n^*}, y_{t-1}^{b',l'}) \end{aligned}$$

$$\begin{aligned} Cov(y_t^{aa,n^*}, z_{t-1}^{G,c,o}) &= Cov(y_t^{aa,n^*}, r_{zGzG}^{o,l'} z_{t-1}^{G,b',l'} + r_{zGzC}^{o,l'} z_{t-1}^{C,b',l'} + r_{zGy}^{o,l'} y_{t-1}^{b',l'}) \\ &= r_{zGzG}^{o,l'} Cov(y_t^{aa,n^*}, z_{t-1}^{G,b',l'}) + r_{zGzC}^{o,l'} Cov(y_t^{aa,n^*}, z_{t-1}^{C,b',l'}) + r_{zGy}^{o,l'} Cov(y_t^{aa,n^*}, y_{t-1}^{b',l'}) \end{aligned}$$

$$\begin{aligned} Cov(y_t^{aa,n^*}, z_{t-1}^{C,c,o}) &= Cov(y_t^{aa,n^*}, r_{zCzG}^{o,l'} z_{t-1}^{G,b',l'} + r_{zCzC}^{o,l'} z_{t-1}^{C,b',l'} + r_{zCy}^{o,l'} y_{t-1}^{b',l'}) \\ &= r_{zCzG}^{o,l'} Cov(y_t^{aa,n^*}, z_{t-1}^{G,b',l'}) + r_{zCzC}^{o,l'} Cov(y_t^{aa,n^*}, z_{t-1}^{C,b',l'}) + r_{zCy}^{o,l'} Cov(y_t^{aa,n^*}, y_{t-1}^{b',l'}) \end{aligned}$$

$$\begin{aligned} Cov(y_t^{aa,n^*}, y_{t-1}^{c,o}) &= Cov(y_t^{aa,n^*}, r_{yzG}^{o,l'} z_{t-1}^{G,b',l'} + r_{yzC}^{o,l'} z_{t-1}^{C,b',l'} + r_{yy}^{o,l'} y_{t-1}^{b',l'}) \\ &= r_{yzG}^{o,l'} Cov(y_t^{aa,n^*}, z_{t-1}^{G,b',l'}) + r_{yzC}^{o,l'} Cov(y_t^{aa,n^*}, z_{t-1}^{C,b',l'}) + r_{yy}^{o,l'} Cov(y_t^{aa,n^*}, y_{t-1}^{b',l'}) \end{aligned}$$

where y is the spouse of the uncle/aunt of aa .

We can recursively compute the covariance for spouses of the siblings in law of the parents and siblings of

the siblings in law of the parents of any degree.

Horizontal covariances

Siblings in law $a - b$

We have to compute the covariances between "a" and "b". Let $n = m, f$ be the gender of a and $l = m, f$ the gender of the b . We project a on his/her spouse a' with gender $n' = f, m$

$$\begin{aligned} Cov(z_{t-1}^{G,a,n}, z_{t-1}^{G,b,l}) &= Cov(r_{z^G z^G}^{n'} z_{t-1}^{G,a',n'} + r_{z^G z^C}^{n'} z_{t-1}^{C,a',n'} + r_{z^G y}^{n'} y_{t-1}^{a',n'}, z_{t-1}^{G,b,l}) \\ &= r_{z^G z^G}^{n'} Cov(z_{t-1}^{G,a',n'}, z_{t-1}^{G,b,l}) + r_{z^G z^C}^{n'} Cov(z_{t-1}^{C,a',n'}, z_{t-1}^{G,b,l}) + r_{z^G y}^{n'} Cov(y_{t-1}^{a',n'}, z_{t-1}^{G,b,l}) \end{aligned}$$

$$\begin{aligned} Cov(z_{t-1}^{G,a,n}, z_{t-1}^{C,b,l}) &= Cov(r_{z^G z^G}^{n'} z_{t-1}^{G,a',n'} + r_{z^G z^C}^{n'} z_{t-1}^{C,a',n'} + r_{z^G y}^{n'} y_{t-1}^{a',n'}, z_{t-1}^{C,b,l}) \\ &= r_{z^G z^G}^{n'} Cov(z_{t-1}^{G,a',n'}, z_{t-1}^{C,b,l}) + r_{z^G z^C}^{n'} Cov(z_{t-1}^{C,a',n'}, z_{t-1}^{C,b,l}) + r_{z^G y}^{n'} Cov(y_{t-1}^{a',n'}, z_{t-1}^{C,b,l}) \end{aligned}$$

$$\begin{aligned} Cov(z_{t-1}^{G,a,n}, y_{t-1}^{b,l}) &= Cov(r_{z^G z^G}^{n'} z_{t-1}^{G,a',n'} + r_{z^G z^C}^{n'} z_{t-1}^{C,a',n'} + r_{z^G y}^{n'} y_{t-1}^{a',n'}, y_{t-1}^{b,l}) \\ &= r_{z^G z^G}^{n'} Cov(z_{t-1}^{G,a',n'}, y_{t-1}^{b,l}) + r_{z^G z^C}^{n'} Cov(z_{t-1}^{C,a',n'}, y_{t-1}^{b,l}) + r_{z^G y}^{n'} Cov(y_{t-1}^{a',n'}, y_{t-1}^{b,l}) \end{aligned}$$

$$\begin{aligned} Cov(z_{t-1}^{C,a,n}, z_{t-1}^{G,b,l}) &= Cov(r_{z^C z^G}^{n'} z_{t-1}^{G,a',n'} + r_{z^C z^C}^{n'} z_{t-1}^{C,a',n'} + r_{z^C y}^{n'} y_{t-1}^{a',n'}, z_{t-1}^{G,b,l}) \\ &= r_{z^C z^G}^{n'} Cov(z_{t-1}^{G,a',n'}, z_{t-1}^{G,b,l}) + r_{z^C z^C}^{n'} Cov(z_{t-1}^{C,a',n'}, z_{t-1}^{G,b,l}) + r_{z^C y}^{n'} Cov(y_{t-1}^{a',n'}, z_{t-1}^{G,b,l}) \end{aligned}$$

$$\begin{aligned} Cov(z_{t-1}^{C,a,n}, z_{t-1}^{C,b,l}) &= Cov(r_{z^C z^G}^{n'} z_{t-1}^{G,a',n'} + r_{z^C z^C}^{n'} z_{t-1}^{C,a',n'} + r_{z^C y}^{n'} y_{t-1}^{a',n'}, z_{t-1}^{C,b,l}) \\ &= r_{z^C z^G}^{n'} Cov(z_{t-1}^{G,a',n'}, z_{t-1}^{C,b,l}) + r_{z^C z^C}^{n'} Cov(z_{t-1}^{C,a',n'}, z_{t-1}^{C,b,l}) + r_{z^C y}^{n'} Cov(y_{t-1}^{a',n'}, z_{t-1}^{C,b,l}) \end{aligned}$$

$$\begin{aligned} Cov(z_{t-1}^{C,a,n}, y_{t-1}^{b,l}) &= Cov(r_{z^C z^G}^{n'} z_{t-1}^{G,a',n'} + r_{z^C z^C}^{n'} z_{t-1}^{C,a',n'} + r_{z^C y}^{n'} y_{t-1}^{a',n'}, y_{t-1}^{b,l}) \\ &= r_{z^C z^G}^{n'} Cov(z_{t-1}^{G,a',n'}, y_{t-1}^{b,l}) + r_{z^C z^C}^{n'} Cov(z_{t-1}^{C,a',n'}, y_{t-1}^{b,l}) + r_{z^C y}^{n'} Cov(y_{t-1}^{a',n'}, y_{t-1}^{b,l}) \end{aligned}$$

$$\begin{aligned} Cov(y_{t-1}^{a,n}, z_{t-1}^{G,b,l}) &= Cov(r_{y z^G}^{n'} z_{t-1}^{G,a',n'} + r_{y z^C}^{n'} z_{t-1}^{C,a',n'} + r_{y y}^{n'} y_{t-1}^{a',n'}, z_{t-1}^{G,b,l}) \\ &= r_{y z^G}^{n'} Cov(z_{t-1}^{G,a',n'}, z_{t-1}^{G,b,l}) + r_{y z^C}^{n'} Cov(z_{t-1}^{C,a',n'}, z_{t-1}^{G,b,l}) + r_{y y}^{n'} Cov(y_{t-1}^{a',n'}, z_{t-1}^{G,b,l}) \end{aligned}$$

$$\begin{aligned} Cov(y_{t-1}^{a,n}, z_{t-1}^{C,b,l}) &= Cov(r_{y z^G}^{n'} z_{t-1}^{G,a',n'} + r_{y z^C}^{n'} z_{t-1}^{C,a',n'} + r_{y y}^{n'} y_{t-1}^{a',n'}, z_{t-1}^{C,b,l}) \\ &= r_{y z^G}^{n'} Cov(z_{t-1}^{G,a',n'}, z_{t-1}^{C,b,l}) + r_{y z^C}^{n'} Cov(z_{t-1}^{C,a',n'}, z_{t-1}^{C,b,l}) + r_{y y}^{n'} Cov(y_{t-1}^{a',n'}, z_{t-1}^{C,b,l}) \end{aligned}$$

$$\begin{aligned}
Cov(y_{t-1}^{a,n}, y_{t-1}^{b,l}) &= Cov(r_{yz^G}^{n'} z_{t-1}^{G,a',n'} + r_{yz^C}^{n'} z_{t-1}^{C,a',n'} + r_{yy}^{n'} y_{t-1}^{a',n'}, y_{t-1}^{b,l}) \\
&= r_{yz^G}^{n'} Cov(z_{t-1}^{G,a',n'}, y_{t-1}^{b,l}) + r_{yz^C}^{n'} Cov(z_{t-1}^{C,a',n'}, y_{t-1}^{b,l}) + r_{yy}^{n'} Cov(y_{t-1}^{a',n'}, y_{t-1}^{b,l})
\end{aligned}$$

where a' and b are siblings.

Spouse of the siblings in law $a - b'$

We have to compute the covariances between " a " and " b' ". Let $n = m, f$ be the gender of a and $l' = m, f$ the gender of the b' . We project b' on his/her spouse b

$$\begin{aligned}
Cov(z_t^{G,a,n}, z_{t-1}^{G,b',l'}) &= Cov(z_t^{G,a,n}, r_{z^G z^G}^l z_{t-1}^{G,b,l} + r_{z^G z^C}^l z_{t-1}^{C,b,l} + r_{z^G y}^l y_{t-1}^{b,l}) \\
&= r_{z^G z^G}^l Cov(z_t^{G,a,n}, z_{t-1}^{G,b,l}) + r_{z^G z^C}^l Cov(z_t^{G,a,n}, z_{t-1}^{C,b,l}) + r_{z^G y}^l Cov(z_t^{G,a,n}, y_{t-1}^{b,l})
\end{aligned}$$

$$\begin{aligned}
Cov(z_t^{G,a,n}, z_{t-1}^{C,b',l'}) &= Cov(z_t^{G,a,n}, r_{z^C z^G}^l z_{t-1}^{G,b,l} + r_{z^C z^C}^l z_{t-1}^{C,b,l} + r_{z^C y}^l y_{t-1}^{b,l}) \\
&= r_{z^C z^G}^l Cov(z_t^{G,a,n}, z_{t-1}^{G,b,l}) + r_{z^C z^C}^l Cov(z_t^{G,a,n}, z_{t-1}^{C,b,l}) + r_{z^C y}^l Cov(z_t^{G,a,n}, y_{t-1}^{b,l})
\end{aligned}$$

$$\begin{aligned}
Cov(z_t^{G,a,n}, y_{t-1}^{b',l'}) &= Cov(z_t^{G,a,n}, r_{yz^G}^l z_{t-1}^{G,b,l} + r_{yz^C}^l z_{t-1}^{C,b,l} + r_{yy}^l y_{t-1}^{b,l}) \\
&= r_{yz^G}^l Cov(z_t^{G,a,n}, z_{t-1}^{G,b,l}) + r_{yz^C}^l Cov(z_t^{G,a,n}, z_{t-1}^{C,b,l}) + r_{yy}^l Cov(z_t^{G,a,n}, y_{t-1}^{b,l})
\end{aligned}$$

$$\begin{aligned}
Cov(z_t^{C,a,n}, z_{t-1}^{G,b',l'}) &= Cov(z_t^{C,a,n}, r_{z^G z^G}^l z_{t-1}^{G,b,l} + r_{z^G z^C}^l z_{t-1}^{C,b,l} + r_{z^G y}^l y_{t-1}^{b,l}) \\
&= r_{z^G z^G}^l Cov(z_t^{C,a,n}, z_{t-1}^{G,b,l}) + r_{z^G z^C}^l Cov(z_t^{C,a,n}, z_{t-1}^{C,b,l}) + r_{z^G y}^l Cov(z_t^{C,a,n}, y_{t-1}^{b,l})
\end{aligned}$$

$$\begin{aligned}
Cov(z_t^{C,a,n}, z_{t-1}^{C,b',l'}) &= Cov(z_t^{C,a,n}, r_{z^C z^G}^l z_{t-1}^{G,b,l} + r_{z^C z^C}^l z_{t-1}^{C,b,l} + r_{z^C y}^l y_{t-1}^{b,l}) \\
&= r_{z^C z^G}^l Cov(z_t^{C,a,n}, z_{t-1}^{G,b,l}) + r_{z^C z^C}^l Cov(z_t^{C,a,n}, z_{t-1}^{C,b,l}) + r_{z^C y}^l Cov(z_t^{C,a,n}, y_{t-1}^{b,l})
\end{aligned}$$

$$\begin{aligned}
Cov(z_t^{C,a,n}, y_{t-1}^{b',l'}) &= Cov(z_t^{C,a,n}, r_{yz^G}^l z_{t-1}^{G,b,l} + r_{yz^C}^l z_{t-1}^{C,b,l} + r_{yy}^l y_{t-1}^{b,l}) \\
&= r_{yz^G}^l Cov(z_t^{C,a,n}, z_{t-1}^{G,b,l}) + r_{yz^C}^l Cov(z_t^{C,a,n}, z_{t-1}^{C,b,l}) + r_{yy}^l Cov(z_t^{C,a,n}, y_{t-1}^{b,l})
\end{aligned}$$

$$\begin{aligned}
Cov(y_t^{a,n}, z_{t-1}^{G,b',l'}) &= Cov(y_t^{a,n}, r_{z^G z^G}^l z_{t-1}^{G,b,l} + r_{z^G z^C}^l z_{t-1}^{C,b,l} + r_{z^G y}^l y_{t-1}^{b,l}) \\
&= r_{z^G z^G}^l Cov(y_t^{a,n}, z_{t-1}^{G,b,l}) + r_{z^G z^C}^l Cov(y_t^{a,n}, z_{t-1}^{C,b,l}) + r_{z^G y}^l Cov(y_t^{a,n}, y_{t-1}^{b,l})
\end{aligned}$$

$$Cov(y_t^{a,n}, z_{t-1}^{C,b',l'}) = Cov(y_t^{a,n}, r_{z^C z^G}^l z_{t-1}^{G,b,l} + r_{z^C z^C}^l z_{t-1}^{C,b,l} + r_{z^C y}^l y_{t-1}^{b,l})$$

$$= r_{z^l c z^G}^l Cov(y_t^{a,n}, z_{t-1}^{G,b,l}) + r_{z^l c z^C}^l Cov(y_t^{a,n}, z_{t-1}^{C,b,l}) + r_{z^l c y}^l Cov(y_t^{a,n}, y_{t-1}^{b,l})$$

$$\begin{aligned} Cov(y_t^{a,n}, y_{t-1}^{b,l'}) &= Cov(y_t^{a,n}, r_{yz^G}^l z_{t-1}^{G,b,l} + r_{yz^C}^l z_{t-1}^{C,b,l} + r_{yy}^l y_{t-1}^{b,l}) \\ &= r_{yz^G}^l Cov(y_t^{a,n}, z_{t-1}^{G,b,l}) + r_{yz^C}^l Cov(y_t^{a,n}, z_{t-1}^{C,b,l}) + r_{yy}^l Cov(y_t^{a,n}, y_{t-1}^{b,l}) \end{aligned}$$

where a and b are siblings in law.

Sibling of the sibling in law $a' - c$

We have to compute the covariances between " a' " and " c ". Let $n' = m, f$ be the gender of a' and $o = m, f$ the gender of the c . We project a' on his/her sibling b who has gender l

$$\begin{aligned} Cov(z_{t-1}^{G,a',n'}, z_{t-1}^{G,c,o}) &= Cov(r_{z^G z^G}^{n',l} z_{t-1}^{G,b,l} + r_{z^G z^C}^{n',l} z_{t-1}^{C,b,l} + r_{z^G y}^{n',l} y_{t-1}^{b,l}, z_{t-1}^{G,c,o}) \\ &= r_{z^G z^G}^{n',l} Cov(z_{t-1}^{G,b,l}, z_{t-1}^{G,c,o}) + r_{z^G z^C}^{n',l} Cov(z_{t-1}^{C,b,l}, z_{t-1}^{G,c,o}) + r_{z^G y}^{n',l} Cov(y_{t-1}^{b,l}, z_{t-1}^{G,c,o}) \end{aligned}$$

$$\begin{aligned} Cov(z_{t-1}^{G,a',n'}, z_{t-1}^{C,c,o}) &= Cov(r_{z^G z^G}^{n',l} z_{t-1}^{G,b,l} + r_{z^G z^C}^{n',l} z_{t-1}^{C,b,l} + r_{z^G y}^{n',l} y_{t-1}^{b,l}, z_{t-1}^{C,c,o}) \\ &= r_{z^G z^G}^{n',l} Cov(z_{t-1}^{G,b,l}, z_{t-1}^{C,c,o}) + r_{z^G z^C}^{n',l} Cov(z_{t-1}^{C,b,l}, z_{t-1}^{C,c,o}) + r_{z^G y}^{n',l} Cov(y_{t-1}^{b,l}, z_{t-1}^{C,c,o}) \end{aligned}$$

$$\begin{aligned} Cov(z_{t-1}^{G,a',n'}, y_{t-1}^{c,o}) &= Cov(r_{z^G z^G}^{n',l} z_{t-1}^{G,b,l} + r_{z^G z^C}^{n',l} z_{t-1}^{C,b,l} + r_{z^G y}^{n',l} y_{t-1}^{b,l}, y_{t-1}^{c,o}) \\ &= r_{z^G z^G}^{n',l} Cov(z_{t-1}^{G,b,l}, y_{t-1}^{c,o}) + r_{z^G z^C}^{n',l} Cov(z_{t-1}^{C,b,l}, y_{t-1}^{c,o}) + r_{z^G y}^{n',l} Cov(y_{t-1}^{b,l}, y_{t-1}^{c,o}) \end{aligned}$$

$$\begin{aligned} Cov(z_{t-1}^{C,a',n'}, z_{t-1}^{G,c,o}) &= Cov(r_{z^C z^G}^{n',l} z_{t-1}^{G,b,l} + r_{z^C z^C}^{n',l} z_{t-1}^{C,b,l} + r_{z^C y}^{n',l} y_{t-1}^{b,l}, z_{t-1}^{G,c,o}) \\ &= r_{z^C z^G}^{n',l} Cov(z_{t-1}^{G,b,l}, z_{t-1}^{G,c,o}) + r_{z^C z^C}^{n',l} Cov(z_{t-1}^{C,b,l}, z_{t-1}^{G,c,o}) + r_{z^C y}^{n',l} Cov(y_{t-1}^{b,l}, z_{t-1}^{G,c,o}) \end{aligned}$$

$$\begin{aligned} Cov(z_{t-1}^{C,a',n'}, z_{t-1}^{C,c,o}) &= Cov(r_{z^C z^G}^{n',l} z_{t-1}^{G,b,l} + r_{z^C z^C}^{n',l} z_{t-1}^{C,b,l} + r_{z^C y}^{n',l} y_{t-1}^{b,l}, z_{t-1}^{C,c,o}) \\ &= r_{z^C z^G}^{n',l} Cov(z_{t-1}^{G,b,l}, z_{t-1}^{C,c,o}) + r_{z^C z^C}^{n',l} Cov(z_{t-1}^{C,b,l}, z_{t-1}^{C,c,o}) + r_{z^C y}^{n',l} Cov(y_{t-1}^{b,l}, z_{t-1}^{C,c,o}) \end{aligned}$$

$$\begin{aligned} Cov(z_{t-1}^{C,a',n'}, y_{t-1}^{c,o}) &= Cov(r_{z^C z^G}^{n',l} z_{t-1}^{G,b,l} + r_{z^C z^C}^{n',l} z_{t-1}^{C,b,l} + r_{z^C y}^{n',l} y_{t-1}^{b,l}, y_{t-1}^{c,o}) \\ &= r_{z^C z^G}^{n',l} Cov(z_{t-1}^{G,b,l}, y_{t-1}^{c,o}) + r_{z^C z^C}^{n',l} Cov(z_{t-1}^{C,b,l}, y_{t-1}^{c,o}) + r_{z^C y}^{n',l} Cov(y_{t-1}^{b,l}, y_{t-1}^{c,o}) \end{aligned}$$

$$\begin{aligned} Cov(y_{t-1}^{a',n'}, z_{t-1}^{G,c,o}) &= Cov(r_{yz^G}^{n',l} z_{t-1}^{G,b,l} + r_{yz^C}^{n',l} z_{t-1}^{C,b,l} + r_{yy}^{n',l} y_{t-1}^{b,l}, z_{t-1}^{G,c,o}) \\ &= r_{yz^G}^{n',l} Cov(z_{t-1}^{G,b,l}, z_{t-1}^{G,c,o}) + r_{yz^C}^{n',l} Cov(z_{t-1}^{C,b,l}, z_{t-1}^{G,c,o}) + r_{yy}^{n',l} Cov(y_{t-1}^{b,l}, z_{t-1}^{G,c,o}) \end{aligned}$$

$$\begin{aligned}
Cov(y_{t-1}^{a',n'}, z_{t-1}^{C,c,o}) &= Cov(r_{yz^G}^{n',l} z_{t-1}^{G,b,l} + r_{yz^C}^{n',l} z_{t-1}^{C,b,l} + r_{yy}^{n',l} y_{t-1}^{b,l}, z_{t-1}^{C,c,o}) \\
&= r_{yz^G}^{n',l} Cov(z_{t-1}^{G,b,l}, z_{t-1}^{C,c,o}) + r_{yz^C}^{n',l} Cov(z_{t-1}^{C,b,l}, z_{t-1}^{C,c,o}) + r_{yy}^{n',l} Cov(y_{t-1}^{b,l}, z_{t-1}^{C,c,o})
\end{aligned}$$

$$\begin{aligned}
Cov(y_{t-1}^{a',n'}, y_{t-1}^{c,o}) &= Cov(r_{yz^G}^{n',l} z_{t-1}^{G,b,l} + r_{yz^C}^{n',l} z_{t-1}^{C,b,l} + r_{yy}^{n',l} y_{t-1}^{b,l}, y_{t-1}^{c,o}) \\
&= r_{yz^G}^{n',l} Cov(z_{t-1}^{G,b,l}, y_{t-1}^{c,o}) + r_{yz^C}^{n',l} Cov(z_{t-1}^{C,b,l}, y_{t-1}^{c,o}) + r_{yy}^{n',l} Cov(y_{t-1}^{b,l}, y_{t-1}^{c,o})
\end{aligned}$$

where b and c are siblings in law.

We can recursively compute the covariances for siblings in law, spouses of the sibling and siblings of the siblings of any degree.

Cousins in law $aa - cc$

We have to compute the covariances between "aa" and "cc". Let $n^* = m, f$ be the gender of aa and $o^* = m, f$ the gender of the cc . We project cc on c (his/her father or mother) who has gender o

$$\begin{aligned}
Cov(z_t^{G,aa,n^*}, z_t^{G,cc,o^*}) &= Cov(z_t^{G,aa,n^*}, G_{zgo}^{o^*} z_{t-1}^{G,b,o} + G_{zoo}^{o^*} z_{t-1}^{C,b,o} + G_{yoo}^{o^*} y_{t-1}^{b,o}) \\
&= G_{zgo}^{o^*} Cov(z_t^{G,aa,n^*}, z_{t-1}^{G,b,o}) + G_{zoo}^{o^*} Cov(z_t^{G,aa,n^*}, z_{t-1}^{C,b,o}) + G_{yoo}^{o^*} Cov(z_t^{G,aa,n^*}, y_{t-1}^{b,o})
\end{aligned}$$

$$\begin{aligned}
Cov(z_t^{G,aa,n^*}, z_t^{C,cc,o^*}) &= Cov(z_t^{G,aa,n^*}, C_{zgo}^{o^*} z_{t-1}^{G,b,o} + C_{zoo}^{o^*} z_{t-1}^{C,b,o} + C_{yoo}^{o^*} y_{t-1}^{b,o}) \\
&= C_{zgo}^{o^*} Cov(z_t^{G,aa,n^*}, z_{t-1}^{G,b,o}) + C_{zoo}^{o^*} Cov(z_t^{G,aa,n^*}, z_{t-1}^{C,b,o}) + C_{yoo}^{o^*} Cov(z_t^{G,aa,n^*}, y_{t-1}^{b,o})
\end{aligned}$$

$$\begin{aligned}
Cov(z_t^{G,aa,n^*}, y_t^{cc,o^*}) &= Cov(z_t^{G,aa,n^*}, B_{zgo}^{o^*} z_{t-1}^{G,b,o} + B_{zoo}^{o^*} z_{t-1}^{C,b,o} + B_{yoo}^{o^*} y_{t-1}^{b,o}) \\
&= B_{zgo}^{o^*} Cov(z_t^{G,aa,n^*}, z_{t-1}^{G,b,o}) + B_{zoo}^{o^*} Cov(z_t^{G,aa,n^*}, z_{t-1}^{C,b,o}) + B_{yoo}^{o^*} Cov(z_t^{G,aa,n^*}, y_{t-1}^{b,o})
\end{aligned}$$

$$\begin{aligned}
Cov(z_t^{C,aa,n^*}, z_t^{G,cc,o^*}) &= Cov(z_t^{C,aa,n^*}, G_{zgo}^{o^*} z_{t-1}^{G,b,o} + G_{zoo}^{o^*} z_{t-1}^{C,b,o} + G_{yoo}^{o^*} y_{t-1}^{b,o}) \\
&= G_{zgo}^{o^*} Cov(z_t^{C,aa,n^*}, z_{t-1}^{G,b,o}) + G_{zoo}^{o^*} Cov(z_t^{C,aa,n^*}, z_{t-1}^{C,b,o}) + G_{yoo}^{o^*} Cov(z_t^{C,aa,n^*}, y_{t-1}^{b,o})
\end{aligned}$$

$$\begin{aligned}
Cov(z_t^{C,aa,n^*}, z_t^{C,cc,o^*}) &= Cov(z_t^{C,aa,n^*}, C_{zgo}^{o^*} z_{t-1}^{G,b,o} + C_{zoo}^{o^*} z_{t-1}^{C,b,o} + C_{yoo}^{o^*} y_{t-1}^{b,o}) \\
&= C_{zgo}^{o^*} Cov(z_t^{C,aa,n^*}, z_{t-1}^{G,b,o}) + C_{zoo}^{o^*} Cov(z_t^{C,aa,n^*}, z_{t-1}^{C,b,o}) + C_{yoo}^{o^*} Cov(z_t^{C,aa,n^*}, y_{t-1}^{b,o})
\end{aligned}$$

$$\begin{aligned}
Cov(z_t^{C,aa,n^*}, y_t^{cc,o^*}) &= Cov(z_t^{C,aa,n^*}, B_{zgo}^{o^*} z_{t-1}^{G,b,o} + B_{zoo}^{o^*} z_{t-1}^{C,b,o} + B_{yoo}^{o^*} y_{t-1}^{b,o}) \\
&= B_{zgo}^{o^*} Cov(z_t^{C,aa,n^*}, z_{t-1}^{G,b,o}) + B_{zoo}^{o^*} Cov(z_t^{C,aa,n^*}, z_{t-1}^{C,b,o}) + B_{yoo}^{o^*} Cov(z_t^{C,aa,n^*}, y_{t-1}^{b,o})
\end{aligned}$$

$$\begin{aligned}
Cov(y_t^{aa,n^*}, z_t^{G,cc,o^*}) &= Cov(y_t^{aa,n^*}, G_{zgo}^{o^*} z_{t-1}^{G,b,o} + G_{zo}^{o^*} z_{t-1}^{C,b,o} + G_{yo}^{o^*} y_{t-1}^{b,o}) \\
&= G_{zgo}^{o^*} Cov(y_t^{aa,n^*}, z_{t-1}^{G,b,o}) + G_{zo}^{o^*} Cov(y_t^{aa,n^*}, z_{t-1}^{C,b,o}) + G_{yo}^{o^*} Cov(y_t^{aa,n^*}, y_{t-1}^{b,o})
\end{aligned}$$

$$\begin{aligned}
Cov(z_t^{G,aa,n^*}, z_t^{C,cc,o^*}) &= Cov(y_t^{aa,n^*}, C_{zgo}^{o^*} z_{t-1}^{G,b,o} + C_{zo}^{o^*} z_{t-1}^{C,b,o} + C_{yo}^{o^*} y_{t-1}^{b,o}) \\
&= C_{zgo}^{o^*} Cov(y_t^{aa,n^*}, z_{t-1}^{G,b,o}) + C_{zo}^{o^*} Cov(y_t^{aa,n^*}, z_{t-1}^{C,b,o}) + C_{yo}^{o^*} Cov(y_t^{aa,n^*}, y_{t-1}^{b,o})
\end{aligned}$$

$$\begin{aligned}
Cov(y_t^{aa,n^*}, y_t^{cc,o^*}) &= Cov(y_t^{aa,n^*}, B_{zgo}^{o^*} z_{t-1}^{G,b,o} + B_{zo}^{o^*} z_{t-1}^{C,b,o} + B_{yo}^{o^*} y_{t-1}^{b,o}) \\
&= B_{zgo}^{o^*} Cov(y_t^{aa,n^*}, z_{t-1}^{G,b,o}) + B_{zo}^{o^*} Cov(y_t^{aa,n^*}, z_{t-1}^{C,b,o}) + B_{yo}^{o^*} Cov(y_t^{aa,n^*}, y_{t-1}^{b,o})
\end{aligned}$$

where c is the sibling in law of the uncle/aunt of aa . We can recursively compute the covariances for cousins in law of any degree.